



PROGRAM  
FINANCED FROM  
THE NRDI FUND

Energy–Water–Food–Climate Nexus

*2025, Miskolc, Hungary*

## Book of Presentations

ENERGY WATER FOOD CLIMATE  
**NEXUS**<sup>®</sup>  
INTERNATIONAL SUMMIT



**AUGUST 26-28, 2025**  
**EUROPE**  
MISKOLC, HUNGARY

# Table of Contents

<b>Plenary Lectures</b> .....	<b>1</b>
Árpád B. Palotás: Introduction to the University of Miskolc and Its Activities .....	1
Victor Ibenausi et al. Data-Driven Optimization of Land Use Systems for Socio-Ecological Sustainability: Mississippi Major Land Resource Area.....	15
Fadong Li et al. Long-term Observation for Energy-Water-Food-Climate Nexus in China .....	21
Nokuthula Sibiyi: Advancing women-led pathways toward an Africa devoid of unemployment, hunger, climate risks, and inadequate human settlements: A scientific treatise.....	49
Klaus Maas and David Gilgen: The Graduate School NRW – Motivation of founding and initial experiences .....	55
Tamás Szolnoky: From Energy Industry to Agriculture: The Path of Lignite Toward Sustainability.....	64
Balázs Órfi: Water Management for the Sustainability .....	72
Péter Györkös: Waste management optimums – in reverse value chain engineering.....	87
Grisel Fierros Romero: Microbial Bioagents at the Water–Soil Nexus: Bioremediation Strategies for Sustainable Resource Management in Mexico .....	98
<b>Circular Economy</b> .....	<b>106</b>
Mbali Mkhize, Zama Sishi: Mobilising resources and partnerships for transdisciplinary impact: Strengthening the EWFCN at Historically Disadvantaged Institutions.....	106
Mandla Hlongwane: Reorienting innovation for inclusive economic growth in South Africa – Achieving the Sustainable Development Goal .....	115
Melvin Sello Mothoa: Green Entrepreneurship in the Circular Economy: Unlocking Opportunities for SMEs.....	122
Zita Szederkényi: Circularity in Business or Business in Circularity?.....	127
László Berényi: Personal issues about circularity: Approach to energy saving.....	143
Xolile Ngubane: The Role of Entrepreneurship in the Development of the Circular Economy in KwaZulu-Natal, South Africa .....	150
Ariyo Hidayanto: Synthesis & Screening Sodium Mordenite and Potassium Merlinoite Deposited Carbon [Na-MOR/C & K-MER/C] as Hydrogen Physisorbent .....	162

<b>Water Management</b> .....	<b>171</b>
Balázs Kovács: Freshwater Intrusion into Praid Salt Mine Future Possibilities.....	171
Thobeka Makhathini: Development of an Integrated Urban Water System to Mitigate Climate Change Impacts in Local Communities .....	188
Mohamed Hamdy Eid Hemida: Integrated Assessment of Groundwater Salinity Sources and Inter-Aquifer Mixing Dynamics in Siwa Oasis, Egypt.....	197
Sirine Trabelsi: Cement Kiln Dust use in Environmental Remediation: A Review of Applications ...	213
Tímea Miklós: Immobilization of TiO <sub>2</sub> /CNT Composites in PVDF Membranes for Oily Wastewater Treatment .....	221
Gyöngyvér Boglárka Nusser, Andrea Izbéki-Szabolcsik: The edibility of microgreens grown on greywater .....	232
<b>Energy</b> .....	<b>240</b>
Tamás Rittgasszer: Heat Conduction in a Rotating Body – Example of a Bicycle Disc Brake .....	240
Dinh Phi Truong: Recovery Potential of Noble Metals and Rare Earth Elements from Biomass Combustion Residues .....	250
Balázs Péter Kiss, George Kaptay, Zsolt Dobó: Investigation of Carbon Dioxide Conversion via Microwave Plasma .....	259
Ákos Bereczky et al Hydrogen Utilisation Potential and Experience in Conventional Thermal Power Plants.....	267
Dániel M. Papp: Hydrogen-assisted combustion in a lean premixed natural gas swirl burner .....	283
József Kádár: From Nexus Thinking to Action: Renewable Energy for Regional Cooperation and Climate Resilience.....	293
Gábor Nagy: Biogas Upgrading with Aquatic Plants.....	303
Salman Brbham: Improving Geothermal Heat Pump Efficiency by Testing Improved Soil Mixture..	319
<b>Climate, Waste and Agriculture</b> .....	<b>326</b>
Xolile Mkhize: Recent Food Innovations and Food Systems Transformation in South Africa .....	326
Busisiwe Nkonki-Mandleni: Co-design Circles as a Vehicle for Climate Change Adaptation .....	336
Adebayo S. Solanke, Michael Martínez-Colón: Spatial and Temporal Changes on the Fate and Bioavailability of Selenium – Is This Medical Geology? .....	348
Attila Havas: The Role of Foresight in Goal-Oriented Transformative Change Processes .....	357

Zsolt Dobó: Development of High-Resolution Particulate Matter Measurement Network in Miskolc and Kaposvár .....	370
Ljudmilla Bokányi et al. Innovative Approaches in Sewage Sludge Treatment Toward Soil Sustainability .....	382
Róbert Géber: Artificial Aggregates: An Alternative to Substitute Primary Raw Materials for Road Construction .....	390



**MISKOLCI EGYETEM**  
UNIVERSITY OF MISKOLC

**THE CAMPUS OF KNOWLEDGE AND COMMUNITY SPIRIT**

*Introduction to the University of Miskolc and its Activities*

*Prof. Árpád B Palotás*  
dean, Materials and Chemical Engineering



[uni-miskolc.hu](http://uni-miskolc.hu)



[unimiskolc](https://www.facebook.com/unimiskolc)



[miskolci\\_egyetem](https://www.instagram.com/miskolci_egyetem)



[@miskolci\\_egyetem](https://www.tiktok.com/@miskolci_egyetem)



[rektor@uni-miskolc.hu](mailto:rektor@uni-miskolc.hu)

2

**The campus of the University of Miskolc**



**MISKOLCI EGYETEM**  
UNIVERSITY OF MISKOLC

THE CAMPUS OF KNOWLEDGE AND COMMUNITY SPIRIT



[uni-miskolc.hu](http://uni-miskolc.hu)



[unimiskolc](https://www.facebook.com/unimiskolc)



[miskolci\\_egyetem](https://www.instagram.com/miskolci_egyetem)



[@miskolci\\_egyetem](https://www.tiktok.com/@miskolci_egyetem)



[rektor@uni-miskolc.hu](mailto:rektor@uni-miskolc.hu)



**3** **University traditions from 1762**

Founded in 1735 as a Bergschule  
Recognized as a „University” in  
1762 by Maria Theresia

**THE TIMETABLES™  
OF TECHNOLOGY**

A Chronology of the Most Important People  
and Events in the History of Technology

**First  
professor:  
Nikolaus  
Jacquin  
1763 -  
1769**





**PROFESSOR DOPPLER CHRISTIAN  
(1803 - 1853)**

**Famous professors,  
like:  
Christian Doppler  
1848 - 1850**

„Bergschule / Mining Academy”  
(School of Mining and Metallurgy)

1733 The Schemnitz Mining  
Academy (in Hungary) is  
the first technical college in  
the world; See also 1747 GEN Early in life



Living traditions on campus  
(included in the UNESCO World Heritage List)

 **MISKOLCI  
EGYETEM**  
UNIVERSITY OF MISKOLC

THE CAMPUS OF KNOWLEDGE AND COMMUNITY SPIRIT

 uni-miskolc.hu  unimiskolc  miskolci\_egyetem  @miskolci\_egyetem  rektor@uni-miskolc.hu



**4** **University of Miskolc – Today**

**Eight faculties**

- Earth and Environmental Sciences and Engineering (1762)
- Materials and Chemical Engineering (1762)
- Mechanical Engineering and Informatics (1949)
- Law (1981)
- Economics (1987)
- Humanities and Social Sciences (1992)
- Health Care Science (2005)
- Music (1997)



 **MISKOLCI  
EGYETEM**  
UNIVERSITY OF MISKOLC

THE CAMPUS OF KNOWLEDGE AND COMMUNITY SPIRIT

 uni-miskolc.hu  unimiskolc  miskolci\_egyetem  @miskolci\_egyetem  rektor@uni-miskolc.hu



**5 University of Miskolc in numbers**

- 3 Clubs
- 1 Canteen and several cafés
- 1 Main library and dozens of specialist libraries
- 85 Hectares
- 29 Buildings Educational buildings area: 135 000 square meters
- 35 Lecture halls
- cc. 500 International students from 70 countries all over the world
- 7 Dormitories with about 2 500 places
- 95 Classrooms
- cc. 11000 Students
- 1 Campus
- 630 Lecturers and researchers several research labs and workshops
- 59 Undergraduate programmes
- 8 Faculties
- 7 Doctoral Schools
- 76 Graduate programmes
- 1 Sport center with running tracks, tennis courts, gyms and sports fields
- Established in 1735

**MISKOLCI EGYETEM**  
UNIVERSITY OF MISKOLC

THE CAMPUS OF KNOWLEDGE AND COMMUNITY SPIRIT

uni-miskolc.hu | unimiskolc | miskolci\_egyetem | @miskolci\_egyetem | rektor@uni-miskolc.hu

**6 Industrial partners are involved in the (dual) education as well as in research programs**

**Large partner companies**

**The most important SME partners of the university**

**Regional Network of the University**

Regional Training Centres (Ózd, Sátoraljaújhely, Kazincbarcika)  
Regional Industrial Areas  
Local Governments of the Region

**MISKOLCI EGYETEM**  
UNIVERSITY OF MISKOLC

THE CAMPUS OF KNOWLEDGE AND COMMUNITY SPIRIT

uni-miskolc.hu | unimiskolc | miskolci\_egyetem | @miskolci\_egyetem | rektor@uni-miskolc.hu

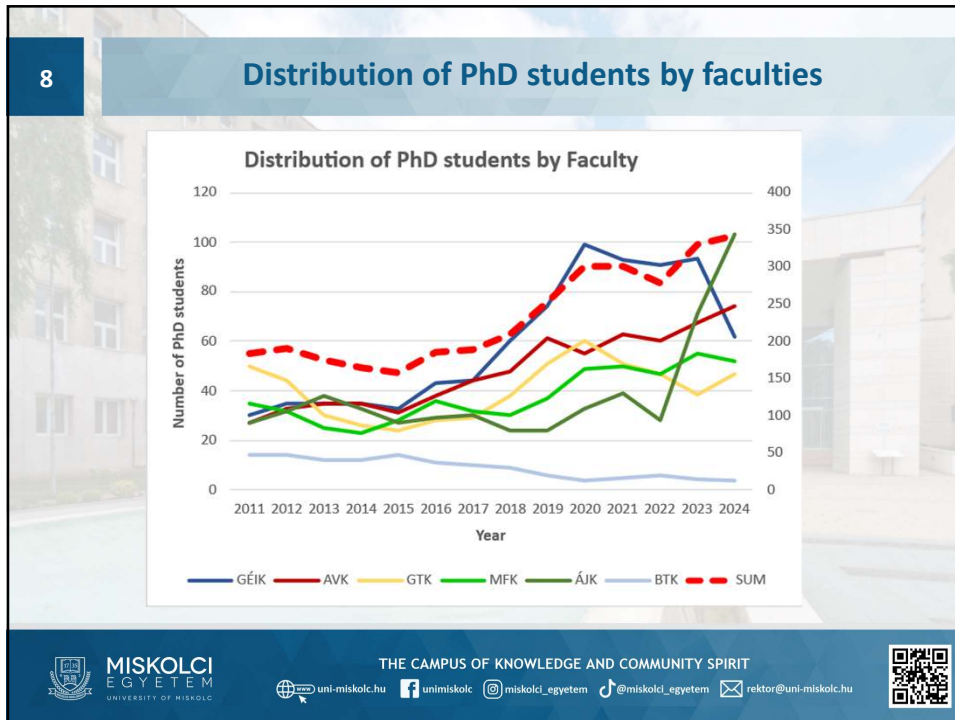
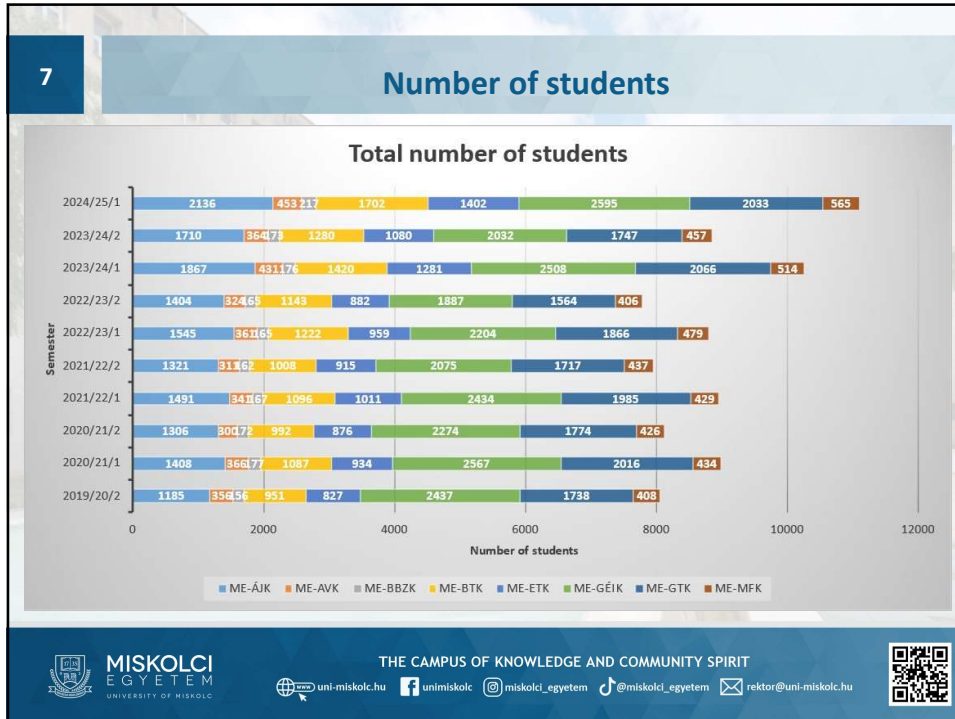

9

Students in dual training educational programs

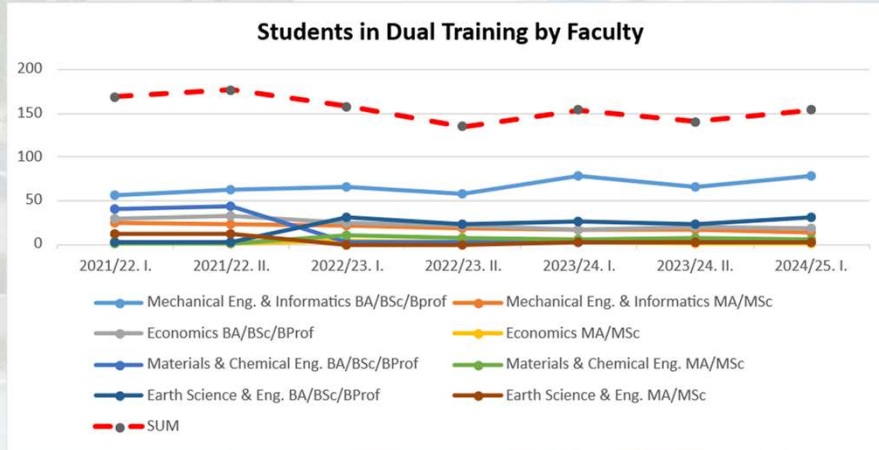

MISKOLCI EGYETEM  
UNIVERSITY OF MISKOLC



uni-miskolc.hu



unimiskolc



miskolci\_egyetem



@miskolci\_egyetem



rektor@uni-miskolc.hu



THE CAMPUS OF KNOWLEDGE AND COMMUNITY SPIRIT

10

Higher Education and Industry Collaboration Center

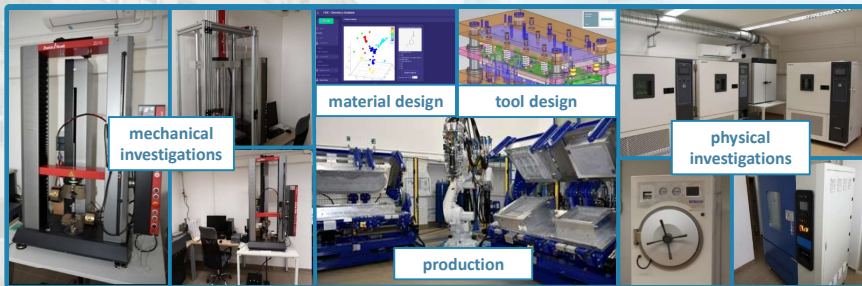

FROM MOLECULAR DESIGN TO A MARKETABLE PRODUCTS



MISKOLCI EGYETEM  
UNIVERSITY OF MISKOLC



uni-miskolc.hu



unimiskolc



miskolci\_egyetem



@miskolci\_egyetem



rektor@uni-miskolc.hu



THE CAMPUS OF KNOWLEDGE AND COMMUNITY SPIRIT

11

State of the art university infrastructure



- New lecture halls, seminar and meeting rooms
- New laboratories
- Spacious university buildings
- Well equipped departments
- High-scale workshop facilities
- Central and special libraries
- Network and fast Internet
- On-line databases
- Recreation and sports facilities



THE CAMPUS OF KNOWLEDGE AND COMMUNITY SPIRIT

uni-miskolc.hu | unimiskolc | miskolci\_egyetem | @miskolci\_egyetem | rektor@uni-miskolc.hu



12

Study programs for international students

Faculty	Study programmes	Undergraduate	Graduate	Doctoral (PHD)	Pre-university courses
Earth and Environmental Sciences and Engineering	Earth Sciences Engineering		●		
	Environmental Science Engineering		●		
	Hydrogeological Engineering		●		
	Petroleum Engineering		●		
	Petroleum Geoengineering		●		
	Earth Sciences			●	
Materials and Chemical Engineering	Materials Engineering	●	●		
	Space Engineering		●		
	Metallurgical Engineering		●		
	Material Sciences and Technologies			●	
Mechanical Engineering and Informatics	Computer Science Engineering	●	●		
	Mechanical Engineering	●	●		
	Logistics Engineering	●	●		
	Information Science and Technology			●	
	Mechanical Engineering Sciences			●	



THE CAMPUS OF KNOWLEDGE AND COMMUNITY SPIRIT





uni-miskolc.hu | unimiskolc | miskolci\_egyetem | @miskolci\_egyetem | rektor@uni-miskolc.hu



**13 Study programs for international students**

Faculty	Study programmes	Undergraduate	Graduate	Doctoral (PHD)	Pre-university courses
Law	European and International Business Law		•		
	Doctor of Law and Political Sciences			•	
Economics	Master of Business Administration (MBA)		•		
	Business and Management/ Regional Sciences			•	
	Business Administration and Management	•			
Humanities and Social Sciences	English and American Studies	•			
	Central European Studies		•		
	Cultural Anthropology		•		
	International Relations		•		
Health Sciences	Nursing and Patient Care	•			
Music	Performance	•			
	English Foundation Programme				•

**MISKOLCI EGYETEM**  
 UNIVERSITY OF MISKOLC

THE CAMPUS OF KNOWLEDGE AND COMMUNITY SPIRIT  
[uni-miskolc.hu](http://uni-miskolc.hu)
 [unimiskolc](https://www.facebook.com/unimiskolc)
 [miskolci\\_egyetem](https://www.instagram.com/miskolci_egyetem)
 [@miskolci\\_egyetem](https://www.tiktok.com/@miskolci_egyetem)
 [rektor@uni-miskolc.hu](mailto:rektor@uni-miskolc.hu)

**14 International cooperation on education**

**ERASMUS+, CEEPUS**

- Exchange programs
- Nomination by home university
- More than 400 English language courses

**Stipendium Hungaricum Program**  
**Christian Young People Program**

Full-degree scholarships with allowances

- 23 study programs
- More than 800 students in the past 7 years from more than 60 countries



**Double degree program – AMIR**  
**Study field: Innovative Recycling**

- University Bordeaux, France
- University of Liège, France
- TU Darmstadt, Germany
- University of Madrid, Spain
- NOVA University Lisbon, Portugal

**DOUBLE DEGREE PROGRAM – TIMREX**  
**Study field: Innovative Mineral Resource Innovation**

- University of Zagreb, Croatia
- Wroclaw University of Science and Technology, Poland
- Lulea University of Technology, Sweden

**MISKOLCI EGYETEM**  
 UNIVERSITY OF MISKOLC

THE CAMPUS OF KNOWLEDGE AND COMMUNITY SPIRIT  
[uni-miskolc.hu](http://uni-miskolc.hu)
 [unimiskolc](https://www.facebook.com/unimiskolc)
 [miskolci\\_egyetem](https://www.instagram.com/miskolci_egyetem)
 [@miskolci\\_egyetem](https://www.tiktok.com/@miskolci_egyetem)
 [rektor@uni-miskolc.hu](mailto:rektor@uni-miskolc.hu)

**15** **International cooperation on education**



**PANNÓNIA**  
Scholarship Programme

- The Hungarian Government's higher education scholarship programme for students and staff
- Mobilities based on Bilateral Agreements
- Long and short-term student mobility and excellence program



**PANNÓNIA** New outgoing international mobility programme from Hungary to any country in the world  
Scholarship Programme

 **HUF 350,000 – 400,000 monthly grants**

- » Study mobility
- » Traineeship mobility
- » Traineeship for recent graduates
- » Research mobility

- BA, MA, PhD, one-tier (5 years) program
- MA, PhD, one-tier (5 years) program





 **MISKOLCI EGYETEM**  
UNIVERSITY OF MISKOLC

THE CAMPUS OF KNOWLEDGE AND COMMUNITY SPIRIT

 uni-miskolc.hu  unimiskolc  miskolci\_egyetem  @miskolci\_egyetem  rektor@uni-miskolc.hu

**16** **Fee-paying international students**







- **25+ study programs available at all levels**
- **Tuition fees:**
  - Undergraduate: 2 400-3 000 EUR/semester
  - Graduate: between 3 500 EUR/semester
  - Doctoral: 3500 EUR/semester
- Language requirement: IELTS 6.0 or equivalent
- Application deadline for
  - Autumn: 15th of June
  - Spring: 15th of November



 **MISKOLCI EGYETEM**  
UNIVERSITY OF MISKOLC

THE CAMPUS OF KNOWLEDGE AND COMMUNITY SPIRIT

 uni-miskolc.hu  unimiskolc  miskolci\_egyetem  @miskolci\_egyetem  rektor@uni-miskolc.hu

**17** **Quality services and accommodation for the international students**

The infographic lists the following services and facilities:

- Sports hall
- Canteen
- Library
- Family-friendly room
- Dental office
- Mentor Systems
- Solarium
- 7 dormitories with about 2500 places
- Club
- Swimming pool
- Psychologist
- Wheelchair accessibility to buildings, dormitories, lifts and restrooms
- Mental Hygiene support
- Gym
- General practitioner (GP) office
- Post-office
- Supermarkets nearby
- Several cafeterias and buffets with cold and hot meals

**MISKOLCI EGYETEM**  
UNIVERSITY OF MISKOLC

THE CAMPUS OF KNOWLEDGE AND COMMUNITY SPIRIT

uni-miskolc.hu | unimiskolc | miskolci\_egyetem | @miskolci\_egyetem | rektor@uni-miskolc.hu

**18** **Success in the enrolment for the English language study programs at the University of Miskolc**

The chart displays enrolment numbers for the following programs:

- SH (1. semester)
- E+ (131+171 - 1. and 2. semesters)
- Double Degree - AMR (1. semester)
- CAE - ICCR Programme
- SCY (1. semester)
- Ceeplus (1. and 2. semesters)
- Double Degree - TIMREX (1. semester)
- CAE - HRRL Programme
- TFP (1. semester)
- Partial training (1. and 2. semesters)
- CAE - CECL Programme (PhD)

**Significant number of international students at the campus**

**MISKOLCI EGYETEM**  
UNIVERSITY OF MISKOLC

THE CAMPUS OF KNOWLEDGE AND COMMUNITY SPIRIT

uni-miskolc.hu | unimiskolc | miskolci\_egyetem | @miskolci\_egyetem | rektor@uni-miskolc.hu

**19 University of Miskolc on the world university ranking lists**

Year of result publication	QS	WUR	% (where we are)
JUNE 2025	QS 2026	1201-1400	TOP 70%

**QS TOP UNIVERSITIES**

Year of result publication	QS 2025	Subject: Eng – Mechanical, Aeronautical, and Manufact.
MARCH 2025	QS 2025	501-575

QS 2025 Engineering – Petroleum, 151-175

Year of result publication	THE	WUR
AUTUMN 2024	THE 2025	1501+

**THE Times Higher Education**

Year of result publication	RUR	Round University Ranking
May 2024	RUR 2024	738

**RUR ROUND UNIVERSITY RANKING**

**Ui GreenMetric World University Rankings**

1366 [University of Miskolc 2024](#)

**MISKOLCI EGYETEM UNIVERSITY OF MISKOLC**

THE CAMPUS OF KNOWLEDGE AND COMMUNITY SPIRIT

uni-miskolc.hu unimiskolc miskolci\_egyetem @miskolci\_egyetem rektor@uni-miskolc.hu

**20 UoM Science Park concept – 3 focus areas**

**Sustainable Resources**

**Logistics and Industrial Digitalization**

**Materials and Technologies**

**InnoME TTC 2025**

**MISKOLCI EGYETEM UNIVERSITY OF MISKOLC**

THE CAMPUS OF KNOWLEDGE AND COMMUNITY SPIRIT

uni-miskolc.hu unimiskolc miskolci\_egyetem @miskolci\_egyetem rektor@uni-miskolc.hu

**21** University infrastructure development – Green and Smart

Green and Smart Campus project

Central library and data analysis center

Dormitories



MISKOLCI EGYETEM UNIVERSITY OF MISKOLC

THE CAMPUS OF KNOWLEDGE AND COMMUNITY SPIRIT

[uni-miskolc.hu](http://uni-miskolc.hu) [unimiskolc](https://www.facebook.com/unimiskolc) [miskolci\\_egyetem](https://www.instagram.com/miskolci_egyetem) [@miskolci\\_egyetem](https://www.tiktok.com/@miskolci_egyetem) [rektor@uni-miskolc.hu](mailto:rektor@uni-miskolc.hu)



**22** Excellent sport infrastructure – EUG 2024

EUG

Tennis hall



MISKOLCI EGYETEM UNIVERSITY OF MISKOLC

THE CAMPUS OF KNOWLEDGE AND COMMUNITY SPIRIT

[uni-miskolc.hu](http://uni-miskolc.hu) [unimiskolc](https://www.facebook.com/unimiskolc) [miskolci\\_egyetem](https://www.instagram.com/miskolci_egyetem) [@miskolci\\_egyetem](https://www.tiktok.com/@miskolci_egyetem) [rektor@uni-miskolc.hu](mailto:rektor@uni-miskolc.hu)



23 **Why the University of Miskolc?**

**All-in-One, green and smart campus**   **Inclusive and diverse community**   **Good price - value ratio**   **Interdisciplinary approach**   **Collaborative research**

**MISKOLCI EGYETEM**  
UNIVERSITY OF MISKOLC

THE CAMPUS OF KNOWLEDGE AND COMMUNITY SPIRIT

uni-miskolc.hu   unimiskolc   miskolci\_egyetem   @miskolci\_egyetem   rektor@uni-miskolc.hu

24 **Mission (2025-2030)**

**“A campus of knowledge and community - for the future generation”**

**MISKOLCI EGYETEM**  
UNIVERSITY OF MISKOLC

THE CAMPUS OF KNOWLEDGE AND COMMUNITY SPIRIT

uni-miskolc.hu   unimiskolc   miskolci\_egyetem   @miskolci\_egyetem   rektor@uni-miskolc.hu

**25** **The EWFCN 2025 team (Hungary)**

**Finances**

- István Nagy
- Boglárka Bencsik
- Barbara Lassúné Kozma

**Technical staff**

- Zoltán Sajti
- Zoltán Ongai

**Excursion and office**

- Emese Sebe
- Csenge Emese Tóth
- Balázs Hegedűs

**Registration and administration**

- Emese Mesterné Kurovics
- Bettina Erdélyi-Rajhárd
- Éva Nagy-Kócsák



**AUGUST 26-28, 2025  
EUROPE  
MISKOLC, HUNGARY**

**Program Committee**

- Csaba Deák
- Tamás Madarász
- Árpád B. Palotás

**“We will solve any problem”**

**▪ Zsolt Veres**

**Session Chairs**

- Csaba Deák
- Helga Kovács
- Balázs Kovács
- Klaus Maas
- Sándor Nagy

**Dormitory and Catering**

- Virág Tóth
- László Sulák
- Rebeka Szabó

**Transportation**

- István Ilyó-Kovács

**Website**

- Richárd Nemes



**MISKOLCI EGYETEM**  
UNIVERSITY OF MISKOLC

THE CAMPUS OF KNOWLEDGE AND COMMUNITY SPIRIT

[uni-miskolc.hu](http://uni-miskolc.hu)
[unimiskolc](https://www.facebook.com/unimiskolc)
[miskolci\\_egyetem](https://www.instagram.com/miskolci_egyetem)
[@miskolci\\_egyetem](https://www.tiktok.com/@miskolci_egyetem)
[rektor@uni-miskolc.hu](mailto:rektor@uni-miskolc.hu)



**26** **The EWFCN 2025 team**



**AUGUST 26-28, 2025  
EUROPE  
MISKOLC, HUNGARY**

Thank you for visiting us and  
have a safe flight home!



**MISKOLCI EGYETEM**  
UNIVERSITY OF MISKOLC

THE CAMPUS OF KNOWLEDGE AND COMMUNITY SPIRIT

[uni-miskolc.hu](http://uni-miskolc.hu)
[unimiskolc](https://www.facebook.com/unimiskolc)
[miskolci\\_egyetem](https://www.instagram.com/miskolci_egyetem)
[@miskolci\\_egyetem](https://www.tiktok.com/@miskolci_egyetem)
[rektor@uni-miskolc.hu](mailto:rektor@uni-miskolc.hu)



27

Tradition and Innovation



MISKOLCI  
EGYETEM  
UNIVERSITY OF MISKOLC



[uni-miskolc.hu](http://uni-miskolc.hu)



[unimiskolc](https://www.facebook.com/unimiskolc)



[miskolci\\_egyetem](https://www.instagram.com/miskolci_egyetem)



[@miskolci\\_egyetem](https://www.tiktok.com/@miskolci_egyetem)



[rektor@uni-miskolc.hu](mailto:rektor@uni-miskolc.hu)





## Data-Driven Optimization of Land Use Systems for Socio-Ecological Sustainability: Mississippi Major Land Resource Area (MLRA)

Dr. Victor Ibeanusi, Dr. Gang Chen, Dr. Hubert Hirwa, Ph.D....  
School of the Environment  
Florida A&M University

## Background

- Over-extraction has led to significant groundwater level declines and streamflow.
- Warming temperatures, more extreme precipitation, rising sea levels, and intensified storms.
- Substantial coastal and deltaic land loss.
- Flooding & Disaster Vulnerability

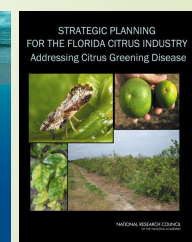
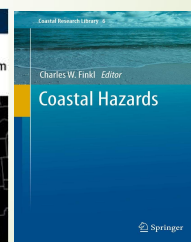
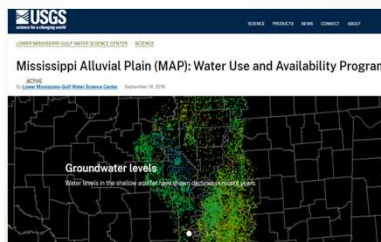
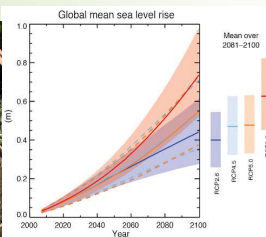

# Datasets

- Climate data



<https://prism.oregonstate.edu/normals/>

- Crop Layer data



<https://croplandcros.scinet.usda.gov/>

- Digital Elevation Model (DEM)

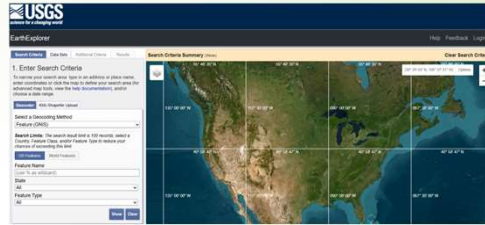

- Soil data



<https://websoilsurvey.sc.egov.usda.gov/App/HomePage.htm>



<https://www.fao.org/soils-portal/data-hub/soil-maps-and-databases/faunesco-soil-map-of-the-world/en/ov/>

# Datasets

- Crop management operation data

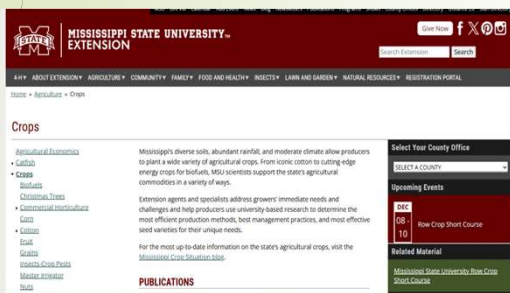

- Land Use and Land Cover

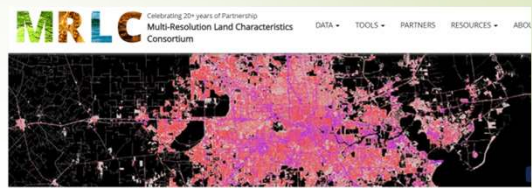

Multi-Resolution Land Characteristics (MRLC) Consortium



<https://www.mrlc.gov/>

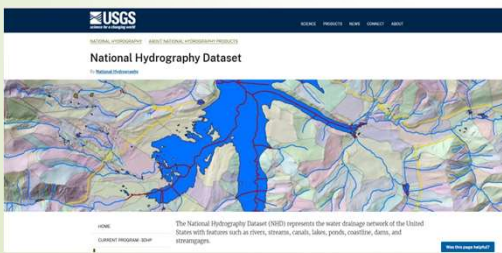

## How do we use the Big Data?

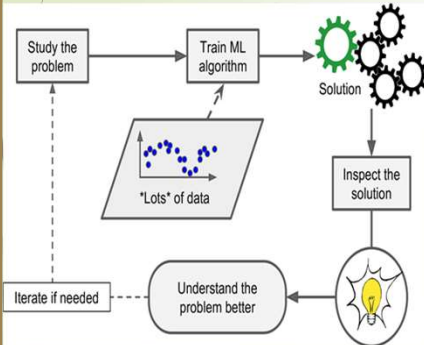

Source: [The Machine Learning Landscape \[Book\]](#)

### Machine Learning



### IoT and Big Data



### Deep learning

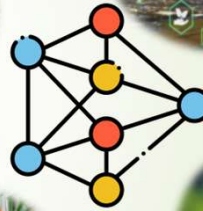

### Robots



## Interpolation-based Spatio-temporal Analysis

- Study Area: **Hickahala Watershed (HW)**

- HW spans approximately **146,190 acres**.

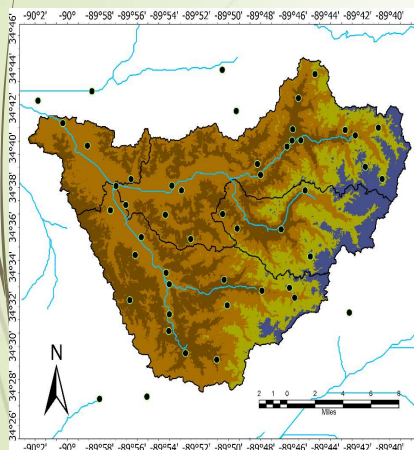

Map of Hickahala Creek Watershed with the location of the stations

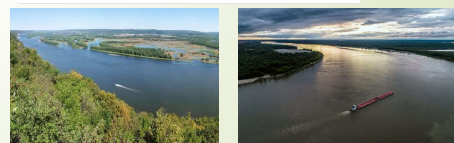
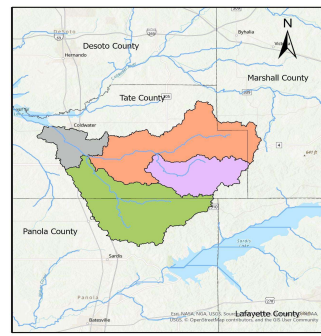
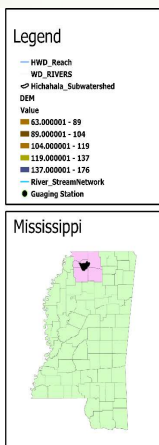

Mississippi River. Source: Britannica and American Rivers

## Interpolation-based Spatio-temporal Analysis

### Kriging Method

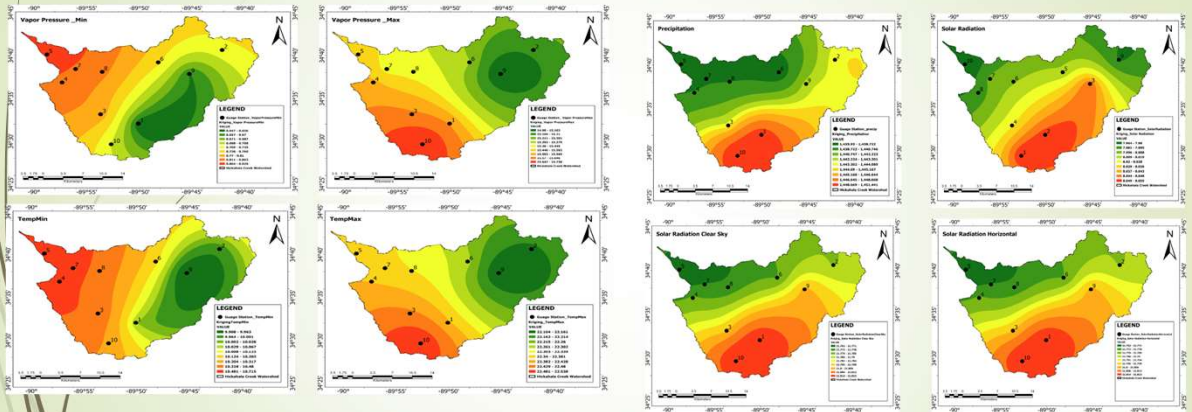

**Climatic variables:** Vapor Pressure\_Min, Vapor Pressure\_Max, Temperature\_Min, Temperature\_Max, Precipitation, Solar Radiation, Solar Radiation Clear Sky and Solar Radiation Horizontal

## Many innovations and technologies are on the horizon!

### Agricultural innovations to a Sustainable Resource Nexus

- Enhancing resilience through agroecology, precision farming, and regenerative agriculture.
- Promoting stress-resistant crops to cope with drought, heat, hail, pests, etc.
- Integrated Water/Pest Management
- Recycling waste for fertilizer/feeds

Photo credits

[Pacific Biochar](#)  
[Hubert Hirwa](#)  
[AZO Life Sciences](#)  
[FarmProgress](#)



## A Prospective Funding Opportunity

- [ClimateWorks Foundation](#), with the support of a coalition of global foundations, including [Howden Foundation](#), [Laudes Foundation](#), [Quadrature Climate Foundation](#), and [The Rockefeller Foundation](#), has launched a \$50 million dollar Adaptation and Resilience Fund (A&R Fund) to support locally led efforts that reduce climate risk and strengthen community well-being. The fund is interested in deploying capital to support projects such as early warning systems and innovative finance tools.
- Two new Request for Proposals were released to address extreme heat in urban areas across South Asia, Southeast Asia and Sub-Saharan Africa.
- Total initial funding available: \$9 million
- Deadline: September 19, 2025
- RFP 1: Innovative Finance for Urban Resilience - [More about the application process](#)
- RFP 2: Strengthening Institutions and Civil Society – [More about the application process](#)

## Funding Initiative from Google.org

- In the Spring of 2025, Google.org announced funding and support for the first two focus areas under its AI Collaboratives Initiative.

WILDFIRES	FOOD SECURITY
<p>With \$27 million in support provided to date, the <b>AI Collaborative: Wildfires</b> is a strategic initiative by Google.org bringing together leading nonprofits, academic institutions, government agencies and companies to help people and communities better manage fires by providing the tools they need to <a href="#">identify and track wildfires</a> in near real time; quantify wildfire risk; shift more acreage to beneficial fires; and ultimately reduce the damage caused by catastrophic wildfires.</p>	<p>With commitments of \$25 million in support, the <b>AI Collaborative: Food Security</b> will strengthen the resilience of global food systems and improve food security for the world's most vulnerable populations through AI technologies, collaborative research, data-sharing and coordinated action. These technologies will be leveraged to enhance hunger forecasting, strengthen crop resilience, and bolster smallholder farmers.</p>

## Conclusion

### We can advance sustainable and resilient land use systems through the Geospatial Artificial Intelligence (AI)/Machine Learning

- Requires integrated system approach and renewed commitment to innovation, in both technologies and institutions/policies
- Strengthening Resource Nexus by enhancing **EnergyWaterFoodClimateNexus (EWFN)** planning and promoting circular economy principles in every sector.
- Use machine learning and AI to enhance predictive capabilities, enabling efficient resource allocation, climate adaptation strategies, and early warning systems for resources at risk.
- Enhanced risk management and social protection serve as essential catalysts for innovation and progress.

## Q+A



ENERGY WATER FOOD CLIMATE  
**NEXUS**  
INTERNATIONAL SUMMIT

AUGUST 26-28, 2025  
EUROPE  
MISKOLC, HUNGARY

中国科学院大学  
University of Chinese Academy of Sciences

# Long-term Observation for Energy-Water-Food-Climate Nexus in China

Fadong Li, Zhaoxin Li, Ning Wang, Ning Xu et al.  
Shandong Yucheng Agro-ecosystem National Observation and Research Station  
Institute of Geographic Sciences and Natural Resources Research, Chinese Academy of Sciences  
University of Chinese Academy of Sciences  
Aug., 2025, Miskolc, Hungary

中国科学院大学  
University of Chinese Academy of Sciences

- 1 Research Significance
- 2 Global Research Hotspots
- 3 Main research methods

OUTLINES



**1** Research Significance

**2** Global Research Hotspots

**3** Main research methods

OUTLINES

## Why the EWFC Nexus Matters ?



**From EWFC itself:**

- ◆ **Water** is needed for 90 % of global power generation,
- ◆ **energy** is required to treat & move **water**
- ◆ both support **food** production
- ◆ all three sectors are being reshaped by a **changing climate**

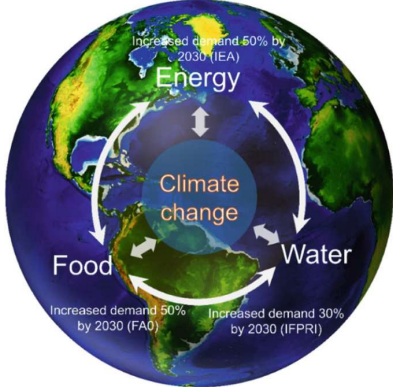

Dang, N.M. et al. (2022). Water–Food–Energy Nexus in the Context of Climate Change: Developing a Water Security Index for Water Resource Management in Vietnam. [https://doi.org/10.1007/978-3-030-81443-4\\_39](https://doi.org/10.1007/978-3-030-81443-4_39)

**EWFC is therefore a**  
**Mutually-reinforcing systems**

# Why the EWFC Nexus Matters ?



From world development:

◆ **Central to the SDGs & Paris goals:** Integrated management of the nexus underpins at least ten Sustainable Development Goals (2, 6, 7, 12, 13 ...) and every credible pathway to net-zero.



Water, Food and Energy. UN Water. [https://www.unwater.org/water-facts/water-food-and-energy?utm\\_source=chatgpt.com](https://www.unwater.org/water-facts/water-food-and-energy?utm_source=chatgpt.com)

# Why the EWFC Nexus Matters ?



From world development:

◆ **Economic exposure is rising:**  
 Since 2022, heatwaves, floods and droughts have driven double-digit spikes in staple-food prices on four continents, illustrating how climate extremes propagate across nexus sectors and into inflation.

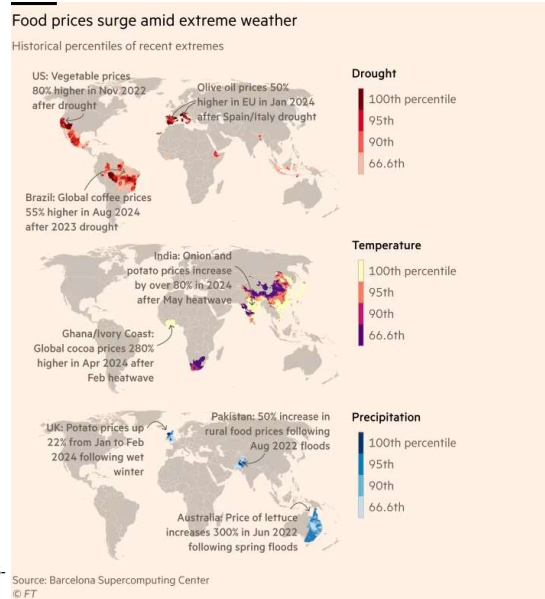

How we made it: how extreme weather is driving food prices . Financial Times. <https://www.ft.com/content/3e6fd135-9fac-4238-8675-614229f5d0b9>

## Societal & Scientific Pay-offs



- ◆ **Early-warning & adaptive management:** Integrated observatories feed real-time decision-support dashboards for drought relief, flood control, and energy-grid balancing
- ◆ **Transdisciplinary discovery:** Future Earth' s Nexus Knowledge-Action Network and Critical-Zone Observatories show how co-located social, ecological and biophysical measurements unlock new insights into coupled human-natural systems.
- ◆ **Global public goods:** Open data platforms (GEWEX, WaPOR, Copernicus, WMO Integrated Global Observing System) democratise access to high-resolution EWFC information, accelerating research in the Global South.



OUTLINES



1 Research Significance

2 Global Research Hotspots

3 Main research methods

## Global Research Hotspots



### ◆ Crop Water-Use Efficiency (WUE) monitoring

Examines how water productivity of crops has changed over decades using satellite data and field sensors. Helps us understand where irrigation is most and least effective and guides improvements in water management.

### ◆ Key conclusions

1. Revealed gaps in efficiency gains across different regions, pointing to where irrigation needs modernizing.
2. Showed that inconsistent data processing can skew results, so common protocols are essential.

Jiang, M. et al. A 20-year dataset (2001–2020) of global cropland water-use efficiency at 1-km grid resolution. *Sci Data* 12, 574 (2025) | <https://doi.org/10.1038/s41597-025-01606-1>

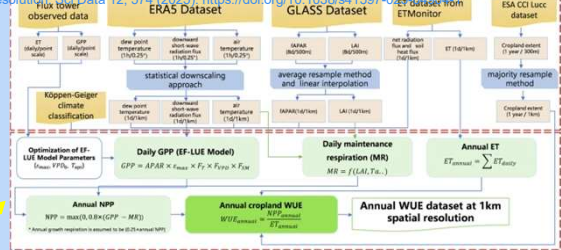

Kariminda, A. R. et al. The role of time averaging of eddy covariance fluxes on water use efficiency dynamics of maize. *Atmos. Meas. Tech.* 17, 5477–5490. <https://doi.org/10.5194/amt-17-5477-2024>

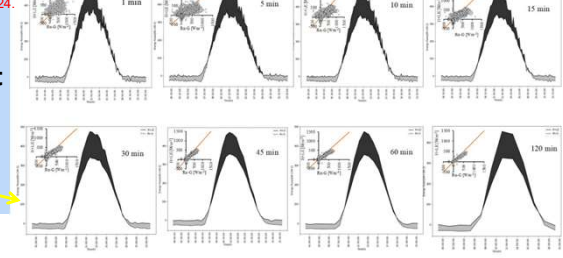

## Global Research Hotspots



### ◆ Renewable-Powered Irrigation & Agrivoltaics

Looks at combining solar energy with irrigation and crop production—either by powering pumps with PV panels or co-locating panels above fields. It explores how clean energy can improve water access and farm resilience.

### ◆ Key conclusions

1. Demonstrated that solar-powered pumps can expand irrigation without adding fossil-fuel use, if groundwater is managed.
2. Found that agrivoltaic setups balance small yield changes with gains in water and income stability.

Stid, J. T. et al. Impacts of agrisolar co-location on the food–energy–water nexus and economic security. *Nat Sustain* 8, 702–713 (2025). <https://doi.org/10.1038/s41893-025-01546-4>

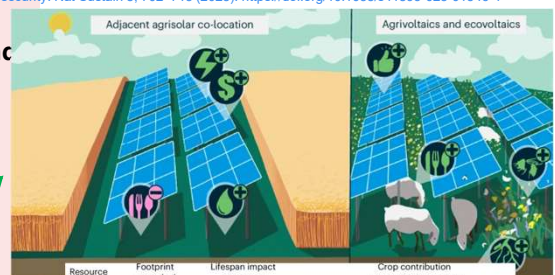

Resource	Footprint units/ha/yr	Lifespan impact base (range)	Crop contribution proportion of lifespan impact
Land	—	3.62 k ha (4.40   4.33)	
Food	-15.6 M kcal -21.2 M kcal	-1.41 T kcal (-1.81, -1.09) -0.16 T kcal (-0.21, -0.13)	
Energy	1.26 G Wh 1.30 G Wh	114 T Wh (102, 142) 10.0 T Wh (8.93, 12.3)	
Water	6.02 k m <sup>3</sup> 5.46 k m <sup>3</sup>	544 M m <sup>3</sup> (438, 650) 42.1 M m <sup>3</sup> (32.4, 51.8)	
Economic	2.69 k US\$ 124 k US\$	243 M US\$ (-39.1, 531) 959 M US\$ (641, 1,380)	

Legend: Grain, Hay/pasture, Cotton, Orchards, Grapes, Vegetables, Other crops

et al. (2023). Solar irrigation in sub-Saharan Africa: economic feasibility and development potential.

## Global Research Hotspots

### ◆ Nitrogen Management as a Nexus Lever

Focuses on how precise use of nitrogen fertilizer affects crop yields, water quality, energy use, and greenhouse-gas emissions. Long-term trials and models show the wider benefits of better N application.

### ◆ Key conclusions

1. Showed that fine-tuned N use can cut over-application, reducing water pollution and energy spent on fertiliser production.
2. Highlighted social and economic benefits, making a case for investment in precision-N tools.

Chen, B. et al. Managing nitrogen to achieve sustainable food-energy-water nexus in China. Nat Commun 16, 4804 (2025). <https://doi.org/10.1038/s41467-025-66398-5>

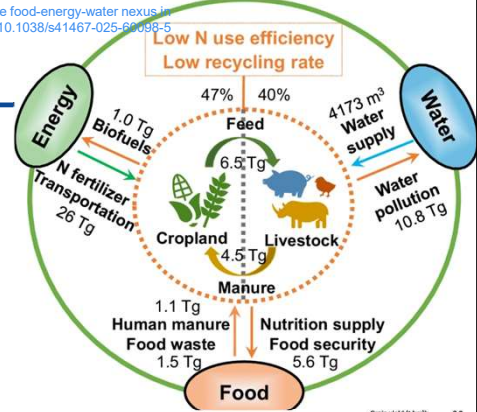

Chmellková, L. et al. Energy-use efficiency of organic and conventional plant production systems in Germany. Sci Rep 14, 1806 (2024). <https://doi.org/10.1038/s41598-024-51768-3>

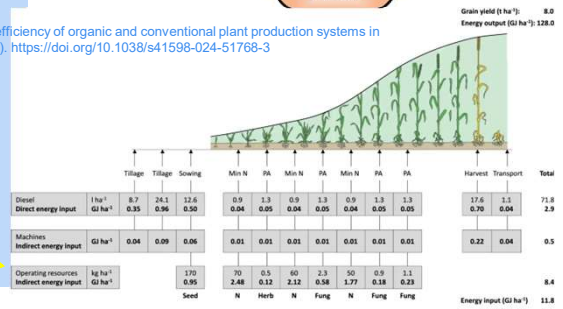

## Global Research Hotspots

### ◆ Critical-Zone & Flux-Tower Networks

Long-running observatories measure exchanges of water, energy, and carbon between the land surface and atmosphere. They reveal how soils, plants, and groundwater respond to climate and management.

### ◆ Key conclusions

1. Identified rising evapotranspiration trends under warming, warning of future water stress. (Barr A. et al., Earth System Science Data (2025) preprint, DOI 10.5194/essd-2024-492.)
2. Revealed hidden water losses to shallow groundwater that offset surface-water savings.

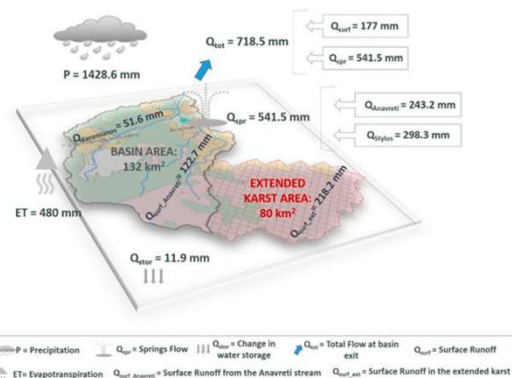

Lilli, M.A. et al. A Multi-Disciplinary Approach to Understand Hydrologic and Geochemical Processes at Kollaris Critical Zone Observatory. Water 2020, 12, 2474. <https://doi.org/10.3390/w12092474>

## Global Research Hotspots



### ◆ Systems-Level Modelling & Multi-Objective Optimization

develops integrated computer models that balance water, energy, and food goals. By simulating different strategies, it pinpoints interventions that deliver overall gains rather than shifting trade-offs.

### ◆ Key conclusions

1. Demonstrated that joint planning reduces combined resource shortages compared to siloed approaches. (Okola I. et al., Earth's Future (2025), DOI 10.1029/2024EF004718.)
2. Showed that some well-intentioned fixes (e.g., desalination) can undermine food security if not linked with

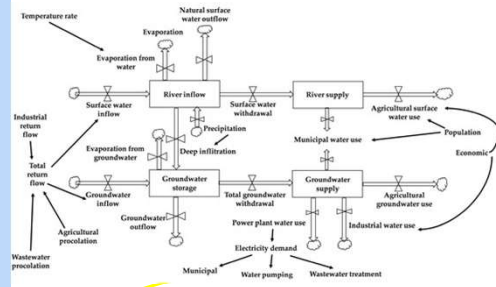

Javan, K. et al. Assessing the Water-Energy-Food Nexus and Resource Sustainability in the Ardebil Plain: A System Dynamics and HWA Approach. *Water* 2023, 15, 3673. <https://doi.org/10.3390/w15203673>

## Global Research Hotspots



### ◆ Behaviour, Policy & Governance

Studies in this area explore how farmer choices, policies, and incentives shape adoption of nexus-friendly practices. Long-term surveys and experiments reveal the social drivers of sustainable resource use.

Olha H. et al. Are farmers willing to adopt climate-smart Water-Energy-Food-Environment Nexus designs? A case of olive producers in Crete using a participatory choice experiment. *Environmental Impact Assessment Review*, 2025, <https://doi.org/10.1016/j.eiar.2025.108048>.

### ◆ Key conclusions

1. Found that securing water rights and reducing risk matter more to farmers than just cutting energy costs.
2. Warned that policies focusing only on carbon can unintentionally harm water or biodiversity without a holistic nexus view. (IPBES, Nexus Assessment Report (2024), ISBN 978-3-96056-069-5.)

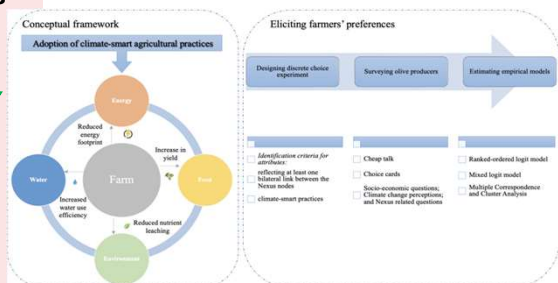





**1** Research Significance

**2** Global Research Hotspots

**3** Main research methods

OUTLINES



## Main research methods

◆ **Field Observatories (Flux Towers & Critical-Zone Sites)**

Networks of eddy-covariance towers and soil-groundwater plots track water, energy and carbon at farm to basin scale for decades, giving ground-truth for all other studies.

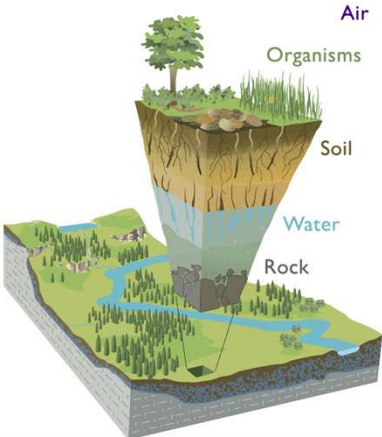

- Long records reveal gradual shifts in evapotranspiration and carbon exchange, guiding irrigation and land-use policy.
- Site data calibrate and validate coupled crop-hydro models, cutting simulation error and improving future projections.

## Main research methods



### Remote Sensing & Geospatial Products

Satellites (MODIS, Sentinel, Landsat) and open portals such as FAO-WaPOR supply consistent, multi-decadal maps of crop water use, vegetation stress and groundwater

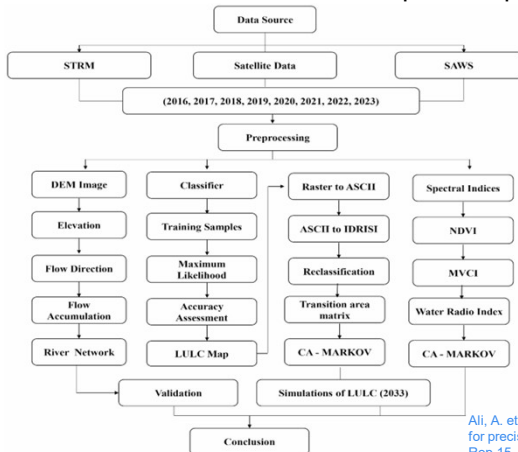

- Remote data close monitoring gaps in data-poor regions and allow global comparisons of irrigation performance.
- New high-resolution sensors and fusion techniques sharpen field-scale estimates of soil moisture and crop stress for management decisions.

#### An example of the satellite method research framework

Ali, A. et al. Advanced satellite-based remote sensing and data analytics for precision water resource management and agricultural optimization. *Sci Rep* 15, 27527 (2025). <https://doi.org/10.1038/s41598-025-13167-0>

## Main research methods



### Coupled Hydro-Agro-Energy Simulation Models

Process-based models (e.g., SWAT+, WEAP, AquaCrop) link weather, hydrology, crops and energy demand to test long-term scenarios for water, food and climate security.

EPIC	The Water, Energy, Food Nexus Tool		
SWAT	MuSIASEM	DSSAT	MARKAL
SWAP Model	CropSyst	ANEMI	
WEAP	Q-Nexus Model	WEF Nexus Index	

Most-used Nexus Tools

- Integrated frameworks capture cross-sector feedbacks that single-sector models miss, exposing hidden trade-offs.
- New “natural–social” simulators reproduce household water, energy and food flows, improving policy relevance in water-scarce basins.

# Main research methods

## ◆ Multi-Objective Optimisation & Scenario Tools

Evolutionary algorithms (e.g., NSGA-II) and scenario planners search for strategies that balance water, energy and food goals instead of maximising one at others' expense.

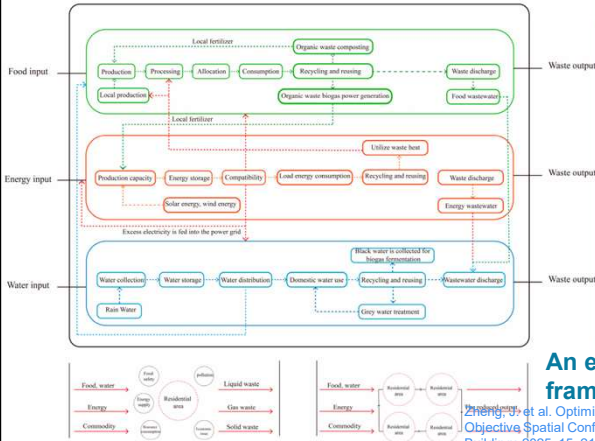

- Integrated optimisation cuts combined scarcity risks compared with siloed planning, revealing true “win-win” frontiers.
- Urban and basin case studies show that designs such as rooftop agrivoltaics or desal-plus-demand-management only succeed when analysed as

An example of multi-objective optimisation framework

Zheng, Y. et al. Optimizing the Food–Energy–Water Nexus: A Multi-Objective Spatial Configuration Framework for High-Density Communities. *Buildings* 2025, 15, 2196. <https://doi.org/10.3390/buildings15132196>

# Main research methods

## ◆ Socio-Economic Longitudinal Surveys & Experiments

Household panels, farmer choice experiments and participatory games track how people adopt (or reject) nexus-smart practices over time

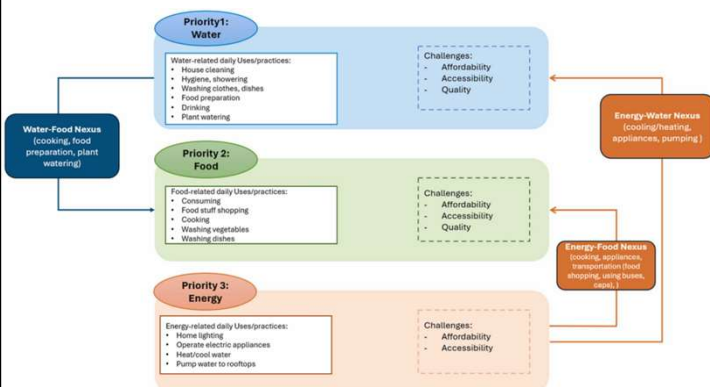

Household water–energy–food nexus conceptual framework.

Al-Zu'bi M. et al., *Journal of Cleaner Production*, 2025.

- Consumption diaries uncover daily WEF links inside homes, informing demand-side policies.
- Experiments show that secure water rights and risk buffering outweigh energy savings in motivating farmers, guiding subsidy design.

# Main research methods



## ◆ AI & Big-Data Fusion

Machine-learning and deep-learning models merge satellite, sensor and climate data to predict crop water use, drought risk and system feedbacks in near-real time.

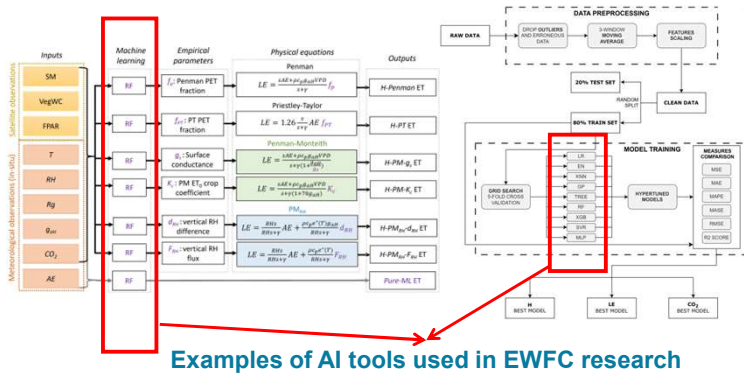

- ML boosts flux and evapotranspiration estimates, especially where ground stations are sparse.
- Hybrid “physics-guided” networks outperform pure data-driven models, showing the value of domain knowledge.

Examples of AI tools used in EWFC research

García-Rodríguez D. et al., Agricultural and Forest Meteorology, 2024, DOI 10.1016/j.agrformet.2024.109506. Kim Y. et al., PLOS ONE, 2025, DOI 10.1371/journal.pone.0328798.

ENERGY WATER FOOD CLIMATE  
**NEXUS**  
INTERNATIONAL SUMMIT

AUGUST 26-28, 2025  
EUROPE  
MISKOLC, HUNGARY

中国科学院大学  
UNIVERSITY OF CHINESE ACADEMY OF SCIENCES

# Long-term Observation for Energy-Water-Food-Climate Nexus in China

## CASE Study



OUTLINES

  **中国科学院大学**  
University of Chinese Academy of Sciences

- 1 Background and Significance**
- 2 CERN and Yucheng Station**
- 3 Main Findings**



OUTLINES

  **中国科学院大学**  
University of Chinese Academy of Sciences

- 1 Background and Significance**
- 2 CERN and Yucheng Station**
- 3 Main Findings**

# Global Resource and Climate Challenges

Growing global pressure on energy, water, food, and climate systems



Key Drivers



Renewable water resources distribution

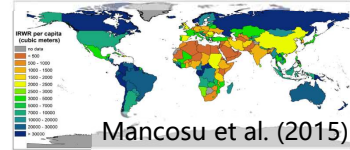

## What Is the EWFC Nexus?



### Energy–Water–Food–Climate (EWFC) Nexus

- Interdependent Systems
- Mutual Resource Flows
- Climate as Overlay
- Synergies & Trade-offs
- Why It Matters

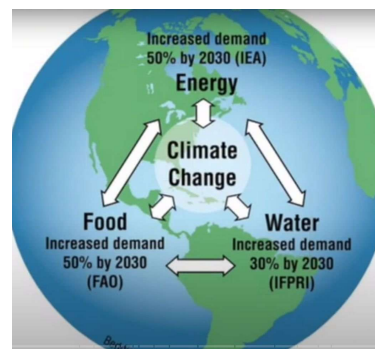

<https://www.globalclimatechangeweek.net/the-food-water-energy-nexus-in-climate-change>

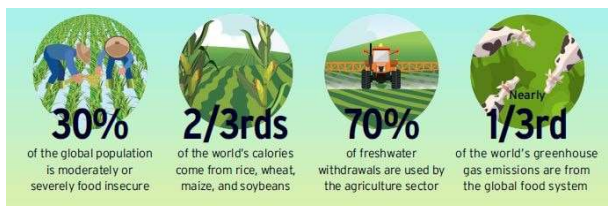

## Why Long-term Observation?



### Importance of Long-term Observation

- ◆ **Reveal Interactions:** Uncover dynamic links among energy, water, food, and climate.
- ◆ **Baseline & Trends:** Track long-term changes, risks, and thresholds.
- ◆ **Support Decisions:** Provide reliable data for sustainable resource management and climate adaptation.
- ◆ **Innovation Platform:** Enable open science, data integration, and cross-sector solutions.

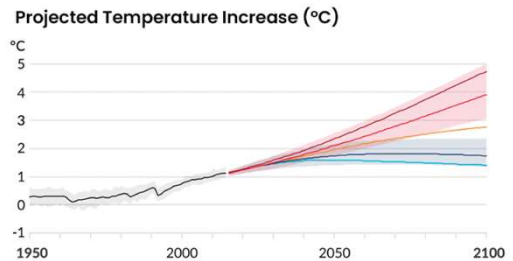

Five Scenarios of Fossil Fuel Burning

- Highest CO<sub>2</sub> amounts
- Medium to high CO<sub>2</sub> amounts
- Medium CO<sub>2</sub> amounts
- Smaller CO<sub>2</sub> amounts, then no increase in CO<sub>2</sub> late in the 21st century
- No increase in CO<sub>2</sub>, beginning in 2050

<https://climateknowledgeportal.worldbank.org/overview>

## Key Elements of Long-term Observation

### What to Observe and How?

- ◆ **Multi-Scale Networks:** Field stations, remote sensing, and big data platforms.
- ◆ **Integrated Indicators:** Water fluxes, energy use, food production, and GHG emissions.
- ◆ **Cross-Regional Focus:** From local ecosystems to national and global perspectives.
- ◆ **Data Sharing:** Open-access data for collaborative research and policy support.
- ◆ **Capacity Building:** Train new-generation researchers and leaders.

### Multivariate data collection

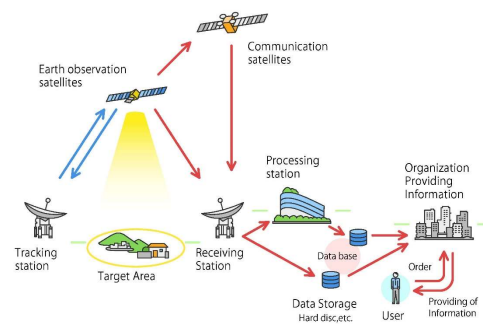

<https://www.restec.or.jp/en/knowledge/sensing/sensing-4.html>

# Current Status of EWFC in China



## EWFC Nexus in China: Current Landscape

- ◆ **High Resource Demand:** World's largest consumer of energy and water for agriculture and industry.
- ◆ **Rapid Urbanization:** Rising pressure on food supply, energy security, and ecosystems.
- ◆ **Climate Sensitivity:** Agriculture and water resources highly vulnerable to climate variability.
- ◆ **Policy Frameworks:** Steps toward carbon neutrality and food security strategies.



<https://www.newsecuritybeat.org/2015/05/illustrating-chinas-water-energy-food-choke-points-infographics/>

# Key Challenges



## Challenges Facing China's EWFC Nexus

- ◆ **Water Scarcity:** North China Plain and arid regions face severe water deficits.
- ◆ **Energy-Water Conflicts:** Thermal power plants and agriculture compete for water resources.
- ◆ **Food Security Risks:** Land degradation, fertilizer overuse, and climate extremes.
- ◆ **Carbon Emissions:** High GHG emissions from energy and agricultural sectors.

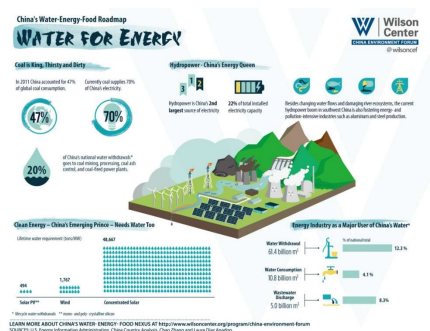

<https://www.newsecuritybeat.org/2015/05/illustrating-chinas-water-energy-food-choke-points-infographics/>

# Opportunities and Strategies



## Opportunities for Integrated Solutions

**Green Energy Transition:** Renewable energy and water-efficient technologies.

**Smart Agriculture:** Precision irrigation, low-carbon farming, and digital agriculture.

**Data and Observation:** Build national-scale EWFC monitoring and modeling platforms.

**Policy Integration:** Synergize energy, water, and food strategies under climate goals.

### China's solar capacity growth sets new record in 2024

China hit another year of record renewable growth, adding 277 GW solar and 79 GW wind capacity in 2024, bringing cumulative solar and wind capacity to 1,627 GW, ahead 58% of the world's installed solar capacity in 2024 alone. With new coal capacity declining sharply and renewables growing rapidly, its power sector is heading towards an inflection point.

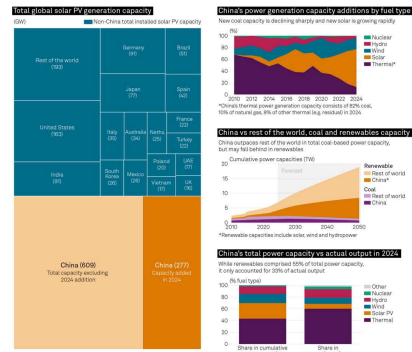

S&P Global Commodity Insights, Jan 24, 2025

# Current Observation Landscape



## China's Long-term Observation: Current Status

**Existing Networks:** Agricultural meteorological stations, hydrological observation, and energy statistics.

**Regional Programs:** North China Plain (grain production), major river basins (e.g., Yellow River, Yangtze).

**Fragmented Systems:** Data often siloed between agriculture, energy, and climate sectors.

**Emerging Initiatives:** Integration efforts under carbon neutrality and food security policies.

Map of seven major river basins and water quality monitoring stations in China

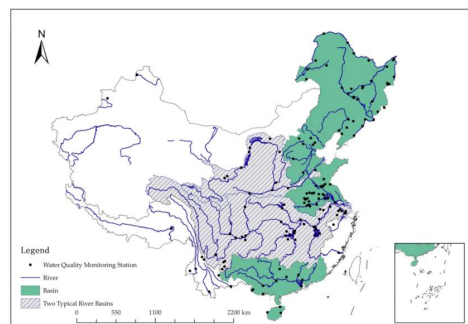

Zou et al. (2021)

(Note: The shaded area represents the Yangtze River Basin and the Yellow River Basin, and the green shapes represent the total area of the other five basins.)

## Key Gaps and Challenges



### Observation Gaps in EWFC Nexus

**Lack of Cross-sector Data:** Energy, water, and agriculture data rarely integrated.

**Temporal & Spatial Gaps:** Long-term continuous datasets are limited, especially at basin and regional scales.

**Technical Limitations:** Need for advanced sensors, real-time monitoring, and big-data analytics.

**Policy and Coordination Issues:** Insufficient collaboration across ministries and research institutions.

Spatial-temporal distribution of WEFF scores in the Yellow River Basin

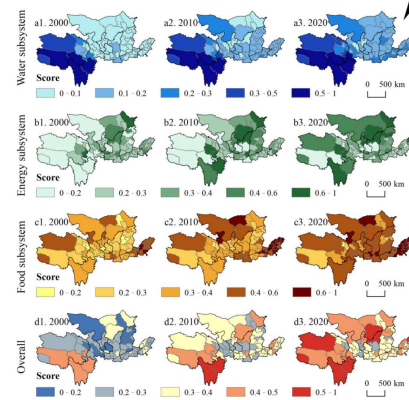

Zhang and Wang (2024)

## Future Directions and Strategies



- ◆ **Integrated Observation Platforms:** Link meteorology, hydrology, energy, and agricultural networks.
- ◆ **Remote Sensing & Big Data:** Use satellites, IoT, and AI to monitor cross-sector dynamics.
- ◆ **National Data Hubs:** Develop open-access platforms for policy and research.
- ◆ **Pilot Projects:** Focus on hotspots (e.g., North China Plain, Yangtze Delta).
- ◆ **Talent & Collaboration:** Train next-gen scientists and foster international cooperation.

Distribution of ground meteorological observation stations in China

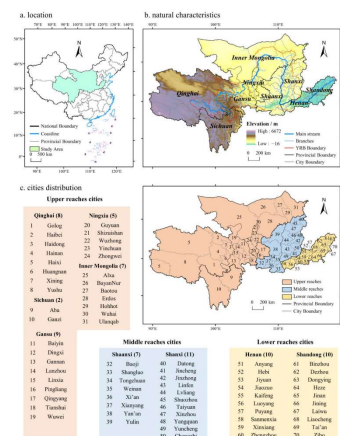

He et al. (2018)

## Global vs China EWFC Challenges



**Global pressures:** The growing demand for energy, water, and food is exacerbated by climate change, population growth, and resource scarcity.

**China's situation:** Uneven water distribution, rapid urbanization, and heavy reliance on coal make the nexus challenges more complex.

**North China Plain:** A hotspot where water stress severely affects agricultural productivity and food security.

**Dual goals:** China is striving for carbon neutrality while ensuring sustainable food and energy supply.

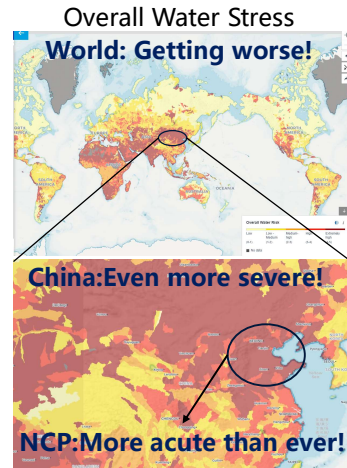

<https://www.wri.org/applications/aqueduct/water-risk-atlas/>

## EWFC Nexus Challenges Comparison

**Global focus:** Coordinating cross-sectoral trade-offs to achieve resource sustainability.

**China's priority:** Managing conflicts between water scarcity, food demand, and high energy use.

**Key challenge:** Limited integration of data and policies across sectors.

**Need:** Localized and innovative solutions to reduce conflicts and enhance resilience.

Synergies and trade-off of WEF nexus with circular bioeconomy

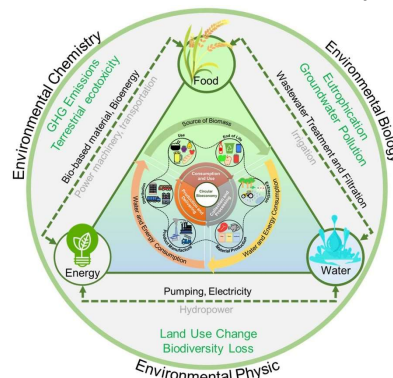

Ansari et al. (2023)

## Research Motivation



**Gap:** Long-term EWFC dynamics in China are poorly understood due to fragmented datasets.

**Importance:** Understanding cross-sector interactions under climate change is crucial for sustainable development.

**Goal:** Build a robust observation-based understanding to guide resource management.

**Policy relevance:** Provide scientific evidence to support national strategies like “dual carbon” and food security policies.

Diagram of the Water-Energy-Food (WEF) Nexus and optimization steps

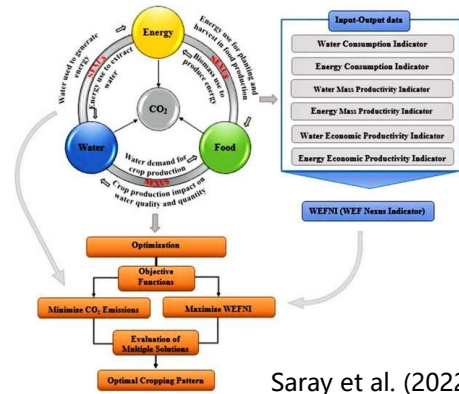

Saray et al. (2022)

## Research Framework (Overview)



**Approach:** Integrating meteorological, hydrological, agricultural, energy, and emissions data.

**Objective:** Reveal key linkages and feedback loops in the EWFC system.

**Outputs:** Identify hotspots, trends, and potential trade-offs across sectors.

**Method:** Combine observational datasets with multi-scale analysis and scenario assessment.

Automated Data Collection & Integration Workflow

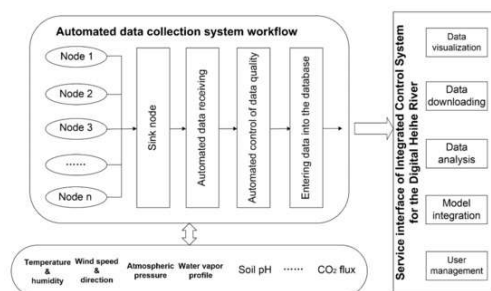

Guo et al. (2021)

## Research Framework (Details)



Conceptual framework of water–energy–food nexus

**Data integration:** Long-term, high-resolution datasets from multiple sectors.

**Multi-scale analysis:** From field observations to basin-scale assessments.

**Feedback analysis:** Quantify interactions and potential synergies/trade-offs.

**Innovation:** Use of remote sensing, AI-based data fusion, and policy-relevant indicators.

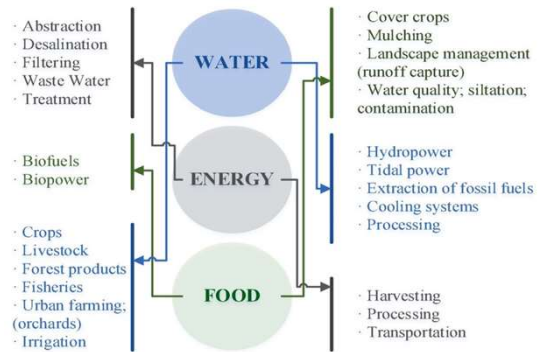

Halim et al. (2021)

## Data Sources and Monitoring Networks

**Meteorological data:** 2,400+ national weather stations providing temperature, precipitation, and solar radiation.

**Hydrological data:** River discharge and groundwater level from key basins (e.g., Yellow River).

**Agricultural data:** Crop yields, irrigation schedules, and fertilizer inputs.

**Energy & emissions:** National energy statistics and carbon emission datasets.

Meteorological station locations over China

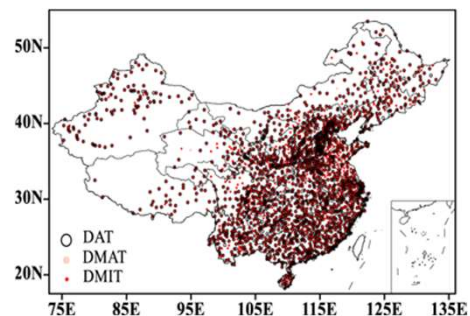

He and Zhao (2018)

## Data Processing and Quality Control

**Homogenization:** Correcting inhomogeneities due to station relocation or instrument changes.

**Gap-filling:** Using interpolation and remote sensing data to fill missing records.

**Validation:** Cross-checking with satellite data and third-party observations.

**Consistency:** Building continuous time series for trend analysis.

Points to consider in the selection of the NP models

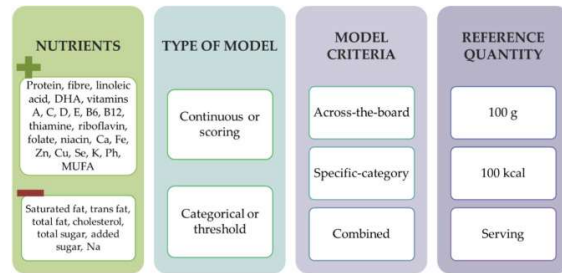

Fernández-Ríos et al. (2021)

## Key Analysis Methods and Indicators

**Indicators:** Water footprint, energy intensity, food productivity, and GHG emissions.

**Analysis methods:** Trend analysis, Mann-Kendall tests, correlation, and network analysis.



**Integration:** Cross-sectoral indicators reveal hidden trade-offs and synergies.

**Visualization:** Use Sankey diagrams or network graphs to show interactions.

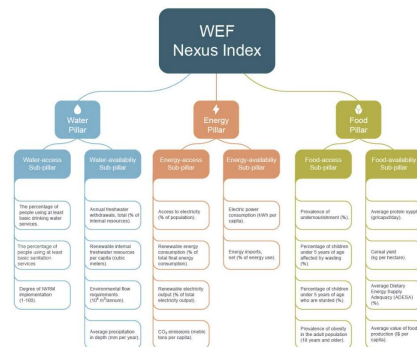
Schematic layout of the WEF Nexus Index



Simpson et al. (2022)

**1** Background and Significance

**2** CERN and Yucheng Station

**3** Main Findings

OUTLINES

## Yucheng Comprehensive Experimental Station

**Established legacy:** A key member of the Chinese Ecosystem Research Network (CERN), with over 30 years of continuous monitoring.

**Integrated platform:** Covers cropland, groundwater, and atmospheric measurements in the North China Plain.

**Monitoring focus:** Water, soil, gas, and crop systems to study energy–water–food–climate interactions.

**Research value:** Provides a unique long-term dataset for understanding agro-ecosystem dynamics and sustainability.

Distribution of CERN research stations

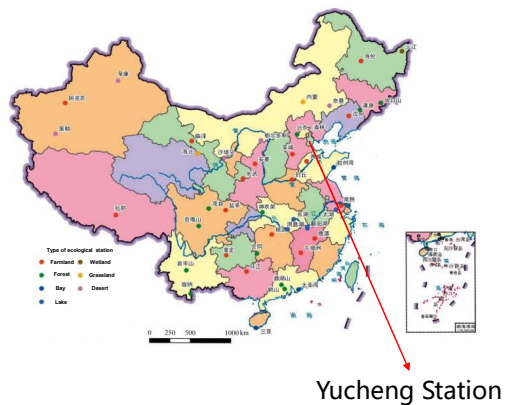

Yucheng Station

## Long-Term Monitoring Program at Yucheng Station

**Multi-Decade Platform:** Continuous agro-ecosystem observation.

**Factorial Field Experiments:** Long-term tillage, warming, fertilization (N-P-K), crop rotation, groundwater / irrigation regimes, straw return.....

**Comprehensive Monitoring:** Soil-water-gas-crop measurements + carbon & water flux (eddy covariance + chambers).

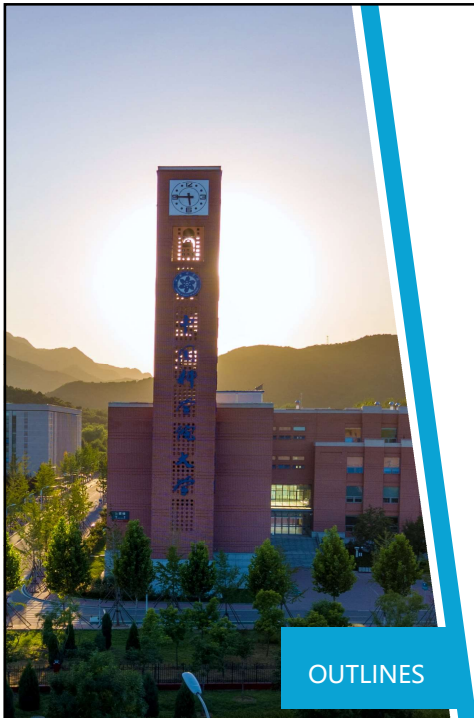
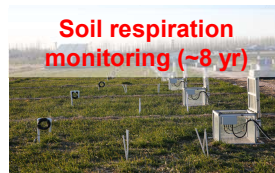
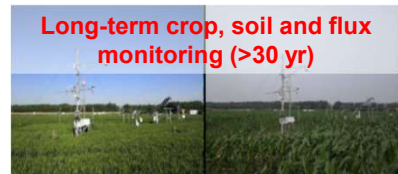

OUTLINES



1 Background and Significance

2 CERN and Yucheng Station

3 Main Findings

# Crop yield and soil organic carbon

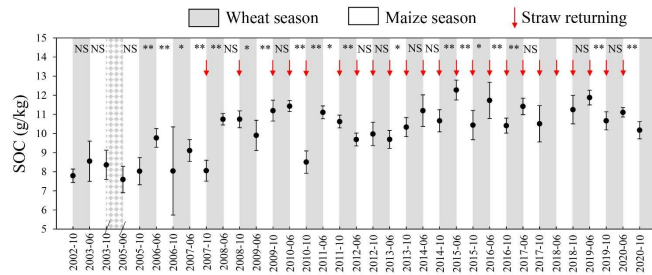
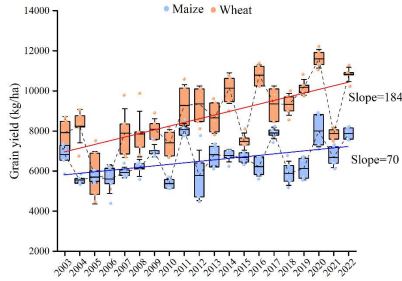

- **Yield:** Over the past 20 years, winter wheat and summer maize yields increased by 70 kg ha<sup>-1</sup> yr<sup>-1</sup> and 184 kg ha<sup>-1</sup> yr<sup>-1</sup>, respectively.
- **SOC:** SOC increased during the wheat season (0.58 g kg<sup>-1</sup> yr<sup>-1</sup>) but declined during the maize season (-0.72 g kg<sup>-1</sup> yr<sup>-1</sup>). *Wang et al. (2025)*

# Long term carbon flux (EC)

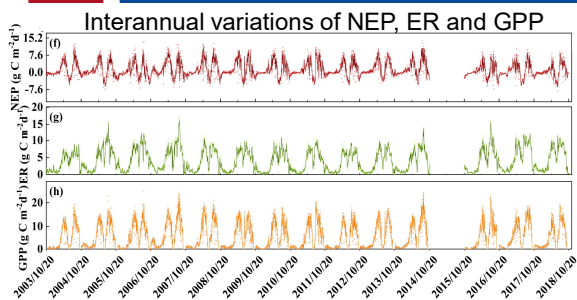

Carbon balance of the wheat-maize rotation system

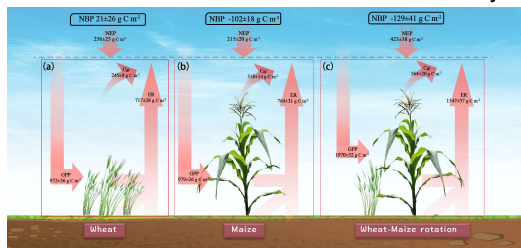

- **Seasonal carbon dynamics:** Wheat and maize fields acted as CO<sub>2</sub> sources during early growth but as sinks in later stages.
- **Interannual NEP controls:** NEP variability was mainly driven by CUP length, phenology timing, and NEP<sub>max</sub>.
- **Long-term carbon budget:** Wheat was nearly carbon neutral, while maize remained a net carbon source, resulting in an annual source of 129±41 g C m<sup>-2</sup>.

*Yue et al. (2023ab)*

## Effects of tillage and N fertilizer on CO<sub>2</sub> emissions

The combination of no-tillage and moderate nitrogen fertilization can effectively reduce soil CO<sub>2</sub> emissions and increase corn yields, demonstrating its potential as an eco-friendly farming method.

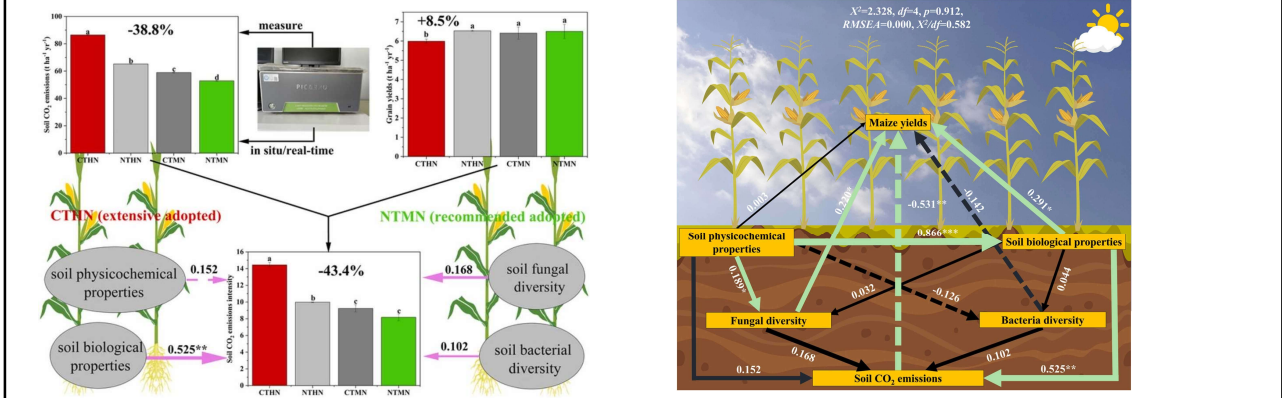

## Effects of straw mulching and N fertilizer on CO<sub>2</sub> emissions

- ◆ In the study area, no-tillage (NT) combined with straw mulching has a greater advantage on CO<sub>2</sub> emissions reduction by an average of 10.82% to 19.14%.

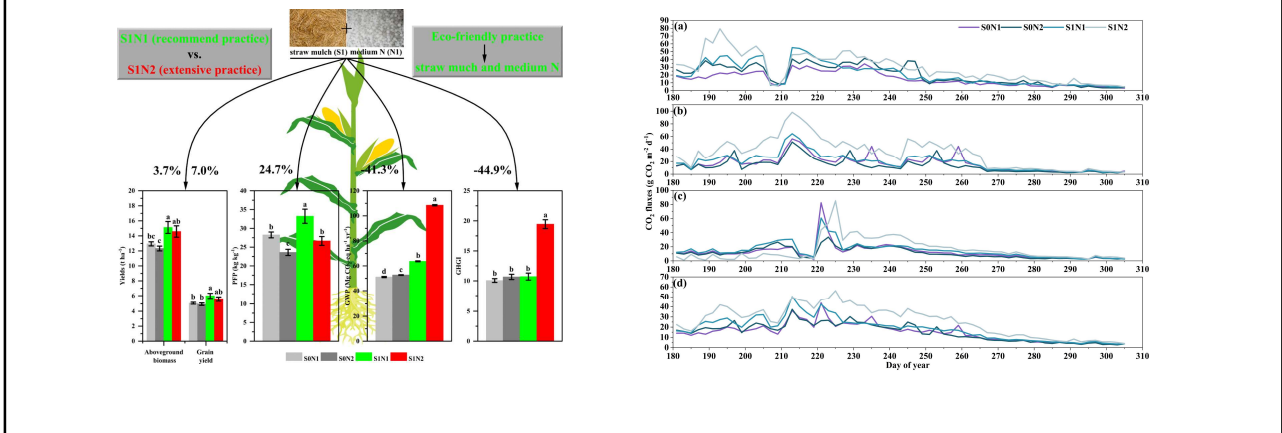

## Trade-off between maize yield and CO<sub>2</sub> emissions

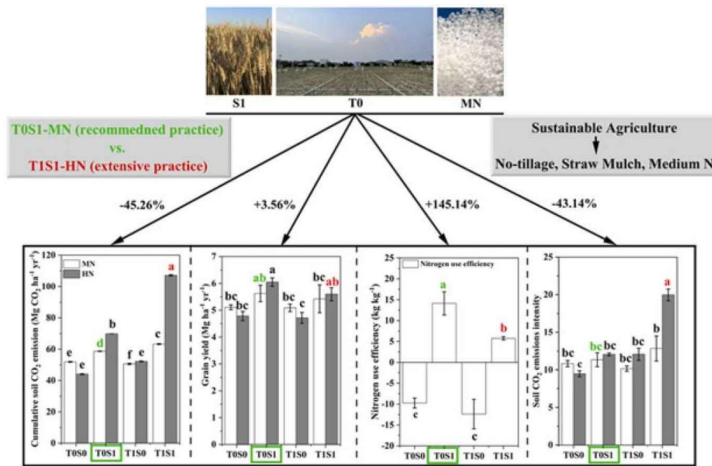

- Combining **no-tillage, straw coverage, and moderate nitrogen fertilization** can achieve a balance between corn yield and soil CO<sub>2</sub> emissions.

## Integrated Insights & Implication



- ❑ **EWFC Nexus Lessons:** Yucheng data demonstrate the importance of coordinated water and nitrogen management.
- ❑ **Sustainability impact:** Proper agronomic practices can reduce agricultural inputs, energy use, and greenhouse gas emissions while stabilizing crop yields under climate change.
- ❑ **Policy relevance:** Findings can support China's food security and carbon neutrality strategies.
- ❑ **Next steps:** Scaling up to regional EWFC observations with multi-station integration.

## Main references



- Li, Z. X., Zhang, Q., Li, Z., Qiao, Y., Du, K., Yue, Z., Tian, C., Leng, P., Cheng, H., Chen, G., & Li, F. D. (2023). Responses of soil CO<sub>2</sub> emissions to tillage practices in a wheat-maize cropping system: A 4-year field study. *Field Crops Research*, 294, 108832. <https://doi.org/10.1016/j.fcr.2023.108832>
- Li, Z. X., Zhang, Q. Y., Li, F. D., Li, Z., Qiao, Y. F., Du, K., Yue, Z. W., Tian, C., Leng, P. F., Cheng, H. F., & Chen, G. (2023). Soil CO<sub>2</sub> emission reduction with no-tillage and medium nitrogen fertilizer applications in semi-humid maize cropland in North China Plain. *European Journal of Agronomy*, 147, 126939. <https://doi.org/10.1016/j.eja.2023.126939>
- Li, Z. X., Zhang, Q. Y., Li, Z., Qiao, Y. F., Du, K., Yue, Z. W., Tian, C., Leng, P. F., Cheng, H. F., Chen, G., & Li, F. D. (2023). Responses of soil greenhouse gas emissions to no-tillage: A global meta-analysis. *Sustainable Production and Consumption*, 36, 479–492. <https://doi.org/10.1016/j.spc.2023.04.012>
- Yue, Z., Li, Z., Yu, G., Chen, Z., Shi, P., Qiao, Y., Du, K., Tian, C., Zhao, F., Leng, P., Li, Z., Cheng, H., Chen, G., & Li, F. D. (2023). Climate controls over phenology and amplitude of net ecosystem productivity in a wheat-maize rotation system in the North China Plain. *Agricultural and Forest Meteorology*, 333, 109411. <https://doi.org/10.1016/j.agrformet.2023.109411>
- Yue, Z. W., Li, Z., Yu, G., Chen, Z., Shi, P., Qiao, Y., Du, K., Tian, C., Zhao, F., Leng, P., Li, Z., Cheng, H., Chen, G., & Li, F. D. (2023). Seasonal variations and driving mechanisms of CO<sub>2</sub> fluxes over a winter-wheat and summer-maize rotation cropland in the North China Plain. *Agricultural and Forest Meteorology*, 342, 109699. <https://doi.org/10.1016/j.agrformet.2023.109699>
- Li, Z. X., Zhang, Q., Qiao, Y., Du, K., Yue, Z., Tian, C., Leng, P., Cheng, H., Chen, G., & Li, F. D. (2022). Trade-offs between high yields and soil CO<sub>2</sub> emissions in semi-humid maize cropland in northern China. *Soil and Tillage Research*, 221, 105412. <https://doi.org/10.1016/j.still.2022.105412>
- Li, Z. X., Zhang, Q. Y., Qiao, Y. F., Du, K., Yue, Z. W., Tian, C., Leng, P. F., Cheng, H. F., Chen, G., & Li, F. D. (2022). Influence of straw mulch and no-tillage on soil respiration, its components and economic benefit in a Chinese wheat-maize cropping system. *Global Ecology and Conservation*, 34, e01952. <https://doi.org/10.1016/j.gecco.2022.e01952>
- Wang, N., Ai, Z., Zhang, Q., Leng, P., Qiao, Y., Li, Z., Tian, C., Shi, X. J., Cheng, H. F., Chen, G., & Li, F. D. (2025). The variations of wheat-maize production, soil organic carbon, and carbon footprints: Insights from a 20-year on-farm observational experiment in the North China Plain. *Frontiers in Plant Science*, 16, 1547431. <https://doi.org/10.3389/fpls.2025.1547431>
- Wang, N., Ai, Z., Zhang, Q., Leng, P., Qiao, Y., Li, Z., Tian, C., Cheng, H. F., Chen, G., & Li, F. D. (2025). Influence of long-term inorganic fertilization and straw incorporation on soil organic carbon: Roles of enzyme activity, labile organic carbon fractions, soil aggregates, and microbial traits. *Agriculture, Ecosystems & Environment*, 392, 109758. <https://doi.org/10.1016/j.agee.2025.109758>
- Wang, N., Ai, Z., Zhang, Q., Leng, P., Qiao, Y., Li, Z., ... & Li, F. D. (2024). Impacts of nitrogen (N), phosphorus (P), and potassium (K) fertilizers on maize yields, nutrient use efficiency, and soil nutrient balance: Insights from a long-term diverse NPK omission experiment in the North China Plain. *Field Crops Research*, 318, 109616. <https://doi.org/10.1016/j.fcr.2024.109616>

## Acknowledgement



International Ecosystem Management Partnership  
国际生态系统管理伙伴计划

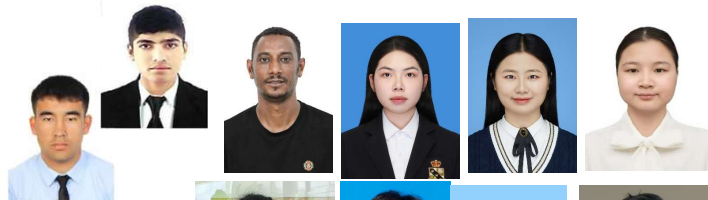



  中国科学院大学  
University of Chinese Academy of Sciences

# Thanks for your attentions!

Dr./Prof./Director of Station Fadong LI

Shandong Yucheng Agro-ecosystem National Observation and Research Station (SYA-NORS)  
Yucheng Comprehensive Experiment Station  
Institute of Geographic Sciences and Natural Resources Research, Chinese Academy of  
Sciences(IGSNRR-CAS)  
University of Chinese Academy of Sciences (UCAS)

No.11A, Datun Road, Chaoyang District, Beijing, 100101, China

E-mail: [lifadong@igsnr.ac.cn](mailto:lifadong@igsnr.ac.cn)



**Advancing women-led pathways toward an Africa devoid of unemployment, hunger, climate risks, and inadequate human settlements: A scientific treatise**

Author: Professor Nokuthula Sibiyi, MUT Vice-Chancellor & Principal

Presented at the EnergyWaterFoodClimate Nexus Summit, Hungary, August 2025

This paper articulates a research-informed framework, which I would like to advance for transforming Africa into a continent characterised by full employment, food sovereignty, climate resilience, and dignified human settlements. Emphasising women’s leadership as foundational, my analysis draws on empirical evidence, which align with SDGs 1–11 and Agenda 2063 aspirations, and proposed integrated, contextually adaptive strategies. It underscores how gender-conscious policy reformation, enhancement of small-scale economies, sustainable food systems revitalisation, climate adaptation, and participatory urban planning can collectively drive inclusive and sustainable development on the continent.

In my lifelong academic and advocacy journey, I have focused intensely on the **advancement of women**, underpinned by both empirical analysis and emancipatory praxis. I contend that the systemic challenges we face today, particularly in South Africa’s townships, are similar to those in the United States and would generally be historically marginalised Black neighbourhoods or inner-city urban ghettos that developed through systemic segregation and economic exclusion, where unemployment rates exceed 60% and the Gini coefficient ranks among the highest globally—are deeply rooted in historical injustices, limited access to resources, and structural inequalities. These factors exacerbate the plight of marginalised communities, necessitating a multifaceted approach to address and rectify the ongoing disparities faced by women in these contexts.

This paper explicitly aligns with:

- SDG Goals (notably SDG 1: No Poverty, SDG 2: Zero Hunger, SDG 5: Gender Equality, SDG 7: Affordable and Clean Energy, SDG 11: Sustainable Cities and Communities, SDG 13: Climate Action),
- Agenda 2063 (particularly Aspiration 6: “An Africa whose development is people-driven, relying on the potential of women and youth”; Aspiration 7: “Africa as a strong, united, and influential global player”), providing a normative and strategic base for African women-focused development.

Let me start off by sharing a few disturbing factors around unemployment in South Africa:

- The official unemployment rate: 32.9% as of the first quarter of 2025.
- Expanded unemployment (including discouraged seekers): 42.6%.
- Youth (15–24) unemployment: ~61%.

These data underscore entrenched exclusion from formal economies. Considering contemporary socio-economic challenges, I propose a multifaceted framework aimed at fostering sustainable economic growth and social equity. This framework comprises the following components:

**1. Reforming labour law:** It is imperative to revise existing labour legislation to reduce the barriers faced by micro and small enterprises (SMMEs) in their capacity to employ full-time workers. Such reform would promote job creation and enhance the operational viability of SMMEs, which are vital to economic resilience.

**2. Scaling skills development in the green economy:** There is a pressing need for the expansion of skills development initiatives within the green economy, particularly targeted at women and youth. Training programmes should focus on sectors such as renewable energy and resource management, ensuring alignment with the objectives of Post-School Education and Training (PSET) institutions (Universities and TVET Colleges). This approach will not only facilitate workforce participation but also support the transition towards sustainable economic practices.

**3. Supporting sustainable, labour-intensive production models:** Endorsing production models that are both sustainable and labour-intensive is crucial for creating mass employment opportunities while simultaneously mitigating carbon emissions. Such models can serve as a catalyst for economic inclusion and environmental stewardship.

This proposed framework draws upon an extensive body of literature that champions labour-intensive development as a viable model for just transitions. It emphasises the critical intersection of equitable employment and climate action. Notably, women, particularly those residing in rural and township areas, emerge as both significant beneficiaries and proactive implementers of these sustainable models, thereby reinforcing their agency in the socio-economic landscape.

The next aspect I wish to touch on is **food sovereignty and traditional nutrition systems**. A comprehensive historical analysis reveals that **colonisation significantly disrupted Africa's indigenous food systems**, which were characterised by communal farming, seed preservation, and the cultural significance of nourishment. These systems were supplanted by dependency-driven structures that undermined local agricultural practices.

Considering these historical injustices, I advocate for research-driven strategies aimed at restoring and revitalising Africa's food systems. These strategies should include:

- Revitalisation of indigenous seeds and agricultural practices: This entails instituting an approach that promotes resilience, enhances biodiversity, and preserves cultural continuity within agricultural systems.
- Empowerment of women farmers: Recognising that women are responsible for the majority of food production yet have access to a significantly limited proportion of land and agricultural resources, efforts must be made to enhance their support and agency within the agricultural sector.
- Reframing food as a human right and cultural asset: It is essential to reconceptualise food not merely as a commodity but as a fundamental human right and an intrinsic cultural asset, thereby reclaiming agency in the food system.

The implementation of these measures is anticipated to alleviate "hidden hunger" associated with micronutrient deficiencies, improve public health outcomes, strengthen household nutrition, and re-anchor food sovereignty within communities. Through these initiatives, we can contribute to the restoration of sustainable and equitable food systems in Africa.

With regards to climate resilience and adaptation, let us remember that despite contributing under 5% to global emissions, Africa bears disproportionate climate impacts. In South Africa, reliance on fossil fuels yields heavy per capita GHG emissions—road transport emissions, for instance, rose approximately 2.6% annually from 2000 to 2009.

It is for this reason that I propose a **Women-Centred Climate Strategy**, specifically focusing on:

- Capacity-building for women in clean energy and natural resource management.
- Encouraging labour-intensive clean technologies, reducing dependency on energy-intensive inputs.
- Embedding adaptation planning into agriculture, infrastructure, and training systems.

The paper recommends **fast-tracking African Climate Change Programmes**—encompassing resilient agriculture, sustainable forestry, and national adaptation plans—with women leading design and implementation to ensure inclusive, locally grounded solutions.

Ladies and gentlemen, it would be remiss of me **not to argue for sustainable human settlements** because rapid urbanisation in Africa demands that settlement planning integrate climate adaptation with inclusivity. **Digital technologies** (climate mapping, land-use monitoring, infrastructure optimisation) are critical tools in this transformation.

I would like to promote:

- Participatory urban governance—engaging residents, particularly women, in planning and execution.
- Digital infrastructure to aid real-time climate responsiveness (e.g., flood alerts, energy-efficient lighting), efficient infrastructure, and hazard mapping.
- Designing resilient, dignified living environments, moving beyond treating informal settlements as temporary.

Throughout my career, I have been a staunch advocate for women's leadership, particularly in relation to critical risk factors encompassing energy, water, food

security, and climate change. My research argues that women play an indispensable role in food production, community management, and adaptation strategies. However, persistent structural biases in access to land, financial resources, training, and governance mechanisms significantly undermine their equitable participation and voice.

From a normative perspective, **gender equality**, as articulated in Sustainable Development Goal 5 (SDG 5), is a **fundamental human right**. Pragmatically, the realisation of the Africa we envision hinges on the incorporation of women’s leadership in shaping adaptation initiatives, driving economic transformation, and informing settlement planning frameworks.

Agenda 2063’s Aspiration 6 explicitly emphasizes the necessity of harnessing the full potential of both women and youth. Thus, women's leadership should not be viewed as a peripheral concern; rather, it is an essential imperative for achieving sustainable development across the continent.

In conclusion, please allow me to share **some key recommendations** that the EWFC Hungary, 2025 should note:

AREA	KEY RECOMMENDATIONS
Employment	Reform labour laws; scale green-skills training; prioritise SMMEs in clusters and townships.
Food	Revitalise indigenous agriculture; support women farmers; reframe food as a right and culture.
Climate resilience	Train women in clean energy; use labour-intensive, low-carbon tech; implement climate-adaptation plans.
Human settlements	Embed women in participatory planning; deploy digital tools for resilience; transform informal areas.
Policy enablers	Align interventions with SDGs and Agenda 2063; fund women-led institutions; ensure community governance.

This framework is predicated on a scientific, intersectional, and transformative approach, integrating empirical evidence and decades of research on gender dynamics. By synthesising the domains of employment, food systems, climate resilience, and urban planning within a women-led, rights-based framework aligned with the Sustainable Development Goals (SDGs) and Agenda 2063, the model articulates a strategic roadmap for cultivating an autonomously self-determined Africa.

As both a scholarly manifesto and a pragmatic policy guide, this work advocates for an African continent that actively pursues its liberation through the agency and leadership of its women, rather than relying on external saviours.

I would like to extend my gratitude to colleagues who are here and are actively engaged in research on climate, water, food, energy, and human settlements. Most importantly, to colleagues who are in the internationalisation, marketing, and communications space for their experiential insights and knowledge, which form the foundation of this research. This paper is informed by interdisciplinary studies in internationalisation, gender and development, climate justice, urban resilience, and food sovereignty.

I thank You.



PROMOTIONS-  
KOLLEG NRW

The Graduate School NRW –  
Motivation of founding and initial experiences

→ *Connecting and uncovering scientific resources*

Graduate School for Applied Sciences in NRW |  
NEXUS 2025 | Miskolc / Hungary

0 | Content

Graduate School for Applied Research in North Rhine-Westphalia



1. Who we are
2. Motivation
3. Initial Experiences
4. Why we are here



August 28, 2025 | Klaus Maas | David Gilgen

# 1 | Who we are

Graduate School for Applied Research in North Rhine-Westphalia



## Klaus Maas

- Prof. for Environmental Information Systems
- PhD in Mining
- Member of University Council
- Dean of the Department Technique and Systems
- Ombudsperson, Mediator

## David Gilgen

- Coordination of Department Technology and Systems
- PhD in History and Civilisation (IUE)
- Member of PK NRW Senat
- Member of Commission of Responsibility in Science



August 28, 2025 | Klaus Maas | David Gilgen

# 1 | Who we are

Graduate School for Applied Research in North Rhine-Westphalia



## State of North Rhine-Westphalia

- 18 Mio. Habitants
- Largest German State
- 66 Universities and Universities of Applied Sciences
- 720.000 Students

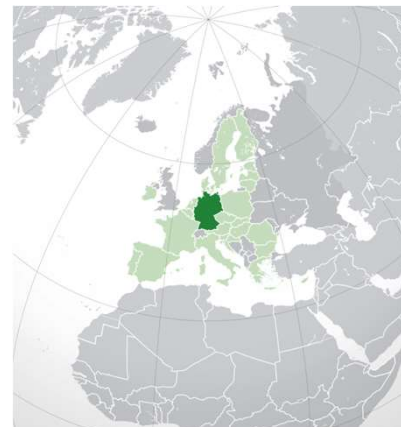

August 28, 2025 | Klaus Maas | David Gilgen

## 2 | Motivation

Graduate School for Applied Research in North Rhine-Westphalia



### University vs. University of Applied Sciences

#### Universities

- Basic Research
- (Pure) Research & Teaching
- Wide Catchment Area

#### University of Applied Sciences

- Applied Research & Transfer
- Teaching & (Applied) Research
- Regional Catchment Area

The two types of university are converging.

By law, Universities of Applied Sciences do not have the right to award doctorates.

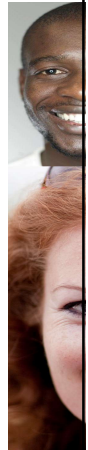

August 28, 2025 | Klaus Maas | David Gilgen

## 2 | Motivation

Graduate School for Applied Research in North Rhine-Westphalia



### Educational Permeability

Studying at state universities in Germany is free of charge.

The Bachelor's/Master's structure is standardized in Europe (exception: medicine, law)

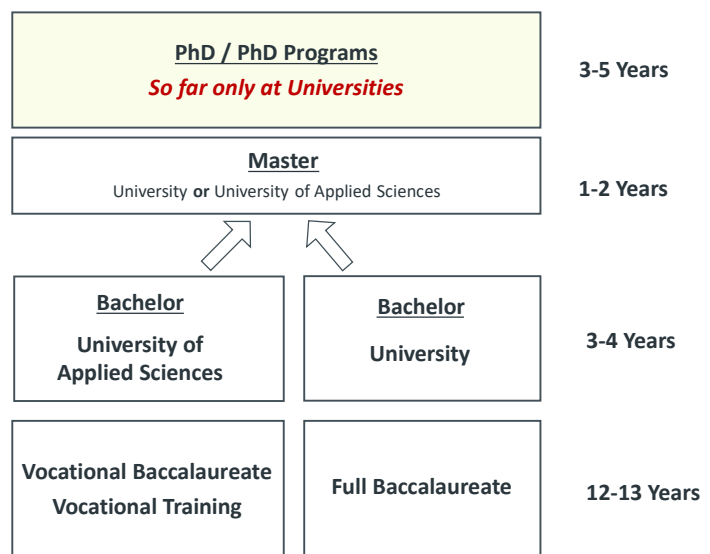

August 28, 2025 | Klaus Maas | David Gilgen

## 2 | Motivation

Graduate School for  
Applied Research in North  
Rhine-Westphalia



### The University Mode

#### Mode 1: Epistemic (epistemological) system of science:

- Principle of methodological doubt and power of facts
- Sovereignty of scientific expert community
- Disciplinary frame of reference
- Truth-seeking within science

Good examples: Pure Mathematics or Astronomy

August 28, 2025 | Klaus Maas | David Gilgen

[Schneidewind, U.: Transformative Wissenschaft 2015]

[Strohschneider, P.: Zur Politik der transformativen Wissenschaft 2014]

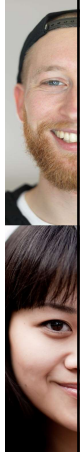

## 5 | Motivation

Graduate School for  
Applied Research in North  
Rhine-Westphalia



### The Applied Mode

#### Mode 2: Society becomes an integral part of science:

- Social transformation processes are observed and described **and** may change the research design
- Principle of transdisciplinarity
- Action and intervention research (Real-world labs)
- Sensitizes researchers to the limits of their own discipline
- *Often with reference to regional economic, social and natural environment*

**Important:** Mode 2 in no way violates the rules of good scientific practice

August 28, 2025 | Klaus Maas | David Gilgen

[Schneidewind, U.: Transformative Wissenschaft 2015]

[Strohschneider, P.: Zur Politik der transformativen Wissenschaft 2014]

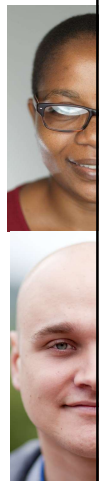

## 2 | Motivation

Graduate School for Applied Research in North Rhine-Westphalia



Graduate School for Applied Sciences in NRW

- As we said, universities of applied sciences do not have the right to award doctorates by law
  - *But there is high quality research also done at Universities of applied science*
  - What can be done?
- Found an institution equivalent to a university



[Fig.: Racing Team]

August 28, 2025 | Klaus Maas | David Gilgen

## 3 | Initial Experiences

Graduate School for Applied Research in North Rhine-Westphalia



Graduate School for Applied Sciences in NRW

- 20 Universities of Applied Sciences founded a Graduate School
- 7 Years and 7000 Pages



August 28, 2025 | Klaus Maas | David Gilgen

### 3 | Initial Experiences

Graduate School for Applied Research in North Rhine-Westphalia



**Graduate School for Applied Sciences in NRW**

- Start of planning in 2016
- Anchored in law: 2019
- Evaluation in 2021
- Right to award PhDs 2022
- First enrollments in 2023
- Until today: 526 professorial and 453 doctoral members
- Professorial members must have a strong research record
- Repeated quality check of publication record an third party founds

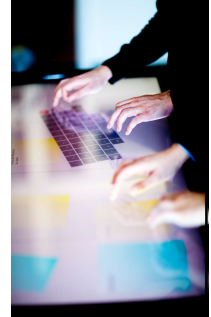

August 28, 2025 | Klaus Maas | David Gilgen

### 3 | Initial Experiences

Graduate School for Applied Research in North Rhine-Westphalia



**Graduate School for Applied Sciences in NRW**

The German Council of Science and Humanities is the oldest science policy advisory body in Europe

**Evaluation** by the German Council of Science and Humanities in 2021



August 28, 2025 | Klaus Maas | David Gilgen

### 3 | Getting started

Graduate School for Applied Research in North Rhine-Westphalia



**Graduate School for Applied Sciences in NRW**

#### Academic Organisation

- 8 departments
- 12 different doctoral programs
- Doctoral supervision teams
- Staff: 25
- First graduation ceremony 11/2025

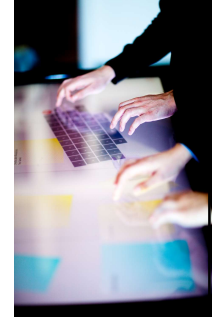

August 28, 2025 | Klaus Maas | David Gilgen

### 3 | Initial Experiences

Graduate School for Applied Research in North Rhine-Westphalia

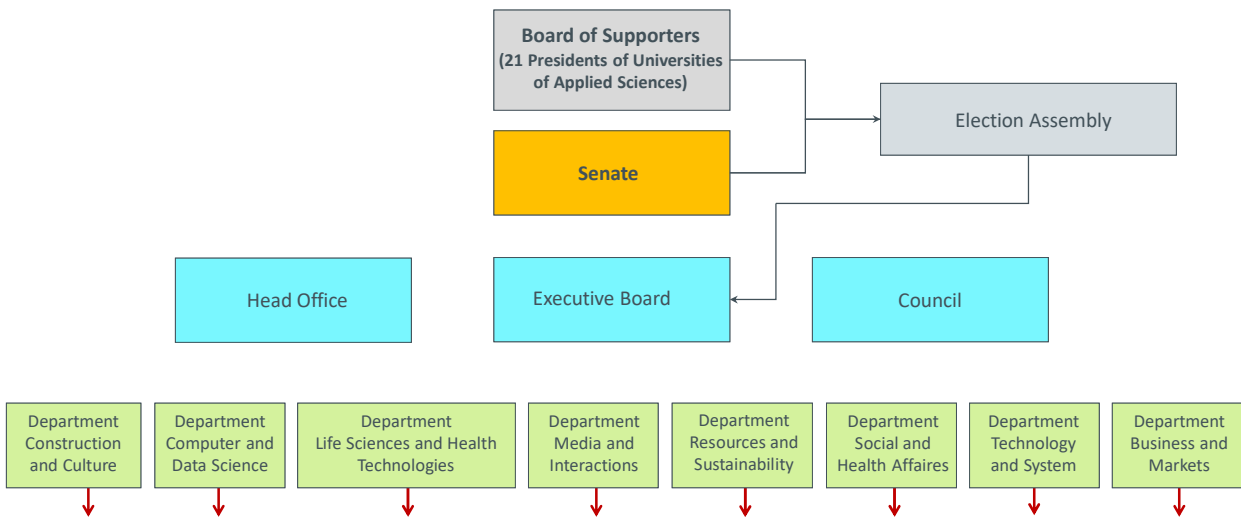

Each: Doctoral Examination Board und Doctoral Programme, Director, Board, Managing Director

August 28, 2025 | Klaus Maas | David Gilgen

### 3 | Technology and Systems

Graduate School for  
Applied Research in North  
Rhine-Westphalia



**Graduate  
School for  
Applied  
Sciences in  
NRW**

- Focus I.: Cyber Physical Systems
- Focus II.: Instrumentation and Control
- 65 Professors (40/25)
- 50 PhD students
- Doctoral program: Cyber Physical Systems
- First thesis defense 09/2025

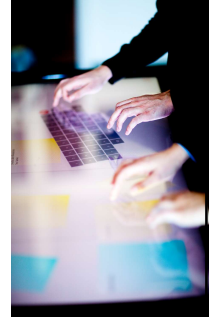

August 28, 2025 | Klaus Maas | David Gilgen

### 4 | Why we are here

Graduate School for  
Applied Research in North  
Rhine-Westphalia



#### Our next Goals

- Establishing sustained international cooperation
- Strengthen international networking of PhD students
- Joint research proposals with international partners



[Fig.: InIT]

August 28, 2025 | Klaus Maas | David Gilgen



Thanks for your attention!

Prof. Dr.-Ing. Klaus Maas  
klaus.maas@th-owl.de

Dr. David Gilgen  
david.gilgen@pknrw.de



## From Energy Industry to Agriculture:

The Path of Lignite Toward Sustainability

**MVM** Mátra Energia

## Lignite for Circular Economy

### Lignite before 2025

- Primary use is electricity generation
- Synthetic natural gas production

### Specific fields for sustainable management, 2025

- Agriculture
- Environmental protection
- Environmental industry

### Results and new products, 2025

- ✓ **New organic soil improver products with certification according to 2019/1009 EU regulation**
- ✓ **Agricultural tests at large-scale level**
- ✓ **Biowastes: biogas digestate treatment at laboratory and pilot-scale level**
- ✓ **Soil remediation**

2

**MVM** Mátra Energia



3

- The lignite of the Mátra and Bükkalja was formed some 5 to 8 million years ago.
- The quality of lignite is characterised by a comparatively low calorific value and a high ash and moisture content.
- The lignite production in Visonta and Bükkábrány takes place with surface/open-pit mining technology.
- Coal excavation is performed with bucket-chain excavators and one-bucket excavators.



4



**Current Agriculture**

Frequent use of inorganic fertilizers and pesticides in a high amount caused significant degradation on soil structure and biological activity.

Lignite can reflect to these problems thanks to its high organic carbon content, adsorption and cation exchange capacity.

5

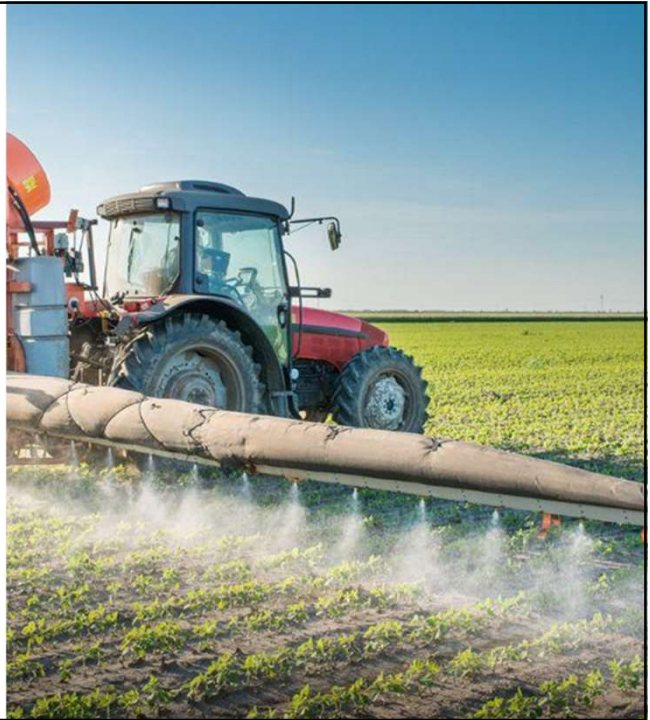

**Importance and role of lignite in fertilizer production as component material**

- ✓ Organic
- ✓ Organo-mineral
- ✓ Compost
- ✓ Soil improver
- ✓ Plant biostimulant
- ✓ Growing medium



Lignite is considered as a natural biochar that plays an important role in remediation of polluted soils and amelioration due to its high organic carbon content. The most relevant other characteristics are:

- particle size,
- cation exchange capacity,
- specific surface area,
- electrical conductivity.



- **Animal manure** treatment with lignite contributes to reduction of odour, ammonia emission during storage and spreading procedures at full-scale level.
- Lignite plays a major role in adsorption of inhibitors, harmful compounds that are present due to anaerobic conditions in manure pile.



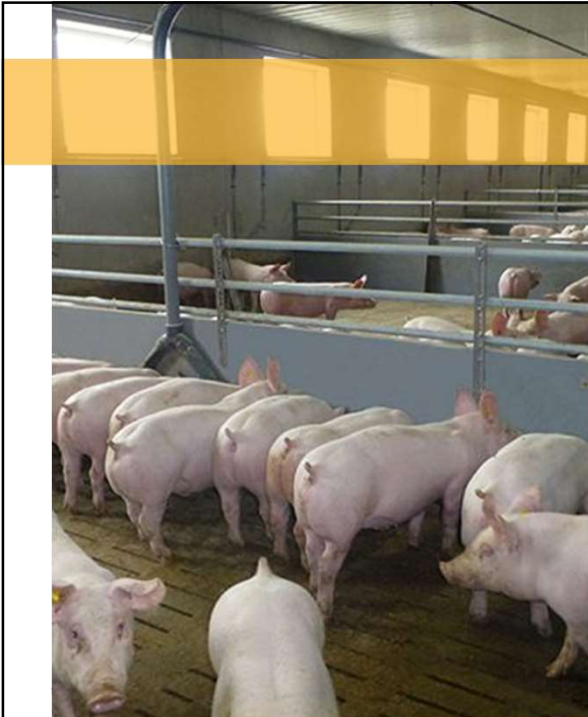

**Animal husbandry and biogas digestate treatment:**

- pH stabilization
- odour reduction
- minimizing greenhouse gas emission
- adsorption of ammonium-N
- improving structure and consistency
- optimizing carbon to nitrogen ratio



**Lignite plays a significant role in the controlled composting process:**

- Maintaining thermophilic stage in case of composting animal by-products,
- Reducing leakage water amount during the complete composting procedure,
- Improving compost stability according the most relevant maturity indicators: oxygen uptake, germination index.

10





### Pelletization and added value products with lignite

In order to create high quality pelleted products, it is necessary to reach 85-90 % of moisture content that process has a substantial energy demand. Lignite has a beneficial effect on this process thanks to its high water-adsorption and holding capacity.



- Lignite is well known to have a high humic acid content which can be recovered with a suitable technology.
- Substrates and humic acid concentrates can be prepared, the use of which is a well-known and accepted practice in agriculture. The production of humic acid preparations is a growing business.

Lignite samples from Visonta location		
	Mean value	Maximum
Readily available humic acid %	16,08	34,50
Total humic acid %	27,59	50,60

Lignite samples from Bükkábrány location		
	Mean value	Maximum
Readily available humic acid %	23,78	44,80
Total humic acid %	31,9	55,20



## Reducing greenhouse gas emission



- Through lignite agricultural use, the effect of inorganic fertilizers or other organic fertilizers, biostimulants can be enhanced, their amount can be reduced to a minimum level.
- Applying 1,000,000 tons/year of lignite, the amount of conventional fertilizer use can be halved.
- The use of lignite reduces the country's CO<sub>2</sub> emissions by 1-1.7 million tons/year, which represents 1.7-2.9% of total emissions.

13

**MVM** Mátra Energia

## Adsorption of ammonium-nitrogen, reducing odour emission

**Mix: lignite + biogas digestate according to 2 to 1 weight ratio**

TS w/w % of biogas digestate: **4,08**

Total ammonium-nitrogen content of digestate mg/L: **5849**

After 14 days of drying procedure, dry matter content of lignite – digestate mix increased from 40 to 90 %. Concentration of ammonium-nitrogen in mix changed from 1958 mg/kg-to 3201 mg/kg, then it was moderated to 2881 mg/kg.

Time of incubation (days)	TS (%)	oTS (%)	NH <sub>4</sub> -N mg/kg	TN mg/kg
0	40,0	51,5	1958	4880
14	92,0	49,9	3201	
32	94,5	51,1	2881	10400

14

**MVM** Mátra Energia

## Filtration of saline solution through lignite powder at laboratory-scale – amelioration of saline soils

Sample number	Conditions	Residual concentration	
1	Solution infiltration through filter paper	2,7 g/L	1 L
2	1 g of fine lignite powder on filter paper	1,25 g/L	0,5 L
3	4 g of coarse lignite powder on filter paper	1,85 g/L	0,5 L
4	8 g of coarse lignite powder on filter paper	1,35 g/L	0,5 L
5	4 g of fine lignite powder – mixing in 0,5 litre of solution and infiltration	2,55 g/L	0,5 L
6	4 g of coarse lignite powder – mixing in 0,5 litre of solution and infiltration	1,55 g/L	0,5 L

Original concentration: 4 g/L NaCl solution

15

**MVM** Mátra Energia

15





# Water Management for the Sustainability

Balázs Örfi - Director Production Center







26.08.2025

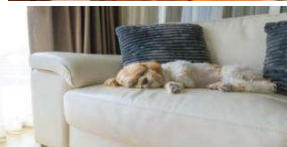

## Uses of MDI and TDI products

**Producing 7 million tons** to this day



Furnitures	Sports	Automotive	Building construction
  	  	  	  



## Uses of Chlorine - alkali products

**Producing 10 million tons to this day**



Pharmaceutical Industry	Safe drinking-water	Environmental Protection	Clean Technologies
			<p><b>Ultra-pure Silicon production with chlorine</b></p>



## Uses of PVC products

**Producing 11 million tons to this day**



Sports	Wrapping	Safety	Building construction
			<p><b>PVC:</b></p> <ul style="list-style-type: none"> <li>- Reuse;</li> <li>- Plastic windows;</li> <li>- CO<sub>2</sub> reduction</li> </ul>



## BorsodChem Zrt. Sites

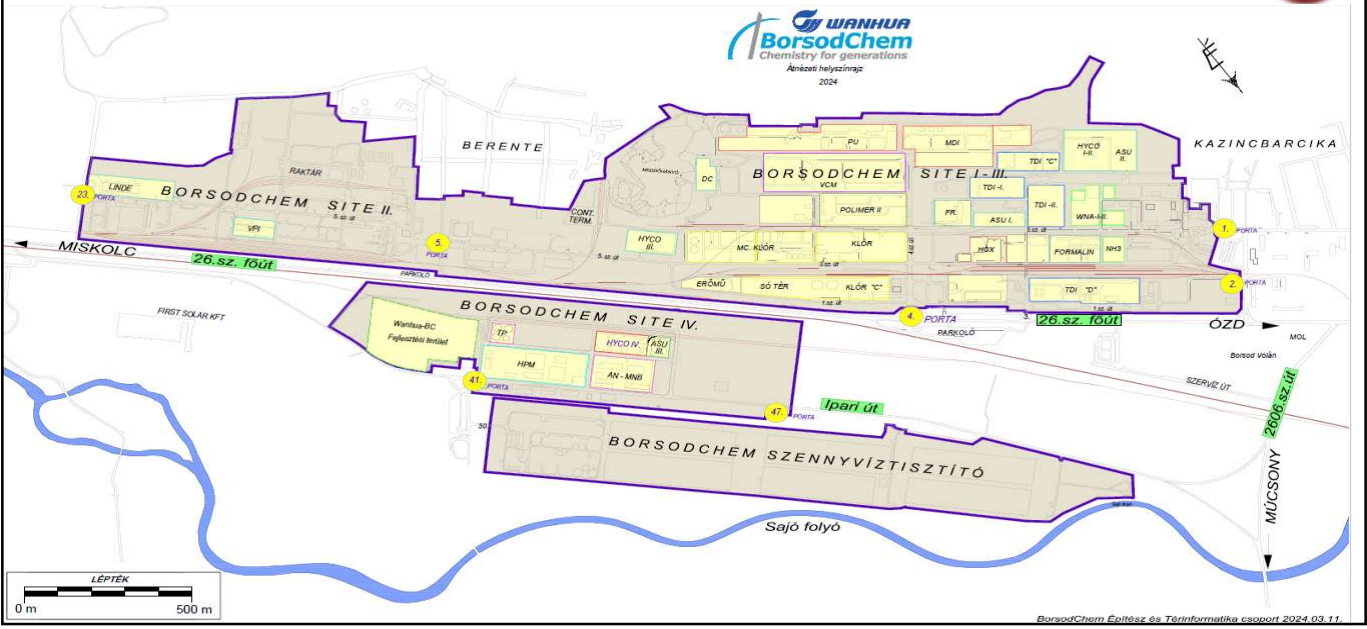

BorsodChem Építész és Térinformatika csoport 2024.03.11.

## Water Circulation in BC

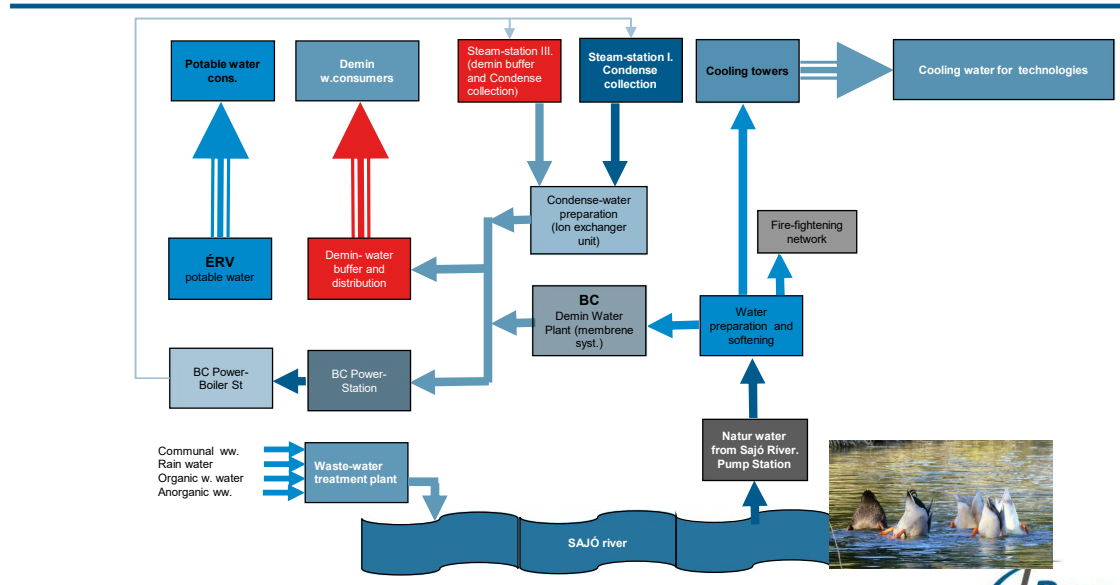
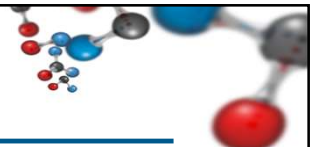

6



## The role of water in sustainability activities



### Targets:

- **Reduction of GHG-emission through Energy-efficiency measures**
  - Water usage as energy-transfer material: HOT (Steam; hot water), COLD (cooling water)
- **Reduction of water extracted from Sajó River by 10%**
  - Living with the Nature



## Water as a heat transfer material



**Steam:** High level heat technical process

**Waste heat:** lower heat level

### Waste heat Utilization:

- Heating buildings;
- Pre-heating of technological mediums, Redeeming fossil-heat;
- Absorption coolers – reducing electrical energy;
- Production of low-pressure steam;
  - Directly;
  - With heat-pumps.



## The importance of waste-heat recovery with the Amount of saved energy – In household figures



- At BorsodChem, various technological medias are cooled, heated in several areas. There are such medias that need to be heated, which we either heat or preheat using a technological medium – which may even be the medium itself – that needs to be cooled after another process.  
**We utilize the waste heat from steam condensation-water** as well. The amount of waste-heat utilized exceeds **1 million GJ** per year. By utilizing waste heat, we can simultaneously save electricity, cooling water, natural gas, and CO<sub>2</sub> emissions.
- Removing 1 million GJ of heat with an average wet-cooling tower requires nearly 8.000 MWh of electricity, which is equivalent to the annual electricity consumption of approximately **3.500 households**, and requires an additional 750.000 m<sup>3</sup> of make-up water, which is the annual water-consumption of **6.000 households**.
- Producing 1 million GJ of heat requires burning more than **30 million m<sup>3</sup> of natural gas**, which results in **60.000 t of CO<sub>2</sub>** emissions.
- 30 million m<sup>3</sup> of natural gas is equivalent to the annual heating-requirements of approximately **15.000 family homes**, and the use of natural gas for heating results in 4 tons of CO<sub>2</sub> emissions in a year.
- It can be said that increasing energy-efficiency or reducing the amount of energy used is directly or indirectly linked to reducing CO<sub>2</sub> emissions, which we show on every slide.



## Cooling and heating of technological media; Exploitation of synergies



- Example:** sulfuric-acid concentration, where heat extracted from the process medium and the utilization of waste heat from steam condensation are present simultaneously (first two steps).  
 This investment resulted in a total steam-energy saving of 5300 GJ/year compared to the previous situation. (*Waste-heat utilization already existed, but there was room for further improvement.*)  
 The amount of steam replaced would have been produced from 170.000 m<sup>3</sup> of natural gas - and this project resulted in a **reduction of ~320 t of CO<sub>2</sub> emissions!**
- The amount of **natural gas saved** is equivalent to the annual natural-gas **consumption of 75 households** for heating purposes.

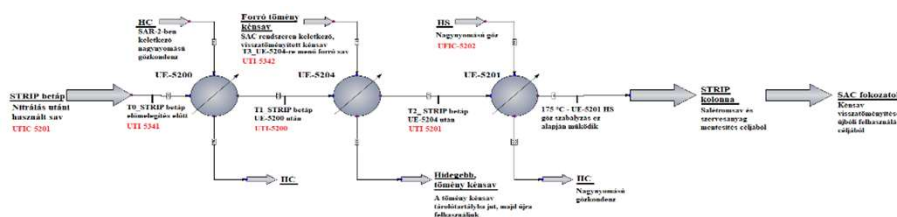

## Exploitation of synergies



Example: Production and preheating of industrial water using waste-heat: We preheat our industrial water in several stages according to its specific production or use.

In this production process, approximately 300.000 GJ of waste-heat is utilized, which is equivalent to the heat content of approximately 10 million m<sup>3</sup> of natural gas.

The reduction in CO<sub>2</sub> emissions is **19.000 t CO<sub>2</sub>**.



## Operation of absorption refrigerators: Electricity consumption; Water requirements and Reduction of greenhouse-gas emissions



### Absorption Coolers

Heat is used for cooling. This makes it an ideal solution for processes that generate waste-heat and also require cooling. It reduces cooling-requirements; electricity consumption and the use of make-up water in wet cooling-towers, which are typical in industry.

BorsodChem uses absorption coolers in its three plants with a total cooling-capacity of **15 MW** per hour. This results in approximately **21,5 MW** of heat removal per hour, which does not need to be removed by wet or dry coolers. By replacing compressor-cooling machines and reducing the electricity consumption of wet-cooling towers, the use of absorption-cooling machines results in annual electricity savings of 25.000 MWh.

The reduction in CO<sub>2</sub> emissions is also significant: 7.300 t CO<sub>2</sub>/year. However this reduction in emissions occurs indirectly during the production of electricity.

In addition, the reduction in supplementary water-demand results an annual ~ **250.000 m<sup>3</sup>** saving of industrial make-up water.

In a more understandable form:

- The total amount of electricity saved: 25.000 MWh, which is more than the annual electricity consumption of 10.000 families.
- The 250.000 m<sup>3</sup> of water is enough for more than 2.000 years for a family with a monthly consumption of 10 m<sup>3</sup>.
- A family emits 7.300 t CO<sub>2</sub> over 1.800 years.



## Domestic usage

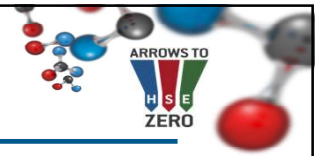

- A. We use the waste-heat from our steam condensers to heat our buildings; for ventilation and to produce hot water for domestic use.
- B. We provide heating for office-buildings; dressing rooms and community buildings with waste-heat throughout the heating season!  
In addition, 5.000 m<sup>3</sup> of domestic hot-water is produced annually thanks to waste-heat utilization!
- C. The amount of waste-heat utilized varies between 15.000 – 20.000 GJ per year, depending on the weather.
- D. The waste-heat used to heat our buildings is equivalent to 600.000 m<sup>3</sup> of natural-gas heat content and burning this amount of natural gas would result in the emission of nearly **1.200 tons of CO<sub>2</sub>**!
- E. The waste-heat used to heat our buildings is equivalent to the annual natural-gas consumption of approximately 300 households.



## Production of low-pressure steam using Waste-heat from flue gases



In some of our manufacturing processes BorsodChem uses natural-gas combustion to provide the necessary reaction-heat (decomposition-heat). The resulting flue gases still contain a significant amount of heat. By cooling them, the high-temperature heat can be utilized, which we use for steam production.

The amount of steam produced in this way reaches 140.000 tons per year.

This saves approximately 13.000.000 m<sup>3</sup> of natural gas, which is the annual natural-gas consumption of 5.900 moderately-modern family homes!  
This also **results in a reduction of 25.000 tons of CO<sub>2</sub> emissions.**

In the near future we plan to install a heat-pump technology, which not only produces steam from high-temperature media, but will be also capable of producing valuable steam from lower temperature-ranges.



## The role of water in sustainability activities



### Targets:

- Reduction of GHG-emission through Energy-efficiency measures
  - Water usage as energy-transfer material: HOT (Steam; hot water), COLD (cooling water)
- **Reduction of water extracted from Sajó River by 10%**
  - Living with the Nature



## BorsodChem Zrt. - KVO Waste-water Treatment



## BorsodChem Zrt. - KVO Waste-water Treatment

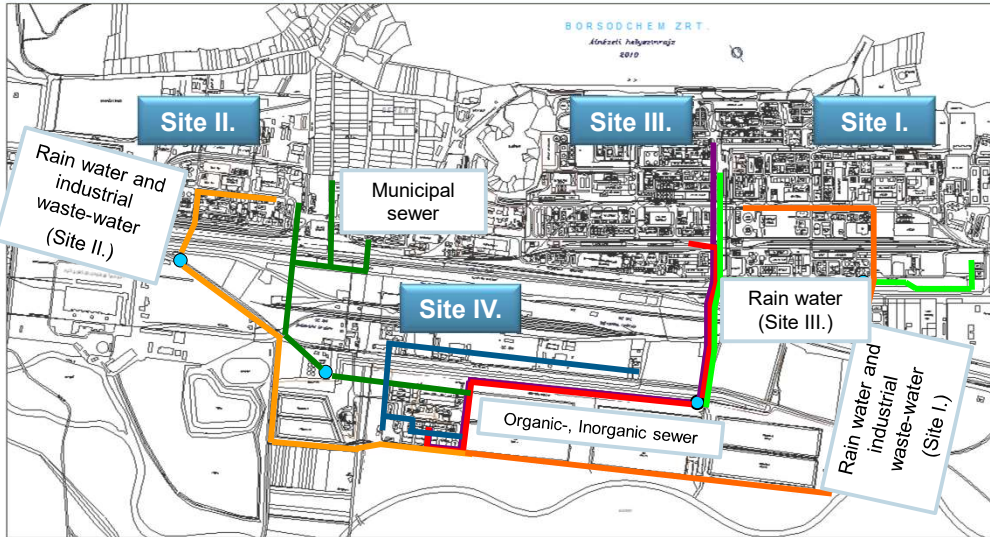

## Green Awards



In 2024, BorsodChem Zrt. was awarded the title of "**Green Company of the Year**" based on its submitted tender-project entitled: "*Coordination of recultivation and development processes from a sustainability perspective.*"

### The pillars of the Application:

- Coordination of recultivation and demolition projects (*Recultivation of saltwater pools; Integration of waste-disposal sites into the landscape; Construction of Plant IV, etc.*).
- LIFE Project (*Birdwatching; Tree planting etc.*).
- Replacement of building-material (*Access-road construction*).
- CO<sub>2</sub> saving.
- Reducing the burden on Residents.
- Regular status-assessment of the Sajó River.



**BorsodChem Zrt. - KVO**  
Increase of water-recycling

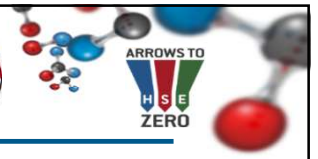

**Hundreds of thousands of m<sup>3</sup> of Sajó-River water is saved annually.**



**BorsodChem Zrt.**  
Introduction of LIFE project



**Target of Project:** Developing, testing and disseminating the partnership between the town and the Corporation.

The stakeholders collectively take action to reduce local climate-risks and take steps to strengthen climate adaptation.

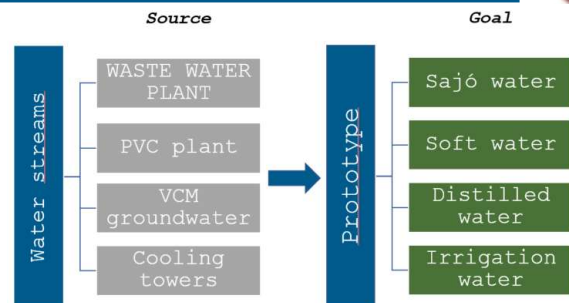

- The amount of water being extracted from Sajó River for industrial purposes can be reduced in the long term.
- The prototype facilitates the development of technological improvements aimed to improve BorsodChem's water-balance.
- **Target of the Equipment:** producing 1 m<sup>3</sup>/h clean water.



## Location of Sóstó ("Salty lagoon")



## Historical overview of BorsodChem Sóstó ("Salty lagoon") recultivation

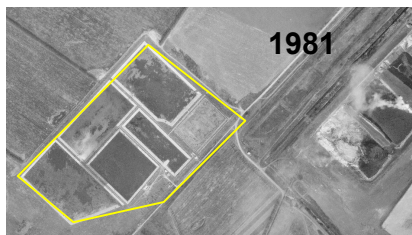

### Technical modifications from the 2000-s:

- Salt evaporator;
- Chlorine plant;
- VCM-1, VCM-2;
- MDI.

2017

- The discharge of salt water was ceased.
- Recultivation could begin.

1978

- Saltwater storage-tank system.
- Purpose: storage of high-salinity process water.

1994-1997

M1,M2,M5 pools: used appropriately to the era.

2015-2016

- Recultivation-conceptional plant. Pilot.
- Beginning of Consultations with the authorities.



## Historical overview of BorsodChem Sóstó ("Salty lagoon") recultivation



**2017**  
Beginning the  
Recultivation of Sóstó.



**2022**  
Formation of Sóstó aquatic  
habitats.



**2022-2024**  
Recultivation of  
M2, M5 pools.



**2015-2017**  
Recirculation of  
discharged salt-water.

**2018-2022**  
Recultivation of  
M1, M4, M6 pools.

**2024**  
Finishing the recultivation of  
Sóstó.

**2026**  
[Plan: Construction of a  
Solar Power-Plant in the  
area of Sóstó.](#)



## Demolition of buildings Reuse of raw materials from demolition



### Granuláló



### Polimer-1



Transportation of materials needed for recultivation  
was not done from the mines



Avoiding CO2 emissions  
from transport



Landfill  
On-site waste reuse



## Schematic illustration of cementation and packaging of sludge from pools.



Tens of thousands of tons of soil were needed for the recultivation of the area; which we executed in coordination with the construction of our Site IV area.

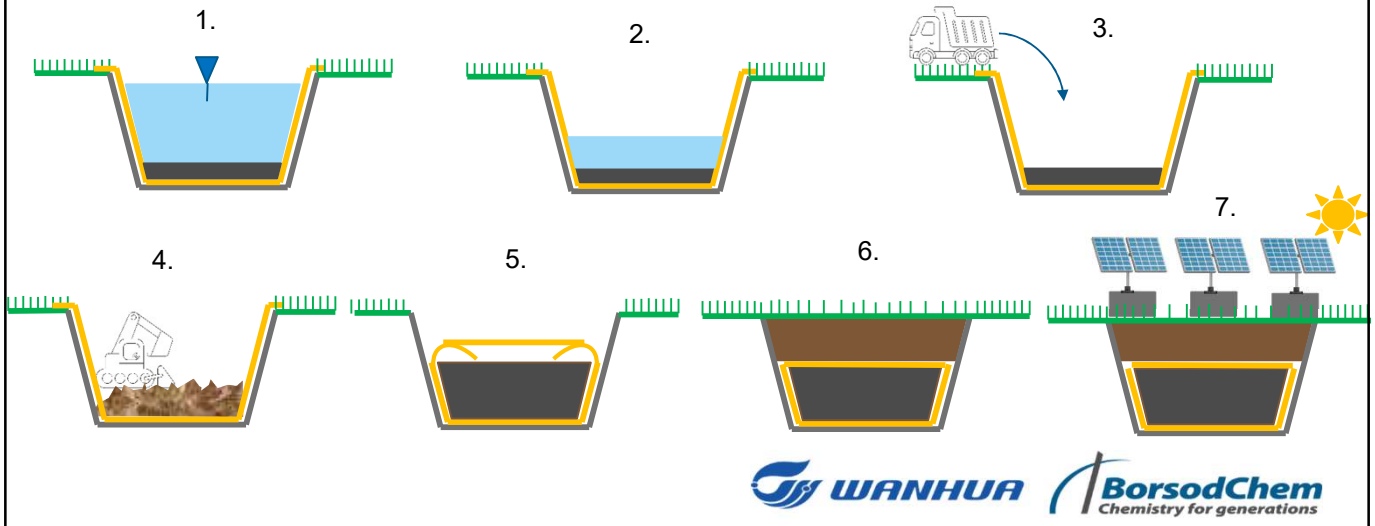

## M3 pool sludge-swap



When scheduling the work, we took into account the birds' nesting and rearing periods, so we only carried out the recultivation between 15. August and 31. March.



## Sóstó recultivation ("Salty lagoon")

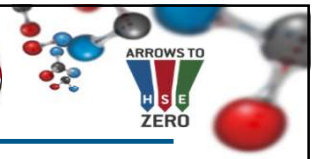

## BorsodChem Zrt. Nature conservation

Bird watching

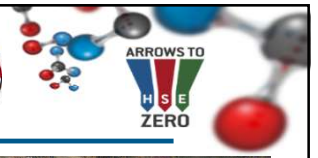

In cooperation with the Aggtelek National Park Directorate:

- Partially EU-funded LIFE climate adaptation project:
  - **Birdwatching tower** (for observing the birdlife of the M3 pool)
  - **Nature trail** (information boards)
- Goal:
  - **Maintaining wet habitats**
  - **Preserving bird habitats**
  - Preservation of **nesting sites for rare protected bird species**: gulipán, gólyatöcs, bölömbika and piroslábú cankó
  - **Preservation of biodiversity**: we converted the M3 and M4 basins into wetlands for migratory birds



## Summary of recultivation projects

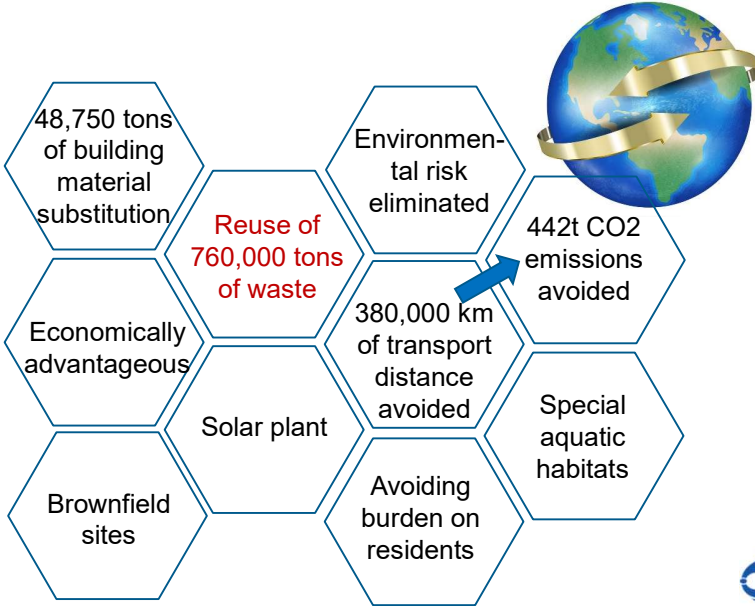
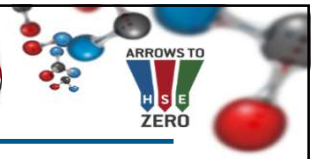

„People are responsible not only for what they do, but also for what they neglect to do,“

*(Protagoras, classical Greek philosopher, sophist thinker)*

**Thank you for your attention!**



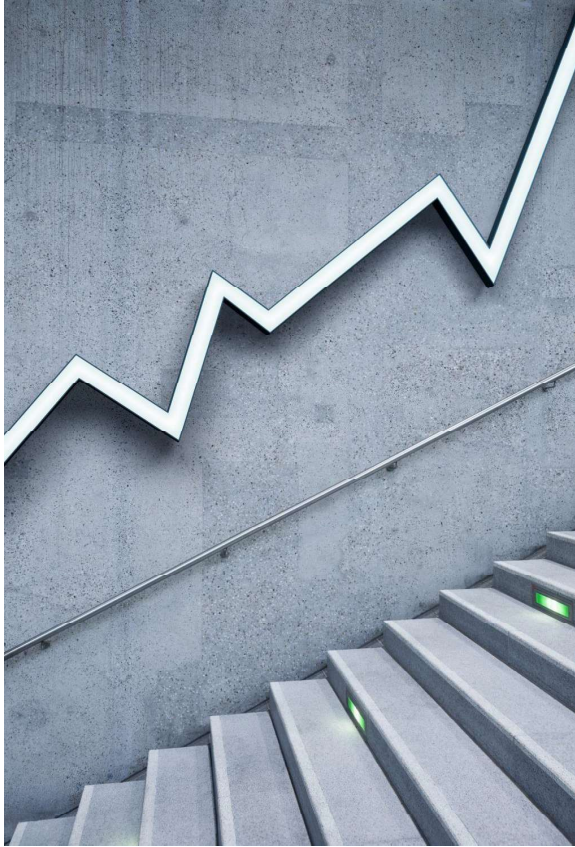

# EWFC

Waste management optimums  
-in reverse value chain engineering

26/08/2025 - MU

PETER GYORKOS | CEO | MWS | MOL GROUP

**MOL GROUP**



MOL GROUP IN BRIEF

INTEGRATED CENTRAL EUROPEAN MID-CAP OIL & GAS COMPANY

CORE ACTIVITIES



CLEAN CCS EBITDA BY SEGMENTS IN 2022 (USD MN)



KEY FIGURES

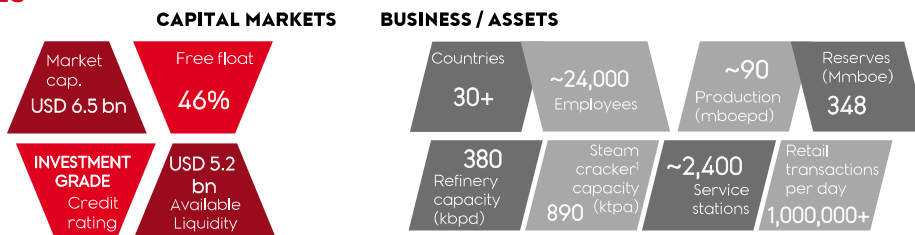

(1) Ethylene

MOL 2030+: PROFITABLY TOWARDS NET-ZERO  
ACCELERATED LOW-CARBON TRANSITION

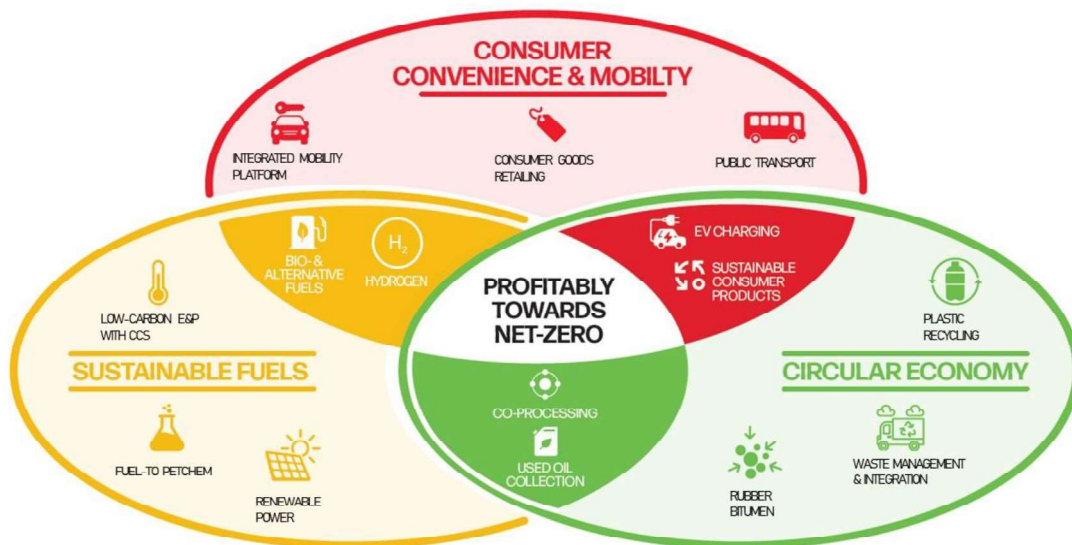



## MOL takes significant step towards expanding in circular economy

### HIGHLIGHTS OF THE AWARDED WASTE MANAGEMENT CONCESSION



#### BACKGROUND

- ▶ The Hungarian State **centralizes waste management and delegates the operation to the Concessor**
- ▶ Restructuring aims to **comply** with the **EU waste directives and targets**
- ▶ In order to reach the targets, waste management system needs improvements



#### OBJECTIVES

- ▶ **By 2025 50%** of municipal solid waste must be recycled
- ▶ **By 2040 min. 65%** of municipal solid waste must be recycled and **max. 10% landfilled**
- ▶ Waste management towards circular economy, development and optimization of the infrastructure



#### OPERATION

- ▶ Period: **35 years**
- ▶ Waste categories: municipal solid waste according to the **EU 2018/851 directive**
- ▶ Waste ownership: **The waste is the property of Concessor** from the waste status until recycling/treatment

# The concession is expected to cover ~5 mn tonnes of waste per year

AND THE WHOLE TERRITORY OF HUNGARY

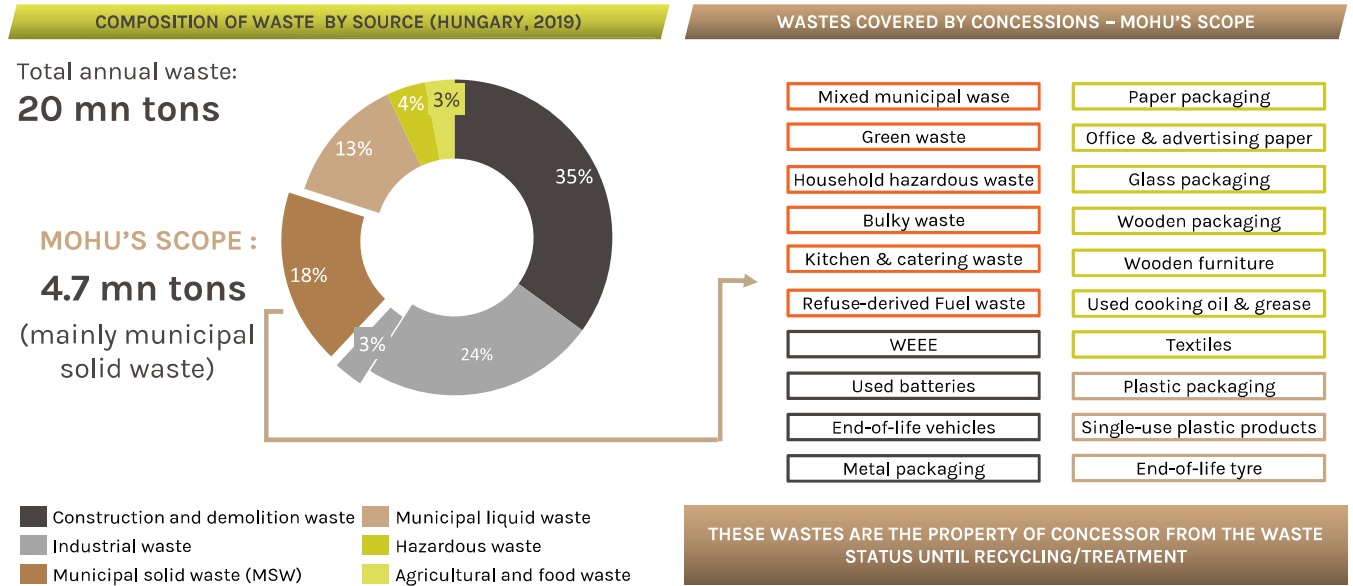

26/08/2025 - MU

Mechanical Metallurgy

Physical Metallurgy

**Extractive Metallurgy**



PyroMet

HydroMet

ElectroMet

2025, 08, 26,



**Laboratory Services**

- Accredited Laboratory
- Chemical Composition analysis
- Pre-treatment Advisory
- Extractive Metallurgy Advisory

**Waste management Services**

- Complex Waste Management
  - Concession waste (EoL)
  - Other and Production scrap
- Laboratory based invoicing
- Managing the whole VS
  - Collection
  - Logistics
  - Pre-treatment
  - Recycling
- ESG report
- Partner requirement First
  - Destruction
  - Partner and 3rd party audit

**Li-Ion Battery Logistics**

- Collection
  - Concession waste (EoL)
  - Other and Production scrap
- Logistics
- Storing
- Diagnose
- Second life
- Discharging

**Extractive Metallurgy**

- Lab analysis based technology chain for best method
  - PyroMet
  - HydroMet
  - ElectroMet
- Highest purity and yield
- Tailor-made products&services
- Own patented technology
- QA, QC, LabPlanning

**Sales, Procurement, Trading**

- Suppling customers based on
  - Own production
  - Waste owner collection
  - Procurement

2025, 08, 26,





# Waste management optimums -in reverse value chain engineering

Subtitle: Copper (Cu) & Precious Metals (PM) Recovery from e-Waste

Peter Gyorkos | CEO | MWS | MOL GROUP

## Metal streams

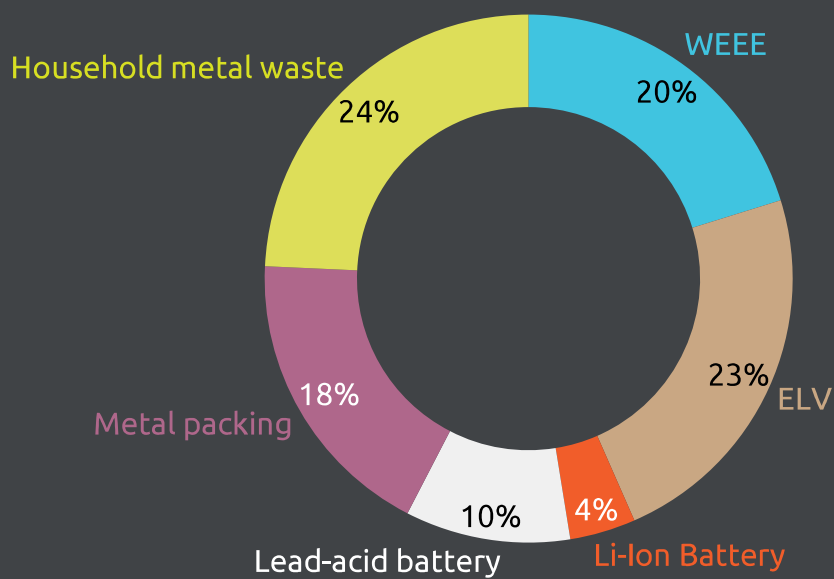

12 | MoHu strategy

# Metals in waste streams

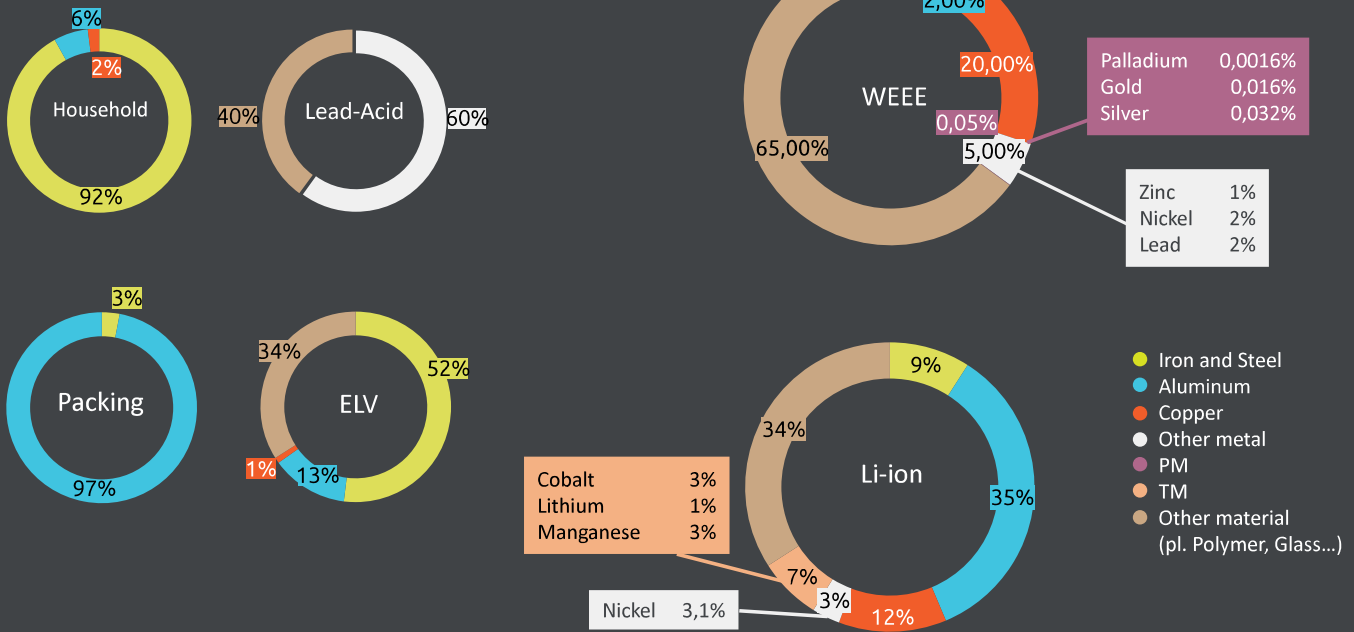

13 | MoHu strategy

**Journey of Selectivity in E-Waste Management**  
Purity vs. Cost vs. Value

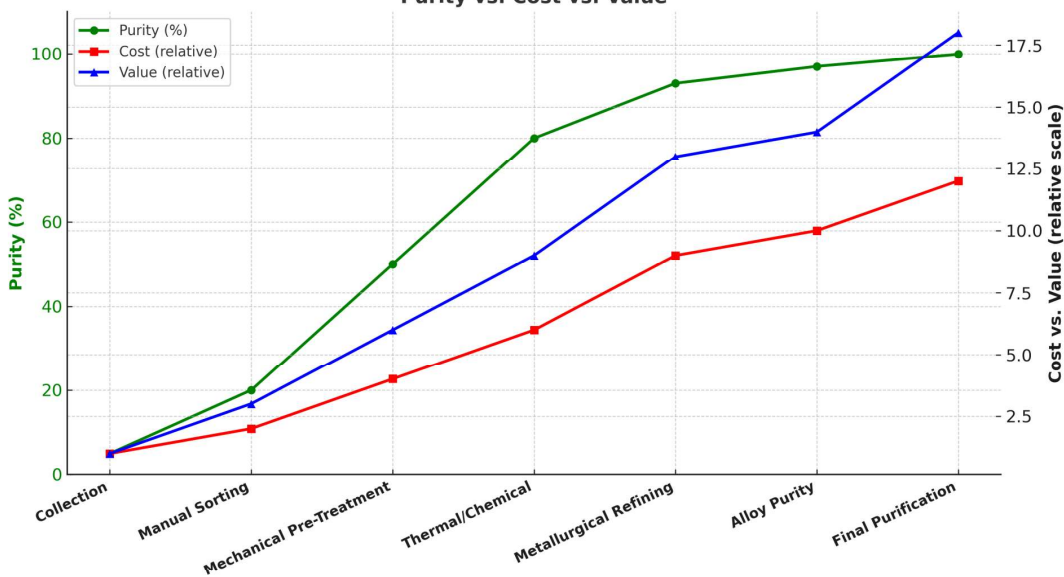

-The cleaner the better

Recovery Efficiency (Cu & PMs)

Cost-Benefit Analysis of E-Waste Recycling Methods

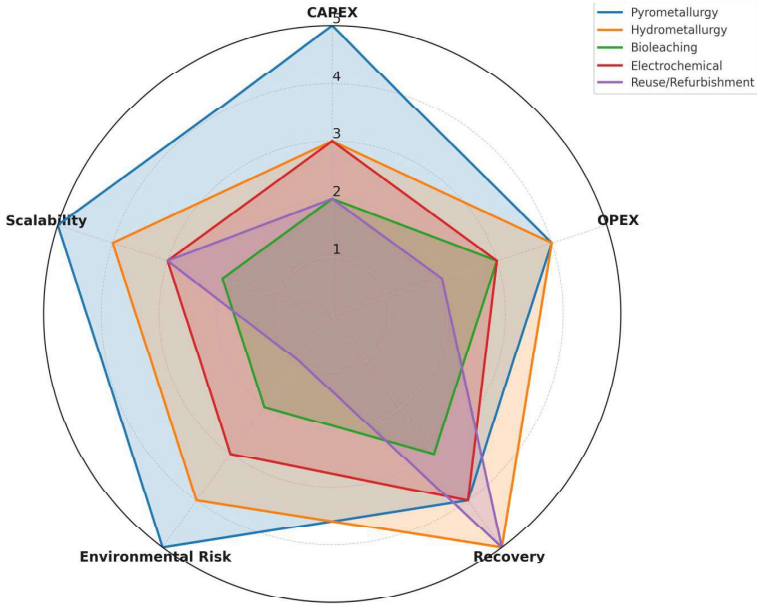

-Hydro&ElectroMet seems to be the best option at least in case of PM coating.

Recovery Efficiency (Cu & PMs)

Cost-Benefit Analysis of E-Waste Pre-Treatment Methods

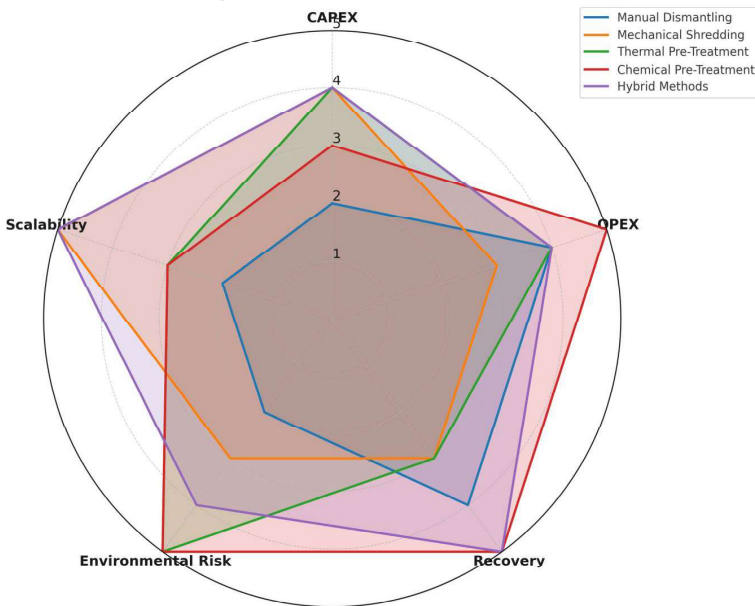

-Currently, for Cu&PM recovery, manual dismantling seems inevitable.

-Hybrid, purpose and waste material/fraction dedicated technology .

Shredding Dilemma: Particle Size vs Separators vs Capacity

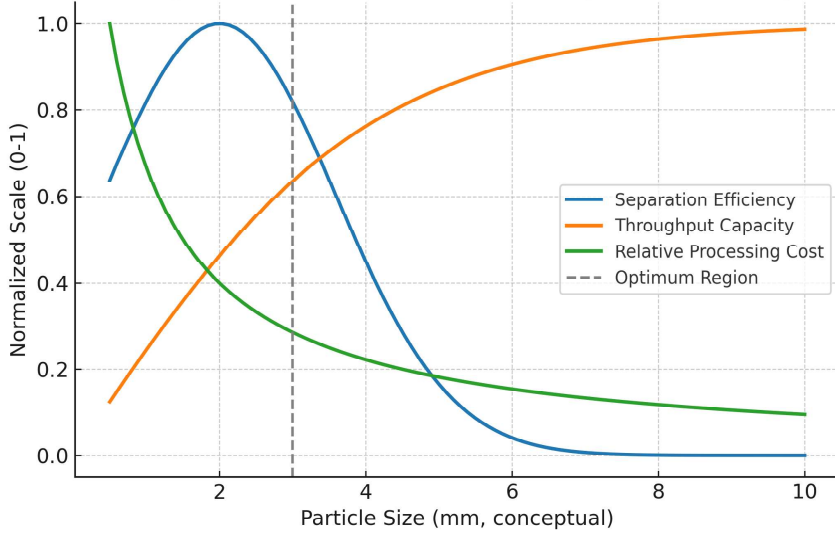

-For relatively high value fractions (eg. AlCu) smaller particle sizes, and simpler separation technology

-For iron&steel heavy fractions, free from Cu, higher 20-80mm particle size



2025, 08, 26.

Dilemma: Few Large Facilities vs Many Small Ones (Logistics vs OPEX vs Efficiency)

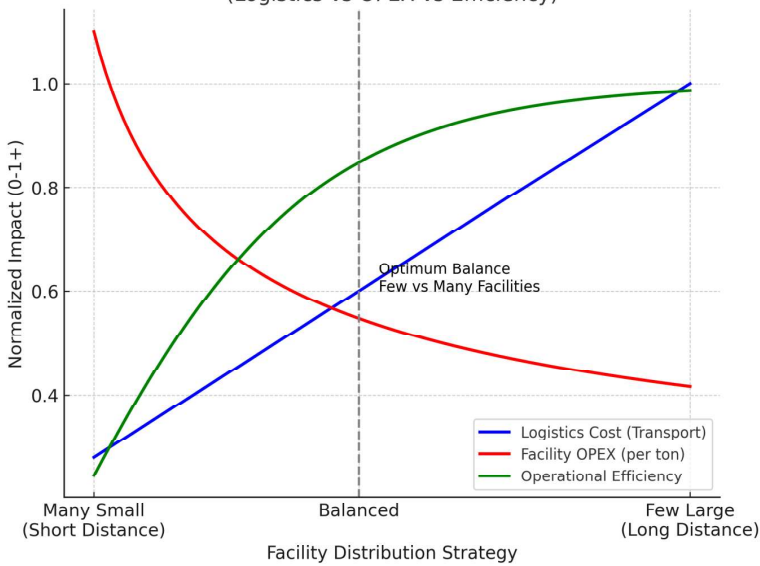

-Specialized pre-treatment results

- High cost
- High Recovery

-All-rounders result

- Low Recovery

What does Balanced mean?

1.) High value (Cu, PM, TM) and heterogeneous –specialized pre-treatment

3.) Low value and homogeneous –many smaller



2025, 08, 26.

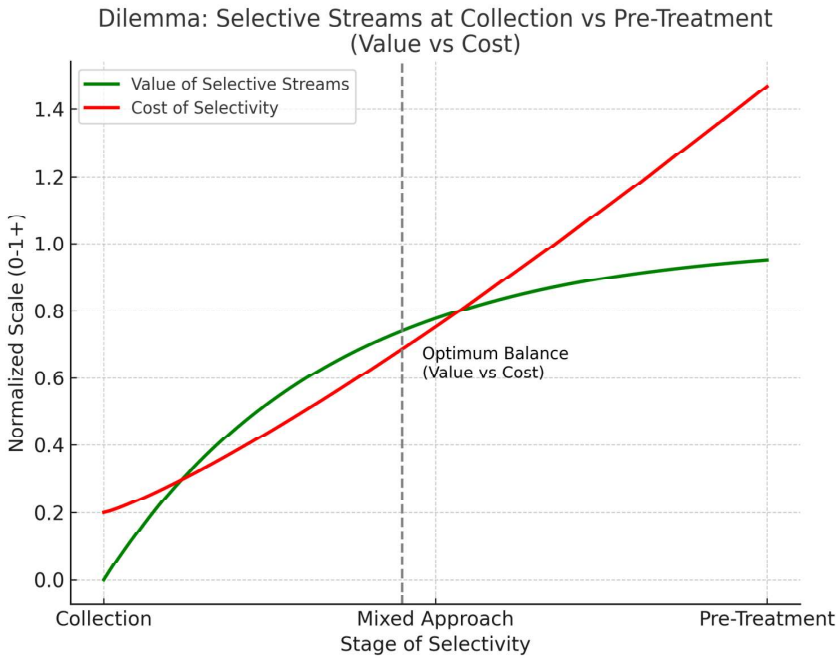

- More selective streams at collection result
  - High Logistics cost
  - High finance
  - High collection cost
  - High risk
  - High Recovery

- Less selective streams at collection result
  - Low Recovery

What does Mixed Approach mean?

- 1.) Exceptions
  - Producer Sales points (eg. GSM Shop, Apple store, ect.)
  - Specialized producers (eg. PCB, Connctor)
- 2.) High value (Cu, PM, TM) and heterogeneous -selective
- 3.) Low value and homogeneous -less selective
- 4.) DRS

**Evolution of Waste Separation Models:  
From Statistics → IoT → Digital Twin**

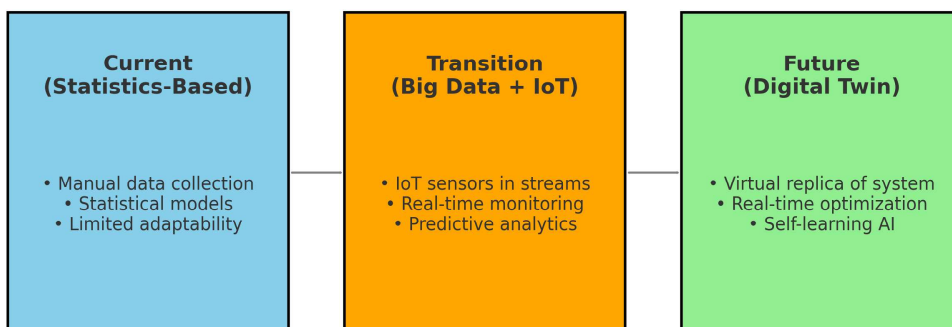

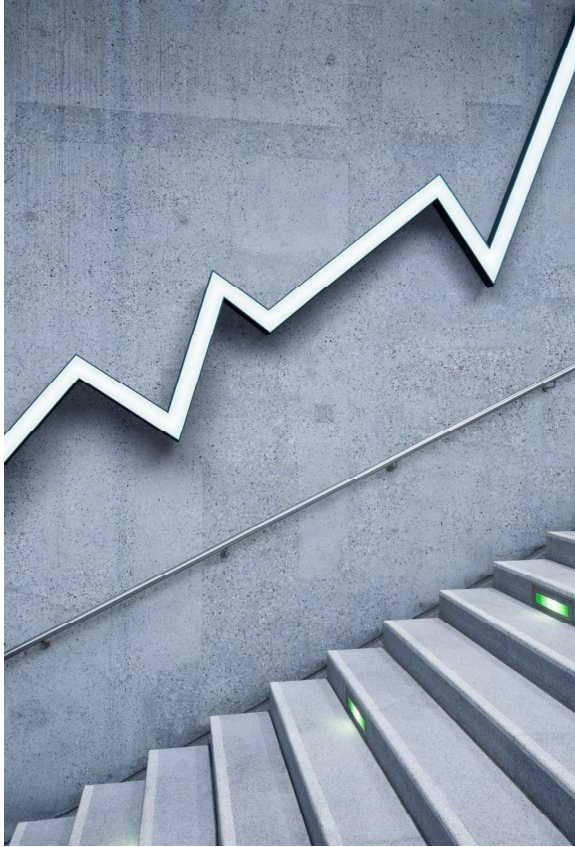

# Thank you

for your attention!

---

26/08/2025 - MU

PETER GYORKOS | CEO | MWS | MOL GROUP

WHAT WE WANT IS **POSSIBLE**



ENERGY WATER FOOD CLIMATE  
**NEXUS**  
INTERNATIONAL SUMMIT

**Microbial Bioagents at the Water-Soil Nexus: Bioremediation Strategies for Sustainable Resource Management in Mexico**



ITSCH



TECNOLÓGICO NACIONAL DE MÉXICO

Grisel Fierros Romero, Ph.D

## Mexico's Strategic Role in the W-E-F-C Nexus

### Mexico: A Living Laboratory for the Water-Energy-Food-Climate Nexus

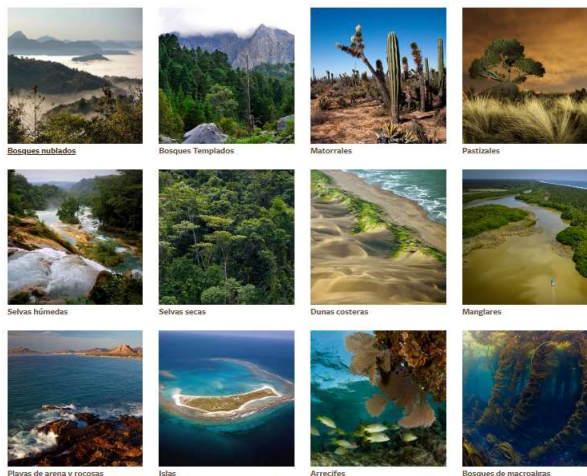

## Mexico's Nexus Challenge & Opportunity

- **Pressure Points:**

- **Water Stress:** Over 30% of territory faces water scarcity.
- **Energy Demand:** Growing population & industry increase pressure.
- **Food Security:** Ensuring nutrition.
- **Unique Opportunity:** This pressure creates a powerful incentive to develop integrated, Nexus-based solutions.



## Enhancing the Soil- Nexus: Phytoremediation of Arsenic & Cadmium using *Tagetes erecta* and Volcanic Microbes

- **Soil Pollution:** Arsenic (As) and Cadmium (Cd) are highly toxic, non-biodegradable heavy metals.
- **Nexus Impact:**
  - **Food:** Bioaccumulation in crops, entering the food chain.
  - **Water:** Leaching into groundwater resources.
  - **Land/Soil:** Soil health degradation, reduces productivity.



**Need: Sustainable, efficient, and low-cost remediation solutions.**

## The Proposed Solution: A Strategic Symbiosis

- **Core Strategy:** Combine the power of plants and microbes for enhanced remediation.
- **The Plant:** *Tagetes erecta* (Mexican Marigold).
  - Ornamental flower, native to Mexico.
  - Potential hyperaccumulator of metals (Cd, Cr, Pb)..
  - Rapid growth and extensive root system.
- **The Microbes:** Isolated from an extreme environment.
  - Sourced from the volcanic area of **Los Azufres, Michoacán**.
  - Naturally selected for high heavy metal resistance.



## Cempasúchil: The Flower of the Dead

- **Cultural Icon:**  
*Tagetes erecta*, known as **Cempasúchil** (from Nahuatl *cempōhualxōchitl*), is an enduring symbol of **Día de Muertos** (Day of the Dead) in Mexico.
- **Role in Tradition:**  
Families use them to create elaborate **pathways and altars (ofrendas)**
- **Deeper Meaning:**  
More than decoration, it represents the **cycle of life and death**, the sun's energy, and the fragile connection between two worlds.



## The Key Players: Metal-Resistant Microbes (LA1 & LA2)

- **Isolation:** Soil samples from Los Azufres, enriched with As and Cd.
- **Selection:** Two standout strains with exceptional resistance:
  - **LA1 (Bacterium):** MIC of **1800 ppm (24.0 mM/3120 mg/L)** for Arsenic and cadmium (3337mg/L/ 16.01mM)
  - **LA2 (Yeast):** MIC of **250 ppm** for Arsenic (**433 mg/L/3.33 mM**) and Cadmium (464 mg/L/ **2.23 mM**)
- **Characterization:** Resistance confirmed through growth curves under metal stress.

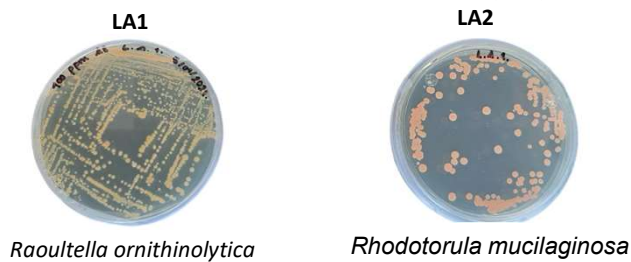

## The Symbiotic System: Plants + Microbes

- **Methodology:**
  - *In vitro* culture of *Tagetes erecta*.
  - Inoculation with microbes (LA1, LA2, or both) in media supplemented with As and Cd.
- **Hypothesis:** Microbial inoculation will enhance plant tolerance and growth under metal stress.

## Promising *In Vitro* Results

- **Visual Evidence:** Inoculated plants showed:
  - Greater root and shoot length.
  - Improved overall development compared to non-inoculated plants in metal-laden media.
- **Interpretation:** Microbes **LA1 and LA2** confer **greater tolerance** to As and Cd stress in *Tagetes erecta*, facilitating its establishment in contaminated soils.

## Plant-microbe interaction system *in vitro*

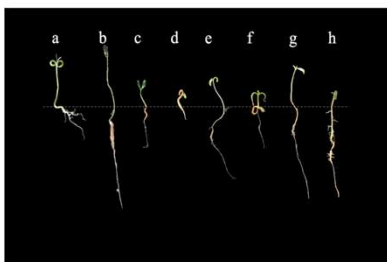

Fig. 10. Representative growth of *Tagetes erecta* inoculated with LA1.

Treatments are shown as follows: a) Control, b) Inoculation of LA1, c) As, d) As inoculated by LA1, e) Cd, f) Cd inoculated by LA1, g) As + Cd, h) As + Cd inoculated by LA1.

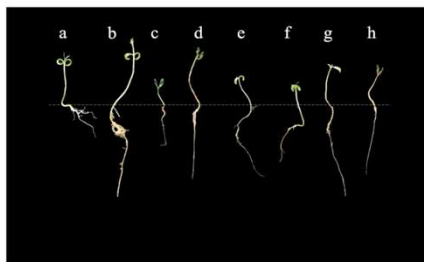

Fig. 11. Representative growth of *Tagetes erecta* inoculated with LA2.

Treatments are shown as follows: a) Control, b) Inoculation of LA2, c) As, d) As inoculated by LA2, e) Cd, f) Cd inoculated by LA2, g) As + Cd, h) As + Cd inoculated by LA2.

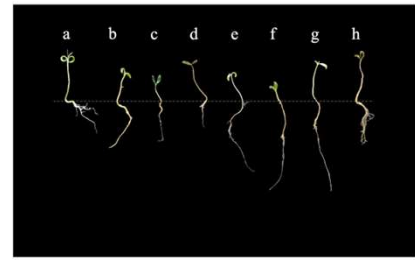

Figure 12. Representative growth of *Tagetes erecta* inoculated with LA1 & LA2.

Treatments are shown as follows: a) Control, b) Inoculation of both microorganisms, c) As, d) As inoculated by both microorganisms, e) Cd, f) Cd inoculated by both microorganisms, g) As + Cd, h) As + Cd inoculated by both microorganisms.

## Scaling the System: Microcosm Experiment

- The system was transferred to microcosms (pots) with artificially contaminated substrate.
- **Objective:** To simulate more realistic *ex situ* remediation conditions and quantify metal extraction.
- **Analysis:** Substrate and plant tissue samples sent for metal quantification via **ICP-OES**.



Fig. 13. Microcosm establishment representation.

## Scaling the System: Microcosm Experiment

- A successful enhanced phytoremediation system should achieve **significant metal removal (>70%)** in a growing cycle,
- Our *in vitro* results demonstrate a strong plant-microbe synergy under metal stress. Projecting this to a full-scale microcosm.



Fig. 13. Microcosm establishment representation.

## A Promising Nexus Solution

- This plant-microbe system is projected to be **highly effective**, successfully reducing heavy metal concentrations below national regulatory limits in a single cycle.
- **The synergy between *T. erecta* and the microbial consortia (LA1 & LA2) is the key driver for this efficient remediation.**
- **This represents a sustainable, low-energy, and cost-effective technology for restoring polluted soils, directly contributing to Food Security and Water Quality within the Nexus framework.**

## Relevance to the Nexus & Conclusions

- **Nexus Connection:**
  - **Land Recovery:** Enables safe reuse of soil for agriculture (**Food**).
  - **Pollution Prevention:** Prevents leaching of metals into groundwater (**Water**).
  - **Sustainable Technology:** Low energy consumption compared to physico-chemical methods (**Energy**).
- **Conclusion:** Inoculating *Tagetes erecta* with metal-tolerant microbes from extreme environments is a **highly promising, sustainable strategy**, aligned with the **Nexus framework**, for the bioremediation of polluted soils.

# Köszönöm/Thank you/ Gracias

## Acknowledgments

- **To Dr. Victor Ibeanusi:**  
Thank you for inviting me to this important Nexus project.
- **To Dr. Ashutosh Sharma:**  
My gratitude for your support at the Bioengineering Center in Querétaro.



WHAT WE WANT IS  
**POSSIBLE**



ENERGY WATER FOOD CLIMATE  
**NEXUS** México  
INTERNATIONAL SUMMIT



**2026 Morelia, Michoacán at the Instituto Tecnológico Superior de Ciudad Hidalgo (TecNM)**



UNESCO World Heritage Site



## Mobilising resources and partnerships for transdisciplinary impact: Strengthening the Energy-Water-Food-Climate Nexus at Historically Disadvantaged Institutions

**Mbali Mkhize (Senior Director: Marketing & Communications)**  
**Zama Sishi (Director: Stakeholder Relations Management)**

1

## ABOUT MUT



One of the six universities of technology in the Republic of South Africa.

Located in Umlazi Township with a population of over 400K.

Named after our founder Prince Mangosuthu Buthelezi, who sadly passed away on 09 September 2023.

In 1979 Mangosuthu Technikon opened its doors to its first fifteen students.

Currently a total population of about 14,500 students with a gender parity of 50/50.  
+-60 000 alumni

The three faculties: Engineering, Management Sciences, and Applied and Health Sciences are each led by a Dean

2

## Research Focus Areas (RFAs)

- Research Focus Areas known as **Areas of Collaborative Academic Excellence (ACAEs)**, which align with the **Framework for the Science Technology & Innovation Decadal Plan**

### MUT Areas of Collaborative Academic Excellence (ACAEs)

Energy and Environment	Health and Food Security	Human and Social Settlements and Development
Clean Water Renewable Energy	Traditional medicine Agriculture Public Health Food security	Informal Settlements Sustainable living

3

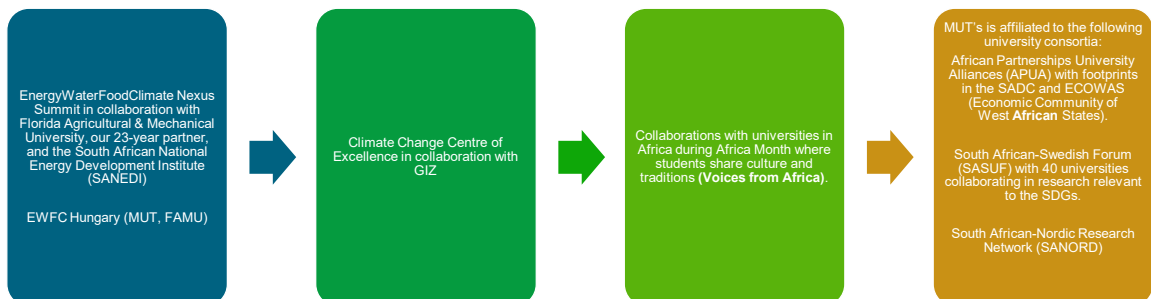

4

## Analysis for MUT-FAMU's partnership model since 2000

### TEN GUIDING PRINCIPLES



Mutual Respect



Reciprocity



Shared Decision-Making



Co-creation of Knowledge



Fair Resource Allocation



Transparency



Sustainability



Capacity Strengthening



Voice & Representation



Ethical Engagement

5



## Towards truly transformative partnerships

What has been the bedrock of our partnership with FAMU and SANEDI

6

## Equity is not an add-on—it must shape the foundation

### Guide

Equity must guide all aspects of partnership design, from agenda-setting to resource allocation.

### Be

Historically disadvantaged institutions must be seen not as recipients, but as co-leaders and knowledge producers.

### Avoid

Avoid extractive models that reinforce global North-South hierarchies

7

## A true partnership requires humility, listening, and rethinking power

### True

True collaboration demands shared ownership, not dominance.

### Listen

Institutions must listen before leading, respecting community knowledge, local expertise, and lived experience.

### Rethink

Rethink traditional metrics of “capacity” and “expertise”—value diverse contributions equally.

8

## Our challenge: build new systems, not replicate the old



Transdisciplinary work means disrupting silos, not reinforcing academic or institutional boundaries.



Instead of slotting new initiatives into outdated structures, we must design inclusive, responsive, and adaptable systems.



Transformation means redesign, not replication—especially for institutions historically excluded from power and funding networks.

9



## The EWFC Nexus and its strategic relevance

10

Global relevance: The EWFC Nexus is embedded in many Sustainable Development Goals (SDGs):



**SDG 2: ZERO HUNGER**



**SDG 6: CLEAN WATER AND SANITATION**



**SDG 7: AFFORDABLE AND CLEAN ENERGY**



**SDG 13: CLIMATE ACTION**

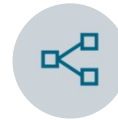

**SDG 17: PARTNERSHIPS FOR THE GOALS**

11

## African Context – Agenda 2063

- The African Union’s **Agenda 2063**, particularly **Aspiration 1** (“A prosperous Africa based on inclusive growth and sustainable development”), aligns with the Nexus model. It emphasises:
  - Climate-resilient agriculture
  - Water security
  - Universal energy access
  - Green industrialisation
  - In many African countries, the challenges of food insecurity, unreliable energy access, and climate vulnerability co-exist. The Nexus approach provides a framework to co-address these challenges through coordinated, cross-sectoral planning.

12

## The EWFC Nexus and its strategic relevance

South Africa's National Development Plan (NDP) 2030:

- Chapter 5: Transition to a low-carbon economy
- Chapter 6: An integrated and inclusive rural economy
- These chapters reflect a Nexus-oriented mindset, calling for climate-smart development, sustainable resource use, and inclusive rural innovation.
- Institutions like MUT have a key role in localising these goals.

13



### Strategic relevance for universities (Especially Historically Disadvantaged Ones)

#### Knowledge and Innovation Hubs

Universities like MUT can serve as regional innovation nodes, co-creating solutions with communities, governments, and industries.

Transdisciplinary research anchored in the Nexus can inform policy, curriculum, and community impact projects.

14



## Strategic relevance for Universities (Especially Historically Disadvantaged Ones)

- **Funding and Partnerships**
- Donors, governments, and global development institutions increasingly prioritize **integrated approaches**.
- Nexus-aligned projects are more likely to attract funding from entities like GIZ, SANEDI, UNEP, and the Green Climate Fund.

15



## Resource Mobilisation Lab

How do we keep the EWFC relevant, fluid, and sustainable?

- a. Joint curriculum development-COIL
- b. Collaborative research proposals
- c. Building international academic networks
  - Women in Climate Change
  - Deans' Forum
  - Senior Lecturers' Forum
  - Internationalisation offices

16



Questions?

17



EXCELLENCE IN RESEARCH, INNOVATION AND ENGAGEMENT

EXCELLENCE IN COMMUNITY ENGAGEMENT

EXCELLENCE IN TEACHING AND LEARNING

TO CREATE AN ENABLING SUPPORT ENVIRONMENT

TARGETED NATIONAL AND INTERNATIONAL ENGAGEMENT

MUT  
MANGOSUTHU  
UNIVERSITY OF TECHNOLOGY  
www.mut.ac.za

The image features the MUT logo on the left, which consists of a stylized graphic of a curved line and a zigzag pattern with colored diamonds, followed by the text 'MUT MANGOSUTHU UNIVERSITY OF TECHNOLOGY'. To the right is a large graphic of a stylized arrow pointing up and to the right, composed of several overlapping geometric shapes in shades of red, blue, and yellow. The text in the center reads: 

**REORIENTING INNOVATION FOR INCLUSIVE ECONOMIC GROWTH IN SOUTH AFRICA:  
*Achieving the Sustainable Development Goal***

**NEXUS INTERNATIONAL SUMMIT,  
WEDNESDAY, 26-28 AUGUST 2025**

**UNIVERSITY OF MISKOLC, HUNGARY**

**DR MANDLA HLONGWANE**

## Table of Contents

1. Introduction
2. The Case for a new Science Enterprise Model
3. Key Components of the Science Enterprise Model
4. Addressing Systemic Barriers
5. Case Reflection from the South African Context
6. Alignment with Continental Development Goals
7. Policy Recommendations
8. Conclusion

shape and own the future

MUT MANGOSUTHU  
UNIVERSITY OF TECHNOLOGY

## Introduction

- **Africa at a Critical Juncture**
  - Innovation driven by science & technology can catalyze transformative development.
  - The continent has immense intellectual capital and growing network of universities, research institutions, and innovation hubs.
  - However, the conversion of knowledge into socio-economic impact remains limited.
  - A reimagined science enterprise model is needed – embedding commercialisation, inclusive innovation, and entrepreneurship at the core.
  - By leveraging science enterprise as a strategic lever, Africa can accelerate its journey towards knowledge-based economies and inclusive development.

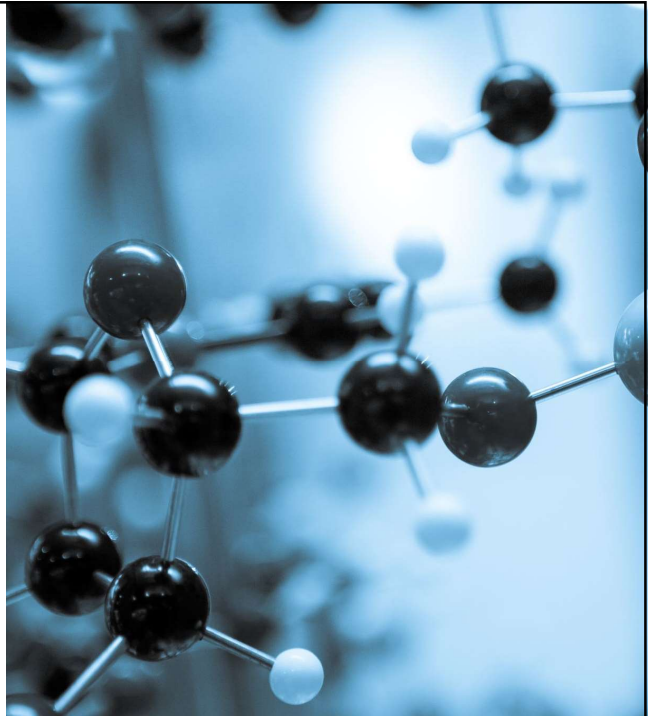

## The Case for a New Science Enterprise Model

### Rethinking Research & Innovation

- Traditional focus: publication & citations
- Limitation: less emphasis on real-world application
- Need: balance academic output with societal impact

### The Science Enterprise Model

- **Broadens institutional goals beyond academia looking at the key areas:**
  - Innovation Commercialisation
  - Interdisciplinary collaboration
  - Entrepreneurship development
  - Community engagement

## The Case for a New Science Enterprise Models

Transforms universities & Research Institutes (CSIR, ARC, SAMRC)

Knowledge – Startups, industries, policies, and community solutions

Positioning institution as engines of societal transformation

# Key Components of the Science Enterprise Model

## Institutional Innovation Ecosystem

- Technology Transfer Office – Intellectual Property
- Innovation Hubs & Incubation Centers
- Interdisciplinary research with commercial potential

## Entrepreneurial Training and Culture

- Shift in academic culture is necessary
- Entrepreneurial skills (Researchers and students)
- Structured programs for entrepreneurship
- Design thinking
- Hackathons
- Makerthon

# Key Components of the Science Enterprise Model

- Industry Linkages



## Addressing Systemic Barriers

- **While promising models exist, systemic challenges persist. This include:**
  - Fragmented innovation governance structures
  - Limited funding for proof-of-concept and prototyping
  - Insufficient capacity in IP management and Commercialisation
  - Weak integration between academic research and national development priorities



## Case Reflections from South African Context

### Valuable lessons in building a science enterprise system

Government –led programs such as Technology Innovation Agency (TIA)	National Intellectual Property Management Office (NIPMO) – IPR Act No.58 of 2008 – support commercialisation of Research.	University progressively establishing TTOs, and several innovation competitions.	MUT – recent established TTO to uncover untapped IP
---	---	--	---



Resulting in new disclosures and enterprise development opportunities.

## Alignment with the Continental Development Goals

---

- Linking the Science enterprise model with the Sustainable Development Goals (SDGs) or Agenda 2063: the proposed model inherently supports:
  - Human capital development
  - Technology self-reliance
  - Industry diversification
  - Community based innovation

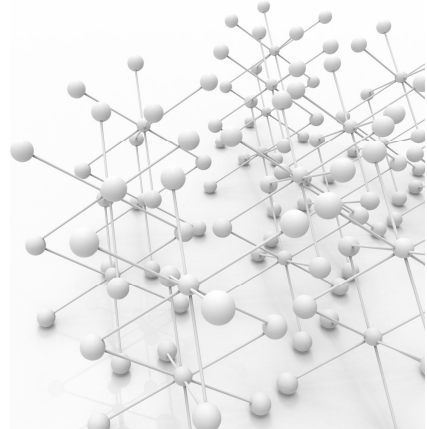

## Policy Recommendations

---

- **To operationalize the new science enterprise model, the following actions are recommended:**
  - Integrate commercialization and entrepreneurship training into academic programs across all disciplines.
  - Strengthen institutional support structures, including TTOs, innovation offices, and incubators.
  - Facilitate cross-sector partnerships to co-fund and co-develop research outputs.
  - Provide targeted funding for early-stage innovation development (e.g., prototyping, IP protection).
  - Create performance metrics for universities that include innovation and enterprise impact.

## Conclusion

Science enterprise offers a pragmatic and transformative pathway for African development.

Create solutions that matter

Bridging knowledge with impact and turning Africa's ideas into assets

"Creativity is thinking up new things. Innovation is doing new things." – Theodore Levitt

**THANK YOU**



The image features the MUT logo on the left, with the text 'MUT MANGOSUTHU UNIVERSITY OF TECHNOLOGY'. To the right of the logo is the title of the event: **Green Entrepreneurship in the Circular Economy: Unlocking Opportunities for SMEs in Driving Sustainable Innovation**. Below the title is the location and date: **2025 NEXUS Summit, University of Miskolc, Hungary** and **Date: 27 August 2025**. At the bottom left, the name **Dr Melvin Sello Mothoa** is listed. The background includes decorative geometric shapes in yellow, red, and blue.

## Background and Introduction

The 21st century is defined by interconnected challenges such as climate change, rising inequality, and unsustainable patterns of economic growth.

- Traditional linear economic systems – destructive and socially limiting
- Shift towards circular economy – provides regenerative approach, resource efficiency, reuse, recycling and innovation-led development.

This transformation caters for SMMEs – they are embedded in communities, and capable of driving grassroots innovation.

SME contribution are critical in addressing United Nations Sustainable Development Goals (SDGs), the African Union's Agenda 2063, and the United Nations Development Programme's (UNDP) mandate for inclusive and sustainable growth

Green Entrepreneurship in the Circular Economy: Unlocking Opportunities for SMEs in Driving Sustainable Innovation

**MUT** MANGOSUTHU  
UNIVERSITY OF TECHNOLOGY

## Objectives of the study

### Objectives:

- To examine how green entrepreneurship anchored in circular economy principles can drive sustainable innovation.
- To explore the role of SMEs in advancing the Sustainable Development Goals (SDGs), Africa's Agenda 2063, and UNDP development priorities.
- To identify the ecosystem enablers (policy, finance, technology, and consumer behavior) that support SME participation in circular practices.
- To provide actionable recommendations for policymakers, development agencies, and investors.

### Research Question:

How can SMEs, through green entrepreneurship and circular economy practices, be empowered to contribute effectively to global and continental sustainability frameworks such as the SDGs, Agenda 2063, and the UNDP's development agenda?

Green Entrepreneurship in the Circular Economy: Unlocking Opportunities for SMEs in Driving Sustainable Innovation

**MUT** MANGOSUTHU  
UNIVERSITY OF TECHNOLOGY

## Literature review of the study

The concept of the circular economy (CE) has gained global attention as a transformative alternative to the linear “take, make, dispose” model. (Ellen MacArthur Foundation 2015)

**Circular Economy:** does not only drive resource efficiency but also creates innovation opportunities

- Regenerative design, reuse, recycling
- Business models that are product as a service and Closed-loop supply chains

**Green Entrepreneurship:** complements this transition by integrating profitability with social and environmental missions

- Profit + environmental & social value

**Enabling Ecosystems:** An enabling ecosystem for green entrepreneurship consists of supportive policies

- Finance: impact investing, green funds
- Technology: AI, IoT, blockchain
- Market & consumer awareness

Green Entrepreneurship in the Circular Economy: Unlocking Opportunities for SMEs in Driving Sustainable Innovation

**MUT** MANGOSUTHU  
UNIVERSITY OF TECHNOLOGY

## Research Methodology

A qualitative systematic review approach to explore the intersection of **green entrepreneurship**, circular economy practices, and sustainable development frameworks.

<b>Method/Approach</b>	Qualitative meta-synthesis
<b>Data Collection</b>	systematic review of 25 documents published between 2015 and 2024. These included peer-reviewed journal articles, institutional case reports, and policy frameworks.
<b>Analysis</b>	Thematic analysis via NVivo
<b>Focus</b>	SMEs in emerging economies (esp. Africa)

Green Entrepreneurship in the Circular Economy: Unlocking Opportunities for SMEs in Driving Sustainable Innovation

**MUT** MANGOSUTHU  
UNIVERSITY OF TECHNOLOGY

## Key Findings

### **Strategic Convergence:**

Green entrepreneurship and circular economy practices directly align with the SDGs (8, 9, 12, 13) and Agenda 2063 (Aspirations 1 & 6), reinforcing their role in promoting inclusive growth, innovation, responsible production, and climate action.

### **SME Potential:**

SMEs, due to their agility and community integration, are well-positioned to act as catalysts of sustainable innovation by adopting circular business models such as product-as-a-service, reverse logistics, and upcycling.

### **Ecosystem Enablers:**

Supportive policies, green financing instruments, and technological tools (AI, IoT, blockchain) are critical for SMEs to successfully transition to circular practices.

### **UNDP's Strategic Role:**

The UNDP fosters capacity building through incubators, funding mechanisms, SDG-alignment tools, and accelerator labs, helping to scale green entrepreneurship in resource-constrained settings.

Green Entrepreneurship in the Circular Economy: Unlocking Opportunities for SMEs in Driving Sustainable Innovation

**MUT** MANGOSUTHU  
UNIVERSITY OF TECHNOLOGY

## Case Studies

- RecyclePoints (Nigeria): recycling rewards → green jobs  
[https://socialbusinessdesign.org/recyclepoints-business-model-case-study/?utm\\_source=chatgpt.com](https://socialbusinessdesign.org/recyclepoints-business-model-case-study/?utm_source=chatgpt.com)
- MyGug (Ireland): food waste → biogas (cooking & Fertilizers)  
<https://amugreen.com/mygug-for-communities/>
- Greenbelt Movement (Kenya): women/youth eco-enterprises (Planting Trees – environment restoration)  
<https://journeys.dartmouth.edu/envs3rmatsumoto/envisioning-the-future-2/the-green-belt-movement-a-case-study/>

Green Entrepreneurship in the Circular Economy: Unlocking Opportunities for SMEs in Driving Sustainable Innovation

**MUT** MANGOSUTHU  
UNIVERSITY OF TECHNOLOGY

## Conclusion & Call to Action

The study concludes that green entrepreneurship, grounded in **circular economy** principles, offers a powerful pathway for achieving **sustainable development** goals. **SMEs** can play a **transformative** role in creating green jobs, reducing waste, and driving innovation, particularly in emerging economies. Their success, however, relies on supportive policies, access to finance, technology adoption, and consumer awareness. Case studies show that when adequately supported, SMEs can **turn environmental challenges** into **inclusive economic** opportunities. Africa, in particular, has the potential to lead in green growth if multi-stakeholder collaboration is strengthened.

Green Entrepreneurship in the Circular Economy: Unlocking Opportunities for SMEs in Driving Sustainable Innovation

**MUT** MANGOSUTHU  
UNIVERSITY OF TECHNOLOGY

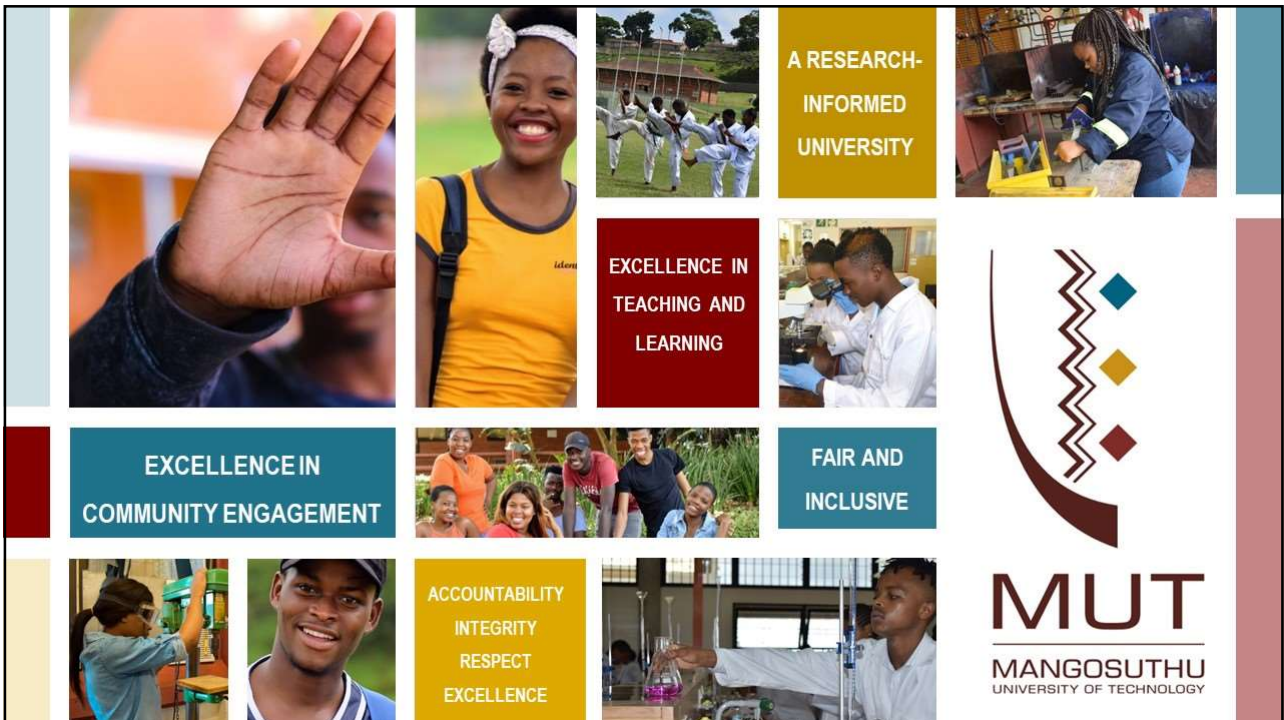



# Circularity in Business or Business in Circularity?

Zita Szederkényi  
Miskolc, August 27th, 2025



## BCSDH in brief



### Vision

To create a world where more than 9 billion people are all living well and within planetary boundaries, by 2050.



**154**  
member  
companies



**40%** of the  
Hungarian GDP  
generated by the  
members

### Mission

To accelerate the transition to a sustainable world by making more sustainable businesses more successful.





Member of the  
**WBCSD**  
**Global Network**



## European Circular Economy Hotspot



The Hotspot is an annual event, which has grown from a gathering first held in the Netherlands in 2016. It is held in a different location every year, with each host region chosen for demonstrating international best practice and innovation in the development of a circular economy.

<h3>VIP Reception</h3> <p>6 October 2026</p>  <ul style="list-style-type: none"> <li>Hotspot winner announced</li> <li>VIP reception</li> <li>Networking</li> </ul>	<h3>Conference and Gala Dinner</h3> <p>7 October 2026</p>  <ul style="list-style-type: none"> <li>Plenary</li> <li>Seminars</li> <li>Gala dinner</li> <li>Networking</li> </ul>	<h3>Site Visits</h3> <p>8 October 2026</p>  <ul style="list-style-type: none"> <li>6-8 venues</li> <li>Site visits (best practices)</li> </ul>
--	--	---



Join at [menti.com](https://www.menti.com) | use code **4884 2655** Mentimeter

## Instructions

Go to  
**[www.menti.com](https://www.menti.com)**

Enter the code  
**4884 2655**



Or use QR code

👍 🐦 ❤️ ? 🗳️

## Mentimeter



You are 20 y/o today, if production remains static, how old will you be when...

- ...there's no more oil in the world?
- ...there's no more coal in the world?
- ...there's no more lead in the world?

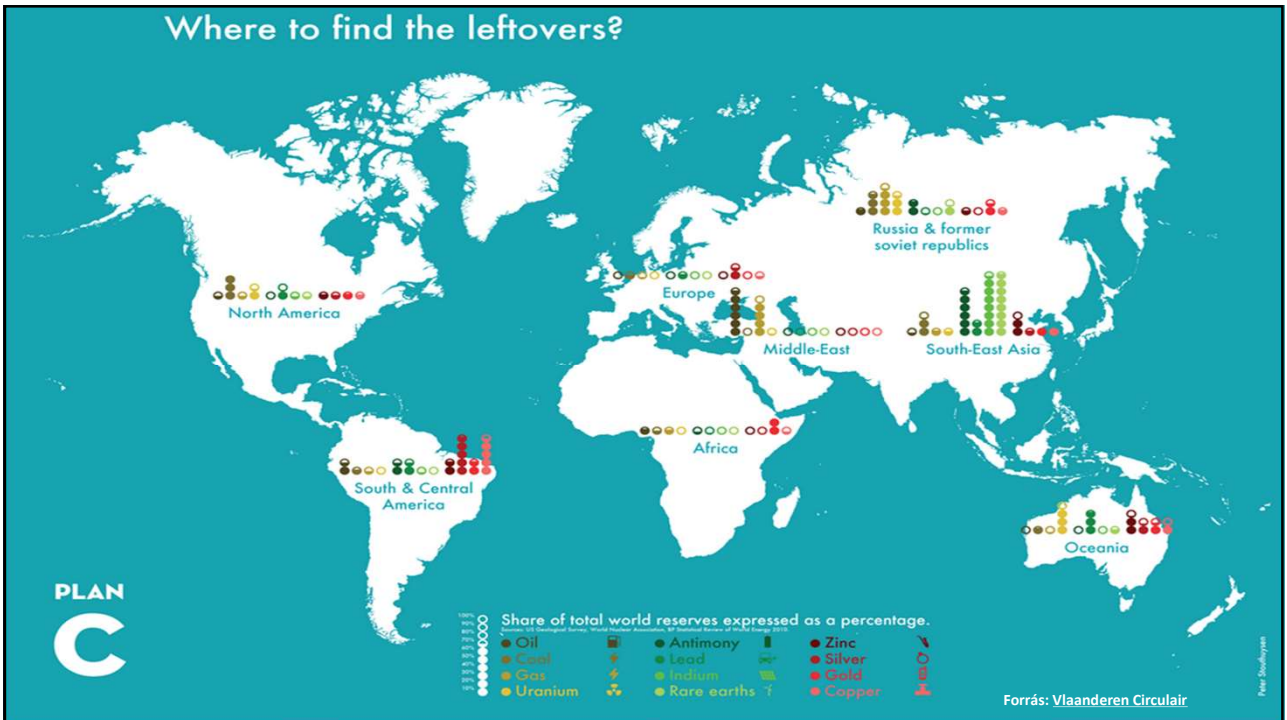
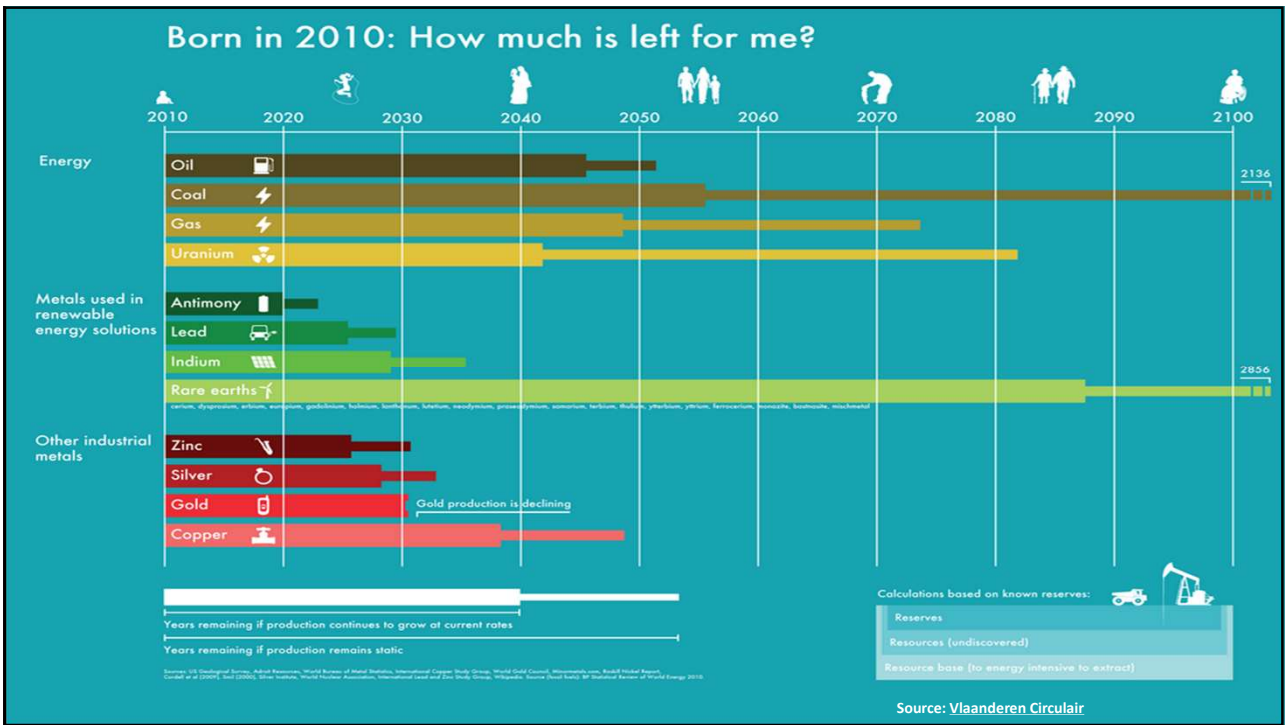

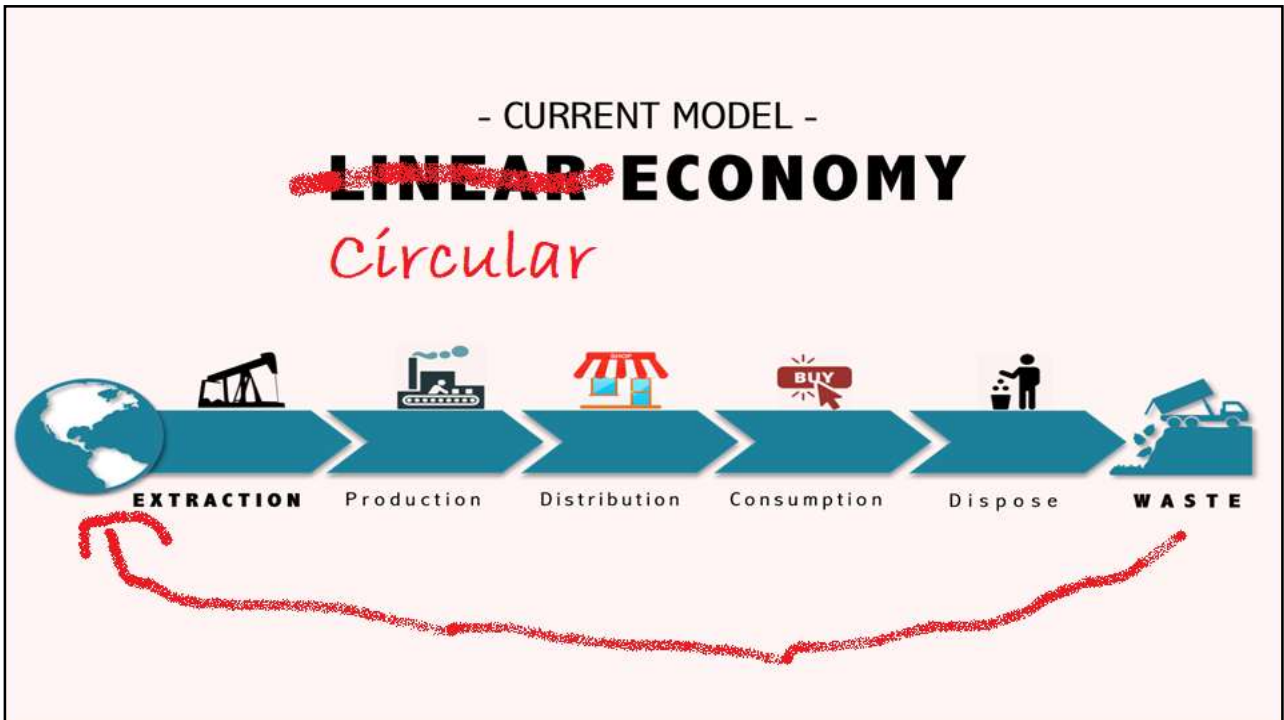
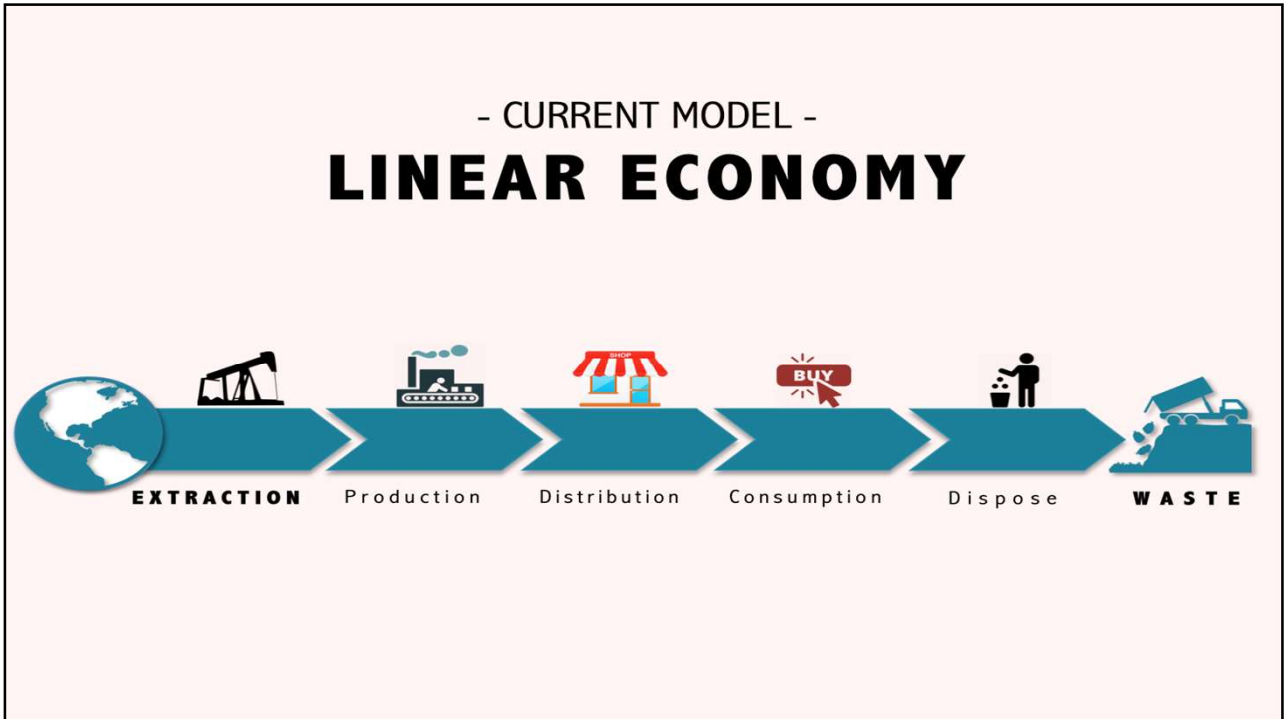

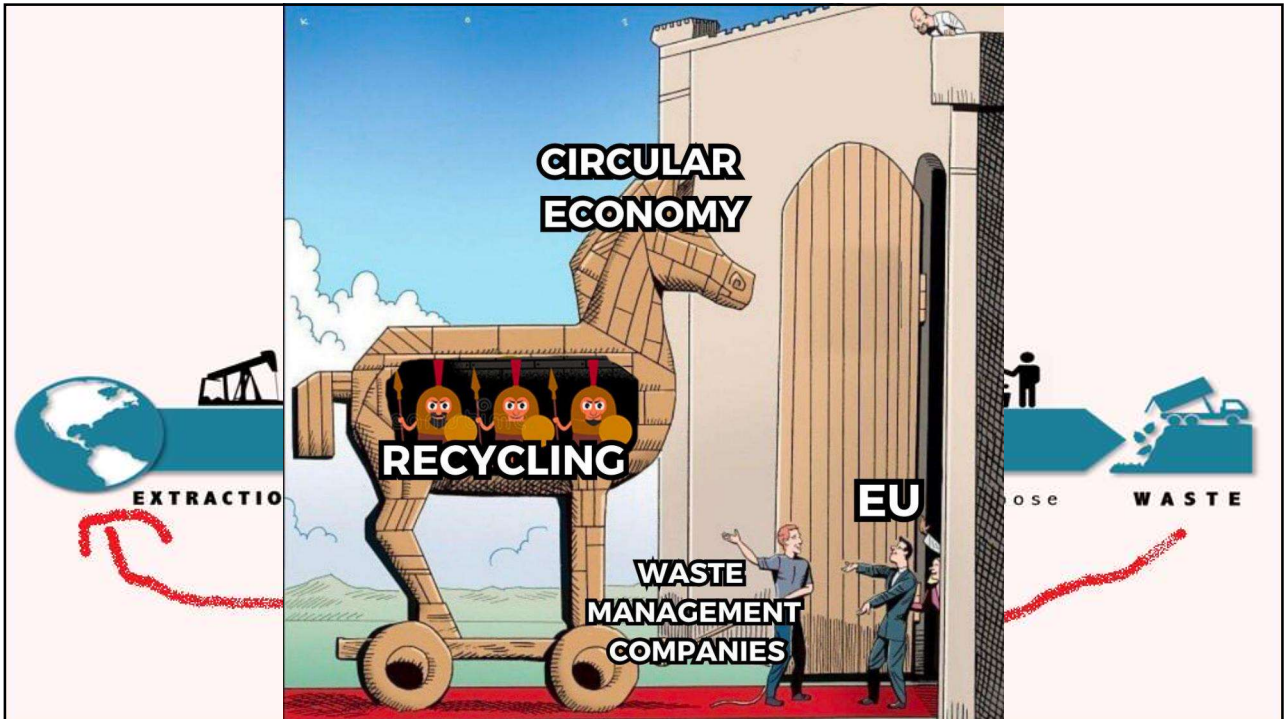

Join at [menti.com](https://menti.com) | use code 4884 2655 Mentimeter

## Instructions

Go to  
[www.menti.com](https://www.menti.com)

Enter the code  
**4884 2655**



Or use QR code

[f](#) [t](#) [h](#) [?](#) <#>

# Mentimeter



Do you think the circular economy has its own independent legitimacy in business, or should its development be supported and incentivized by the state?

How many levels are there in circularity?

# The Ladder of Circularity



## Levels of circularity: 10 R's

Order of priority

**High**



- Refuse:** prevent raw materials' use
- Reduce:** decrease raw materials' use per unit of product
- Redesign:** rethink product in view of circularity
- Reuse:** use product again (second hand)
- Repair:** maintain and repair product
- Refurbish:** revive product
- Remanufacture:** make new product from second hand
- Re-purpose:** re-use product but with other function
- Recycle:** salvage material streams with highest possible value
- Recover:** incinerate waste with energy recovery

**Low**



**Prof. dr. Jacqueline Cramer**  
 Utrecht University  
 Former Minister of Housing, Spatial Planning and the Environment

© J. Cramer

# The Ladder of Circularity



## Levels of circularity: 10 R's

Order of priority

High

- Refuse:** prevent raw materials' use
- Reduce:** decrease raw materials' use per unit of product
- Redesign:** rethink product in view of circularity
- Reuse:** use product again (second hand)
- Repair:** maintain and repair product
- Refurbish:** revive product
- Remanufacture:** make new product from second hand
- Re-purpose:** re-use product but with other function
- Recycle:** salvage material streams with highest possible value
- Recover:** incinerate waste with energy recovery

Low

© J. Cramer

# Service instead of product



## Service instead of product

**AGROLOOP**



<https://www.agroloop.eu/en/>



## The Ladder of Circularity

### Levels of circularity: 10 R's

Order of priority

**High**

- Refuse:** prevent raw materials' use
- Reduce:** decrease raw materials' use per unit of product
- Redesign:** rethink product in view of circularity
- Reuse:** use product again (second hand)
- Repair:** maintain and repair product
- Refurbish:** revive product
- Remanufacture:** make new product from second hand
- Re-purpose:** re-use product but with other function
- Recycle:** salvage material streams with highest possible value
- Recover:** incinerate waste with energy recovery

**Low**

© J. Cramer

# Cradle to Cradle (C2C)



Venlo City Hall



<https://www.ellenmacarthurfoundation.org/circular-examples/city-hall-from-cradle-to-cradle-venlo>

Kalundborg Symbiosis

<https://www.symbiosis.dk/en/>

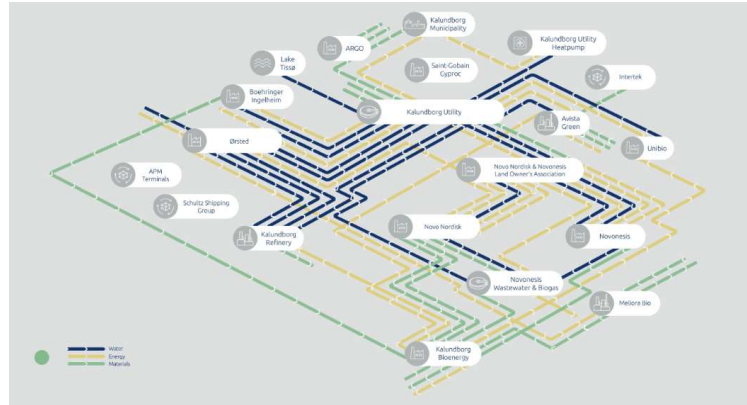

# Second Hand Product



Loop refillable packaging

<https://exploreloop.com/en/shop/>



Drunk as a pig?



# The Ladder of Circularity



## Levels of circularity: 10 R's

Order of priority

High

- Refuse:** prevent raw materials' use
- Reduce:** decrease raw materials' use per unit of product
- Redesign:** rethink product in view of circularity
- Reuse:** use product again (second hand)
- Repair:** maintain and repair product
- Refurbish:** revive product
- Remanufacture:** make new product from second hand
- Re-purpose:** re-use product but with other function
- Recycle:** salvage material streams with highest possible value
- Recover:** incinerate waste with energy recovery

Low

© J. Cramer

# Second Hand Product



Amsterdam Court House

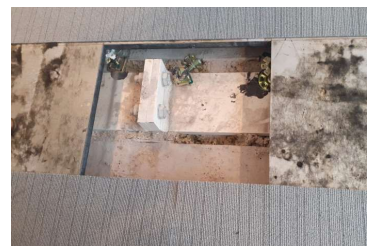

# The Ladder of Circularity

## Levels of circularity: 10 R's

Order of priority

**High**

- Refuse:** prevent raw materials' use
- Reduce:** decrease raw materials' use per unit of product
- Redesign:** rethink product in view of circularity
- Reuse:** use product again (second hand)
- Repair:** maintain and repair product
- Refurbish:** revive product
- Remanufacture:** make new product from second hand
- Re-purpose:** re-use product but with other function
- Recycle:** salvage material streams with highest possible value
- Recover:** incinerate waste with energy recovery

**Low**

© J. Cramer

# Modularity

FairPhone



Repair Café



# The Ladder of Circularity



## Levels of circularity: 10 R's

Order of priority

High

- Refuse:** prevent raw materials' use
- Reduce:** decrease raw materials' use per unit of product
- Redesign:** rethink product in view of circularity
- Reuse:** use product again (second hand)
- Repair:** maintain and repair product
- Refurbish:** revive product
- Remanufacture:** make new product from second hand
- Re-purpose:** re-use product but with other function
- Recycle:** salvage material streams with highest possible value
- Recover:** incinerate waste with energy recovery

Low

© J. Cramer

# Second Hand Material



"Circl" pavilion – ABN AMRO - Amsterdam

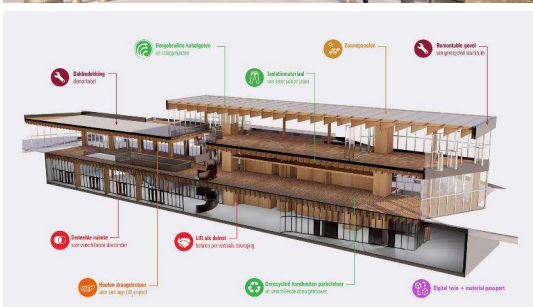

www.circl.nl

Styrofoam Green Program - Masterplast



<https://www.masterplast.hu/hungarocell-zold-program-oko-pontok/>

# The Ladder of Circularity



## Levels of circularity: 10 R's

Order of priority

High



- Refuse:** prevent raw materials' use
- Reduce:** decrease raw materials' use per unit of product
- Redesign:** rethink product in view of circularity
- Reuse:** use product again (second hand)
- Repair:** maintain and repair product
- Refurbish:** revive product
- Remanufacture:** make new product from second hand
- Re-purpose:** re-use product but with other function
- Recycle:** salvage material streams with highest possible value
- Recover:** incinerate waste with energy recovery

Low

© J. Cramer

# Made of...



Isolation made of denim



<https://www.denimtex.nl/>

Lamps made of PET bottles and water



# The Ladder of Circularity



## Levels of circularity: 10 R's

Order of priority

**High**

- Refuse:** prevent raw materials' use
- Reduce:** decrease raw materials' use per unit of product
- Redesign:** rethink product in view of circularity
- Reuse:** use product again (second hand)
- Repair:** maintain and repair product
- Refurbish:** revive product
- Remanufacture:** make new product from second hand
- Re-purpose:** re-use product but with other function

**Low**

- Recycle:** salvage material streams with highest possible value
- Recover:** incinerate waste with energy recovery

© J. Cramer

# Salvage Material



Smartcrusher – Circular Beton Production

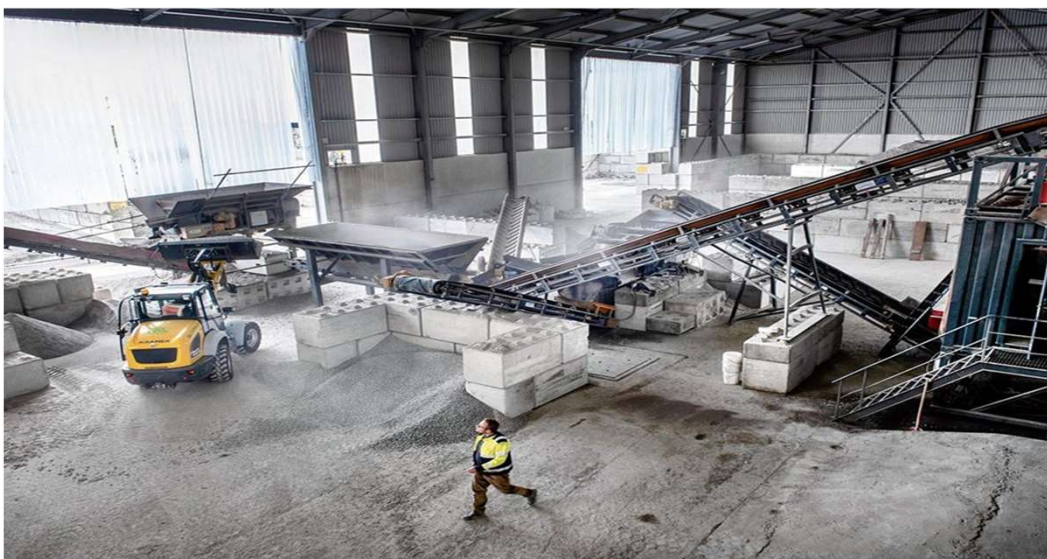

<https://www.slimbreker.nl/smartcrusher.html>



Thank you!





**MISKOLCI**  
EGYETEM  
UNIVERSITY OF MISKOLC



EnergyWaterFoodClimate  
**NEXUS**  
INTERNATIONAL SUMMIT  
AUGUST 26-28, 2025  
EUROPE  
MISKOLC, HUNGARY

## Personal issues about circularity: approach to energy saving

**László Berényi, PhD**  
Institute of Management Science

*27 August 2025*



### Accelerated world

- Shortening product lead times
  - Business pressure
  - Failures and quality issues
  - Shorter time to generate revenues and return
- Changing customer needs
  - Partially forced changes
  - Marketing actions
  - Technology acceptance and preparedness
- IT in focus
  - Big data
  - Virtualization
  - Artificial intelligence



- Shorter product life cycles
- Pressure on quick decisions
- Unreliable quality
- Greenwashing
- Increased overuse of resources and energy



Towards or against sustainability?

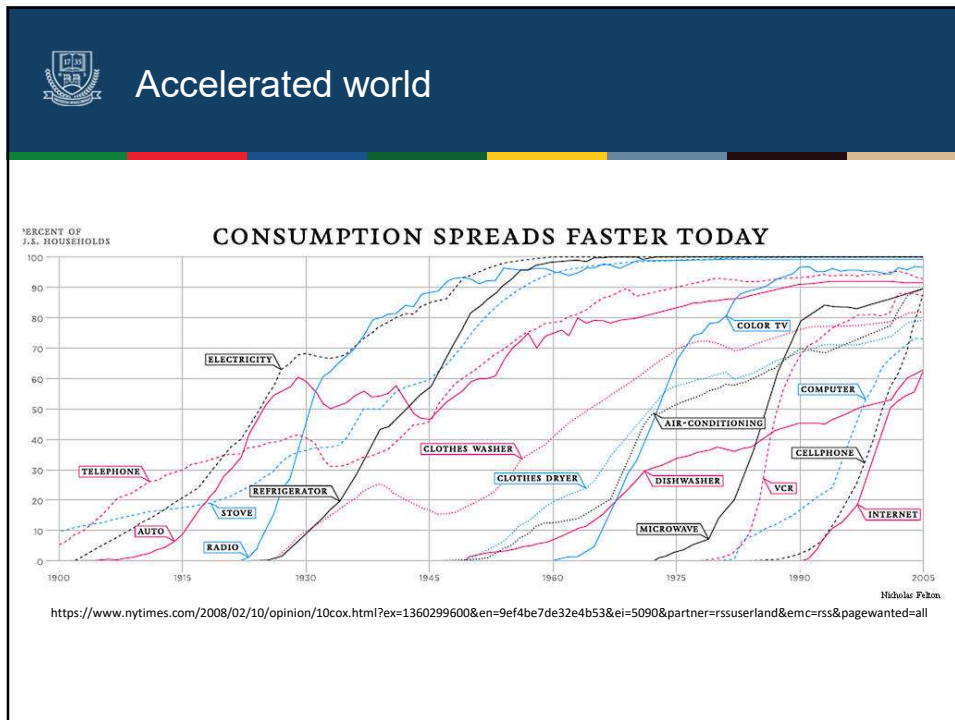



## Energy: key issue

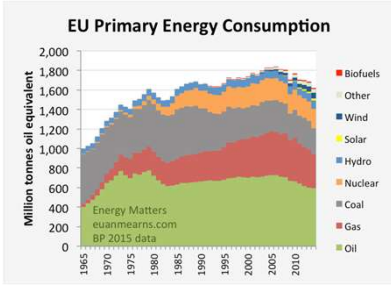

Energy Matters  
euanmearns.com  
BP 2015 data

<https://euanmearns.com/eu-2020-renewable-energy-targets-part-i>



**System level response:**  
**Energy transition**



**Individual-level response:**  
**Energy saving**

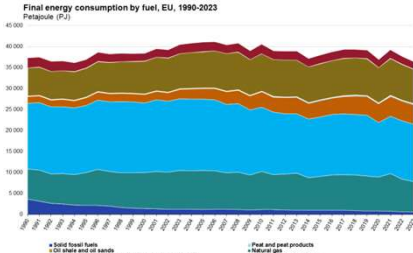

Source: Eurostat (online data code: neq\_baf\_13)

[https://ec.europa.eu/eurostat/statistics-explained/index.php?title=Energy\\_statistics\\_-\\_an\\_overview](https://ec.europa.eu/eurostat/statistics-explained/index.php?title=Energy_statistics_-_an_overview)



## An empirical study

- Topic
  - Use of energy-saving functions of household appliances
  
- Contribution to circular economy
  - Increased efficiency leads to lower resource use
  - Waste reduction and lower carbon footprint
  - **Raising consumer awareness**
  
- Method
  - Survey for checking opinion patterns
  - Model building using Technology Acceptance Model
  
- Sample
  - Pilot study among higher education students
  - 198 responses collected in 2025

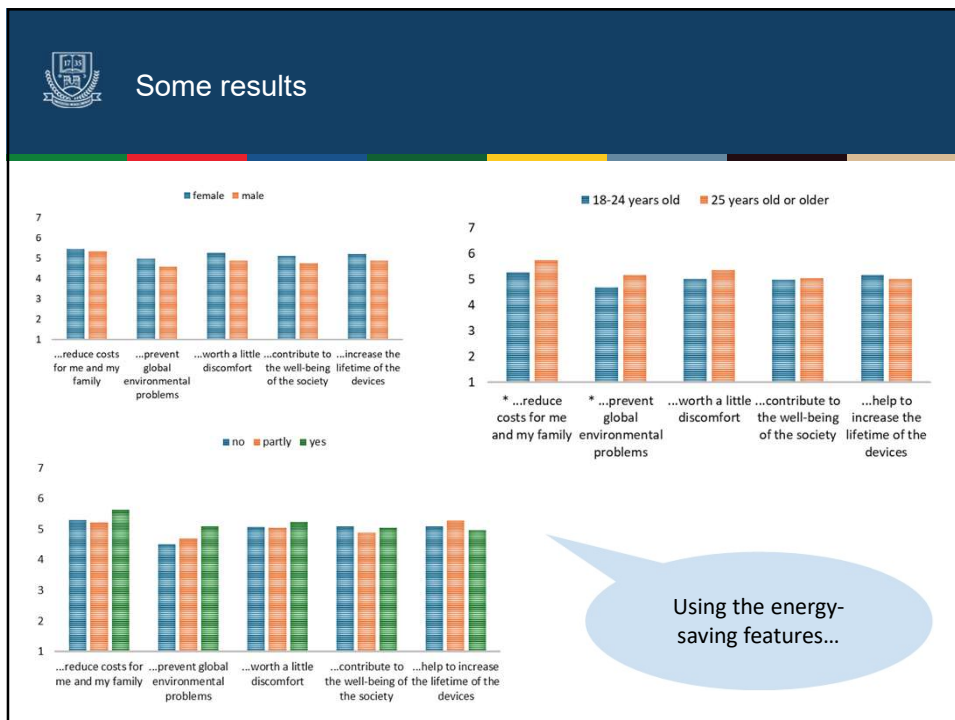
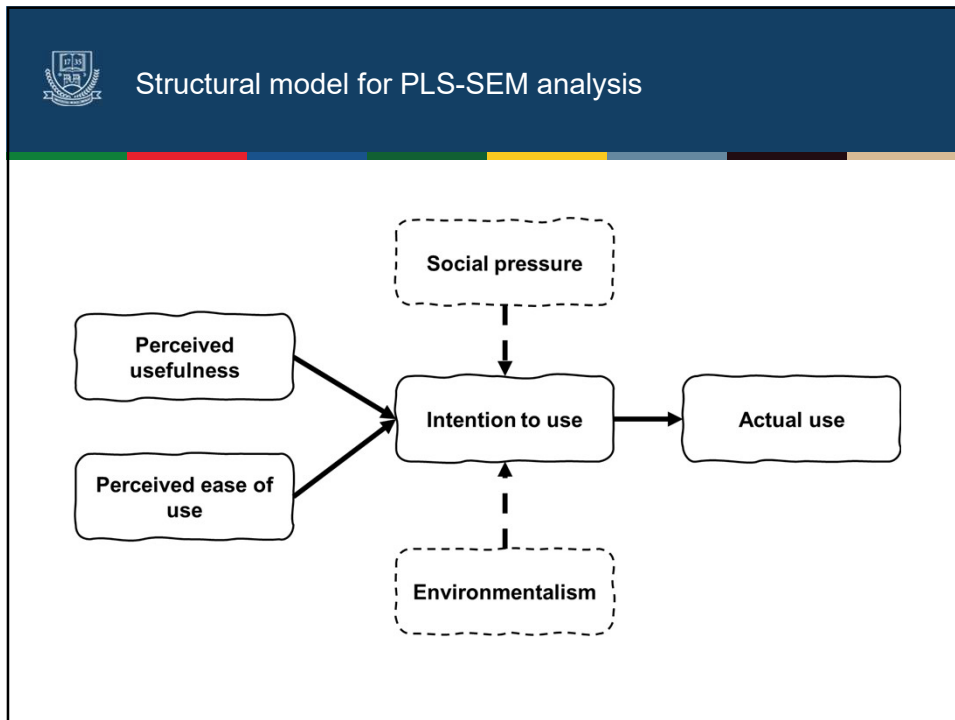

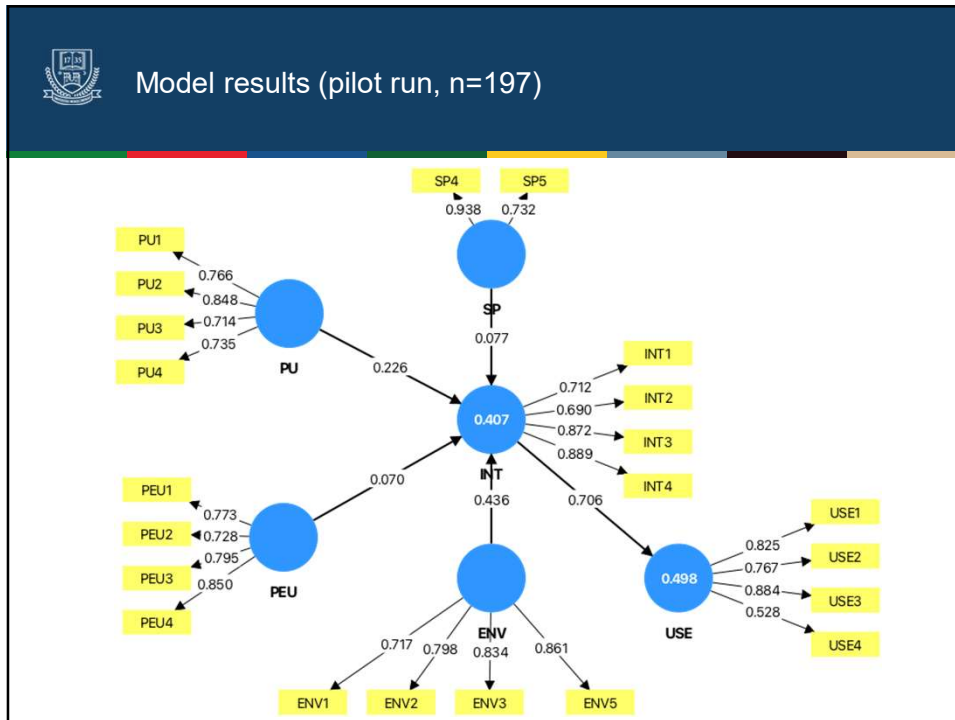

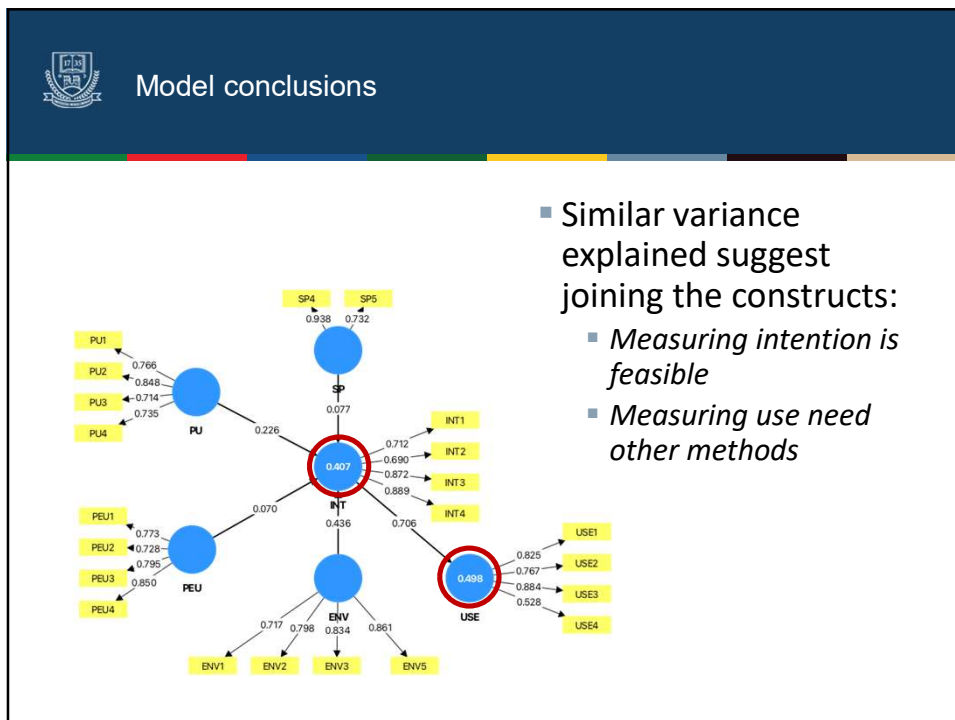
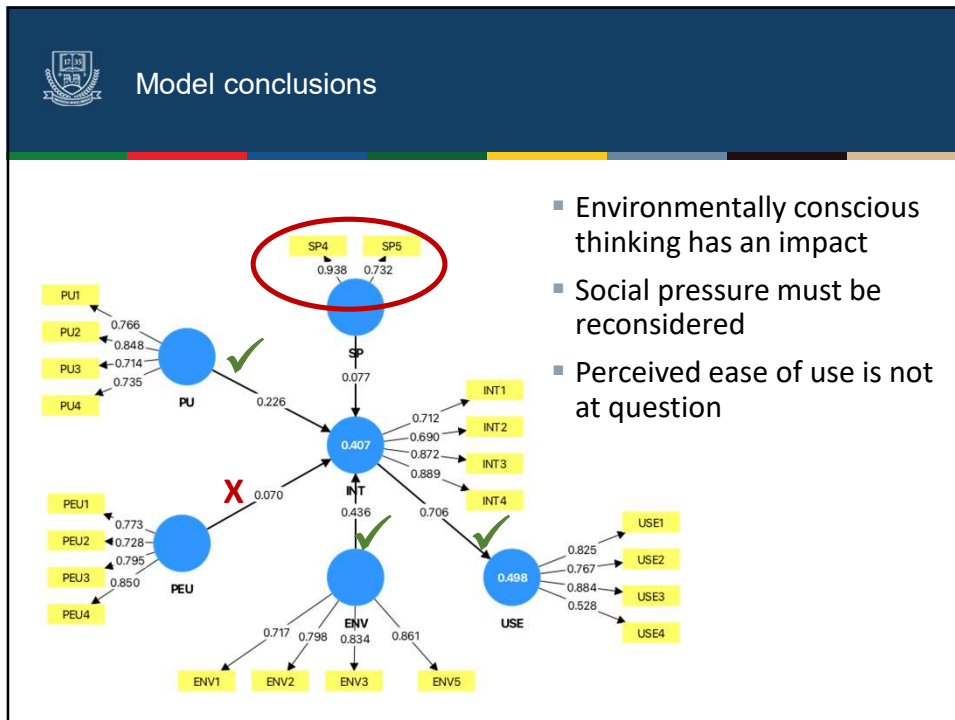



## Conclusions

- Circular economy is an umbrella construct that enables sustainable strategies and actions
  - Diverse topics
  - No ultimate responses
- Understanding the acceptance of technologies has a crucial role
  - Modelling by TAM model is purposeful
  - Lessons learned from opinion patterns
  - Building a knowledge base to support effective strategies and collaboration
- Investigating the use of energy-saving features is just a case study in the field



**MISKOLCI**  
EGYETEM  
UNIVERSITY OF MISKOLC

László Berényi, PhD



[laszlo.berenyi@uni-miskolc.hu](mailto:laszlo.berenyi@uni-miskolc.hu)

Personal issues about circularity:  
approach to energy saving



The image features the MUT logo on the left, which consists of a stylized graphic of a curved line and several colored diamonds (blue, yellow, red) above the text 'MUT MANGOSUTHU UNIVERSITY OF TECHNOLOGY'. To the right of the logo is a decorative graphic of several overlapping geometric shapes in shades of red, blue, and yellow. The main text is centered and reads: 

**The Role of Entrepreneurship in the Development of the Circular Economy in KwaZulu-Natal, South Africa**

**Energy-Water-Food-Climate Nexus International Summit**

**Dr Xolile Ngubane**  
[xolilengubane@mut.ac.za](mailto:xolilengubane@mut.ac.za)  
**27 August 2025**

## INTRODUCTION

The circular economy envisions a world without waste, where resources circulate indefinitely, maximising resource efficiency and minimising environmental impact by promoting the continuous use, reuse, and recycling of materials and products

The concept of the circular economy is not new to South Africa, given the country's challenge with adequate resources of water and energy.

- ✦ Recycling of grey water supplements available water by up to up 13% and renewable energy contribution rising to 11% of South Africa's energy supply (Godfrey, *et al.* 2021)



## Entrepreneurship – Circular Economy

- ✦ Entrepreneurship is crucial to the circular economy, **driving innovation and job creation** by transforming waste into valuable resources and developing new business models. It enables industries with significant environmental impacts to adopt circular economy strategies.
- ✦ Entrepreneurs tackle waste management by developing innovative solutions for waste collection, recycling, and composting, turning waste into valuable resources.
- ✦ The circular economy encourages businesses to focus on waste minimisation, product development, repair services, and remanufacturing.
- ✦ **Technology-driven small businesses** play a key role by promoting sustainable solutions through digital platforms and collaboration, supporting the transition to a more sustainable economy



## Evidence of Employment Creation - Circular Economy in KZN

The **National Cleaner Production Centre South Africa (NCP-C-SA)** led the **KZN Industrial Symbiosis Programme (KISP)**, launched in 2014.

- ✦ Companies to **trade waste and surplus resources**, such as sawdust, organic waste, energy, water, and logistics, with other businesses that can repurpose them.
- ✦ **Cost savings**,
- ✦ Diverting waste from landfills - 518 tonnes of waste away from the already strained landfills, within a period of seven years (2015 to 2022).
- ✦ Reduction in greenhouse gas emissions, and fosters



## Evidence of Employment Creation - Circular Economy in KZN

- ✦ **New business opportunities for small and micro enterprises (SMMEs)**- creates SMME opportunities.
- ✦ Supports communities of individuals who scavenge waste for a living and are liberally referred to as 'waste entrepreneurs',
- ✦ Encourages the community to reconsider their attitude towards waste



## Evidence of Employment Creation - Circular Economy in KZN

### Buffelsdraai Landfill Site Community Reforestation Project

- ✦ The **Buffelsdraai Landfill Site Community Reforestation Project** –grassroots entrepreneurship within a circular economy framework.
- ✦ encourage individuals who have keen interest in reforestation, and are described as **Treepreneurs"**
- ✦ Grow indigenous trees in their homes in exchange for essentials
- ✦ Means of survival.
- ✦ It addresses the two challenges of ecological restoration and unemployment
- ✦ It exemplifies how circularity—through ecosystem restoration—can function as employment generation and poverty alleviation.

Challenge – Fairness



## Evidence of Employment Creation - Circular Economy in KZN

### KZN Department of Economic Development, Tourism and Environmental Affairs (EDTEA)

The **KZN-EDTEA** hosts various initiatives that indirectly bolster circular entrepreneurship:

- Activities like **waste pickers' capacity-building workshops**, **entrepreneurship development workshops**, and **career & entrepreneurship expos** were actively promoted in late 2023 ([kznedtea.gov.za](http://kznedtea.gov.za)).
- These platforms foster awareness, skills development, and often serve as entry points for circular-business ideas.

EDTEA workshops and forums create awareness and conducive conditions for circular entrepreneurship. Furthermore, the broader **Economic Development Council** dialogues emphasise **inclusive, sustainable growth**, which provides favourable policy settings and strategic direction that can support circular start-ups.



## Mangosuthu University of Technology

- ✦ The SA Government emphasises SMME development as an essential policy urgency to encourage the founding of feasible enterprises and new businesses, enabling job creation and lessening unemployment and poverty (Technology Innovation Agency, 2020).
- ✦ The depressed economic climate is among the biggest challenges facing SMME development in SA and is among the critical concerns for the small business department (The Department of Small Business Development, 2020). This is especially the case since SMMEs rely heavily on government grants.
- ✦ Entrepreneurship and SMME policies are regarded as integral components of the complex regional ecosystem, alongside other stakeholders, including institutions, entrepreneurs, and small business owners (Dvouletý, Srhoj & Pantea, 2021).



## Circular Economy- Technology and Innovation Intersections

- ✦ Innovation is key to the survival and sustainability of the circular economy.
- ✦ The circular model creates value by simultaneously enabling economic growth and positive ecological impacts.
- ✦ Ultimately, the circular economy is a transformative process that reimagines and redesigns social and business interactions.
- ✦ Identification of Circular economy opportunities is essential in resource-intensive sectors such as manufacturing, agriculture, human settlements and transport.
- ✦ Devise strategies to address 'early-stage' product design and resource demand.



## Technology Stations Programme

### Entrepreneurship Development & Support

Identification of low-entry barrier sectors to promote entrepreneurship:

Downstream Chemicals manufacturing-

- ✚ Limited skills and technical know-how
- ✚ Employment opportunities
- ✚ Local market
- ✚ Relatively safe

Chemical formulations: Water-based – high levels of water consumption (76% to 85%)

Durban's Tiered Pricing Strategy

Up to 6 kl: R37.70 per kl (3.77 cents per litre)

Usage above 45 kl: R100.70 per kl (10.07 cents per litre) (eThekwinini Municipality)

Common Detergents - SMMEs

1000 L	Water	Cost/L	Cost of water	R/L Lower T	Cost of water	R/L higher T
D/W	760	4.47	28.652	0.028652	76.532	0.076532
HSC	780	2.94	29.406	0.029406	78.546	0.078546
P/G	800	9.2	30.16	0.03016	80.56	0.08056
TB	600	3.07	22.62	0.02262	60.42	0.06042

Pure water – preferable ( vs hard water) – no pre-treatment

Hard water in rural areas that rely on groundwater, and in some cities, Durban

R0.30 to R2.85 per litre to treat hardness

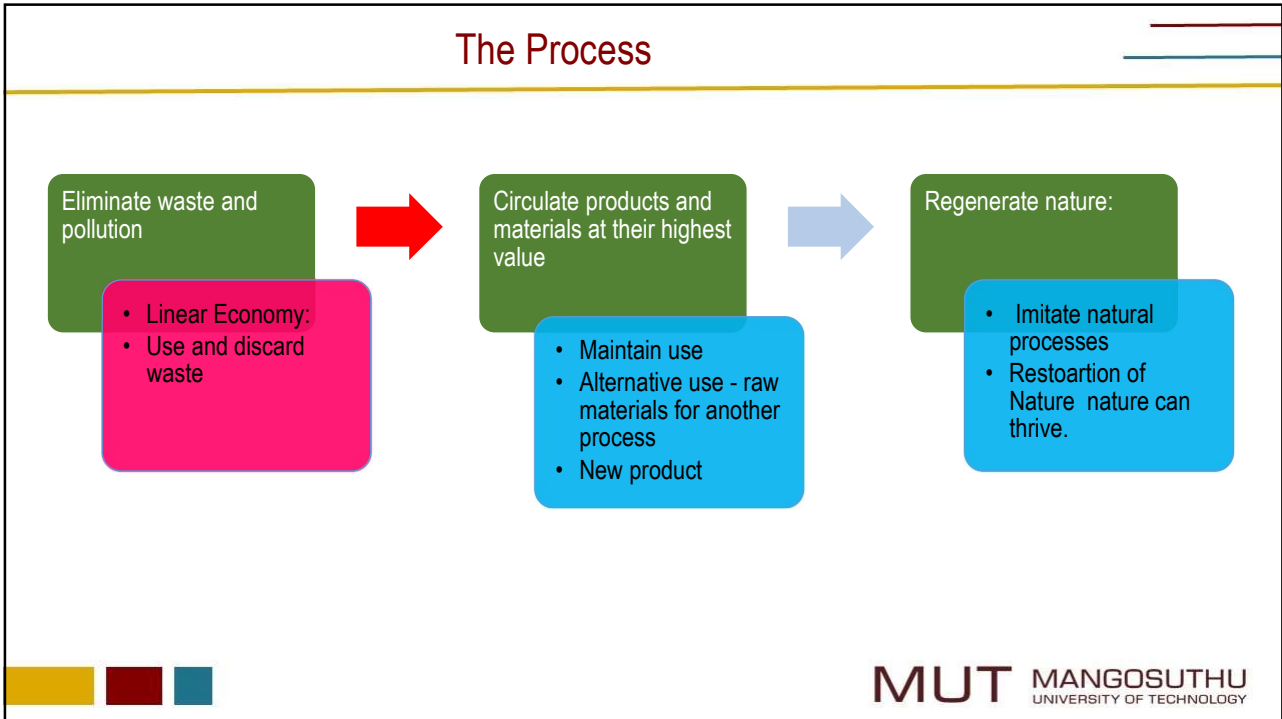

Manufacturing Strategy	Implementations	Practical action points for Chemical Manufacturing SMMEs (MUT-TSC)
Resource efficiency	<ul style="list-style-type: none"> <li>• Minimising resource use</li> <li>• Reduce the use of virgin material at the source through</li> <li>• Improvements in process efficiencies (innovations on product design and processes,</li> <li>• Reuse and recycling.</li> <li>• Improved value proposition ( how value is created, delivered, captured and presented to the market</li> </ul>	<ul style="list-style-type: none"> <li>• Reformulation of products</li> <li>• Reduce water in the formulation</li> <li>• Workflow design to reduce water used in washing/cleaning and rinsing.</li> <li>• Improve storage to align with raw materials properties that improve shelf life</li> <li>• Packaging that uses minimal material or can be reused</li> <li>• Price reduction for reuse of packaging</li> </ul>

**MUT MANGOSUTHU**  
UNIVERSITY OF TECHNOLOGY

Manufacturing Strategy	Implementations	Practical action points for Chemical Manufacturing SMMEs (MUT-TSC)
Resource sharing	Resource sharing is about collaborative consumption models that enable multiple users to use the same resource over time, such as sharing services, renting, or leasing of products.	<ul style="list-style-type: none"> <li>• Utilisation of shared facilities (Incubators/TBIs/Shared Manufacturing Facilities)</li> <li>• Shared Office Spaces</li> <li>• Outsourcing testing and analysis</li> </ul>



Manufacturing Strategy	Implementations	Practical action points for Chemical Manufacturing SMMEs (MUT-TSC)
Reuse Products	This will include products recovered from returns, take-back programmes or leases, parts and/or components that are refurbished, repaired, remanufactured, or treated to be “as good as new” or “like-new”, minimising waste, conserving resources and keeping products in use for longer.	<ul style="list-style-type: none"> <li>• Grey water usage</li> <li>• Packaging/Manufacturing – systematic handling of large vs smaller orders. ( Tanks vs Drums)</li> <li>• Reworking products that are below specifications</li> </ul>



Manufacturing Strategy	Implementations	Practical action points for Chemical Manufacturing SMMEs (MUT-TSC)
Systemic change	<p>A systemic change includes both structural and behavioural transformations for shifting from a linear to a circular business model.</p> <p>It involves enforcing collaborations among businesses, governments, consumers, and other stakeholders to reshape production, consumption, and waste management practices.</p>	<ul style="list-style-type: none"> <li>• Implementation of Quality Management Systems</li> <li>• Customer care/consumer forum</li> <li>• Industry/stakeholder memberships</li> <li>• Lobby government for workable waste management policies and practices.</li> <li>• Functional and vibrant Regional ecosystem</li> </ul>



**Necessity-driven entrepreneurship**

- ✦ As a country facing high levels of unemployment, poverty and inequality, end-of-life products are often repaired and reused, driven largely by an active informal sector (Godfrey *et al.* 2021).
- ✦ In addressing these long-standing challenges, the NDP 2030 emphasises that the first step to eradicating poverty in South Africa is to boost employment, and this is a task which can only be achieved if the economy proliferates, and by intentionally involving those who have been historically disadvantaged (SA Government, 2012).
- ✦ The successful establishment and prosperity of SMMEs can generate a viable strategy by which the incomes at the lower end of salaries and wages can be augmented, thereby reducing the high levels of inequality (Bhorat *et al.*, 2018).



The 2019 White Paper on Science, Technology and Innovation also supports strong collaboration amongst relevant government departments in providing technological and innovation support to SMEs that will ensure the realisation of new markets (Department of Science and Technology, 2019b). The 2020/21 Revised Annual Performance Plan of the DSBD regards the preparedness across all sectors, including Government and the private sector, towards operative leadership and management regarding SMME support as a valuable opportunity deserving further exploration (The Department of Small Business Development, 2020), as it seeks to solidify the government mandate towards this sector.



## Way forward

- ✦ Climate-conscious entrepreneurs are necessary agents of change in society and the economy, as they endeavour to create innovative and sustainable solutions to the challenges of climate change.
- ✦ New products, services, business models and entire ecosystems are introduced to the market-combat climate change.
- ✦ Attract and bring together different people and communities to cooperate, and by combining their resources,
- ✦ It is possible to produce solutions that combat climate change.

“What we want is possible”



## Risk- Management:

- ✚ Requires a supportive entrepreneurship and innovation ecosystem
- ✚ Technology business incubation – enhanced role
  - Technology/Innovation partnerships
  - Cost savings
  - Expertise



## Acknowledgements

- 
- ✚ Vice-Chancellor & Principal - Vision
- ✚ DVC – Research, Innovation & Engagements – Funding
- ✚ Marcomms - Carrying the vision and managing logistical arrangements

Type the label of the photo here



THANK YOU

• SIYABONGA

• ENKOSI

• KÖSZÖNÖM

Type the label of the photo here

MUT MANGOSUTHU  
UNIVERSITY OF TECHNOLOGY



**Synthesis & Screening Sodium Mordenite and Potassium Merlinoite Deposited Carbon [Na-MOR/C & K-MER/C] as Hydrogen Physisorbent**

**Ariyo Hidayanto**

*Institute of Energy, Ceramic, and Polymer Technology, University of Miskolc, 3515*

Energy Water Food Climate Nexus  
International Summit Scientific Program  
August 27, 2025



## **INTRODUCTION**

- Carbon deposition will increase zeolite's surface area to form mesoporous framework
- Sodium Mordenite [Na-MOR] zeolite advantages can incorporate gas storage
- Potassium Merlinoite [K-MER] is a relatively novel synthetic zeolite with good adsorption ability





*Ariyo Hidayanto*  
*Synthesis & Screening Sodium Mordenite and Potassium Merlinoite Deposited Carbon [Na-MOR/C & K-MER/C] as Hydrogen Physisorbent*

**2**

## Na-Mordenite

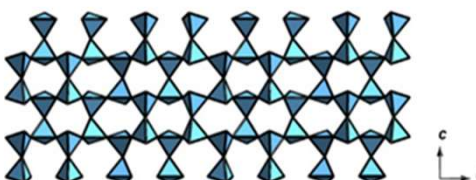
- Material type :  
 $[(\text{Na}_2, \text{K}_2, \text{Ca})_4(\text{H}_2\text{O})_{28}]$   
 $[\text{Al}_8\text{Si}_{40}\text{O}_{96}]$
- Consist of 8mRs and 12mRs of 2D channels
- Versatility for many purposes
- Good thermal stability







*Ariyo Hidayanto*  
 Synthesis & Screening Sodium Mordenite and Potassium Merlinoite Deposited Carbon [Na-MOR/C & K-MER/C] as Hydrogen Physisorbent

**3**

## K-Merlinoite

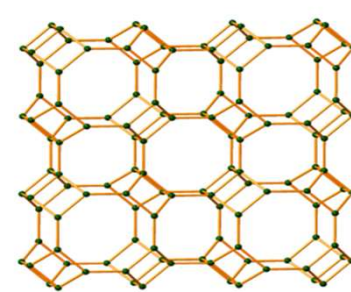
- Material type :  
 $[\text{K}_{11}\text{Al}_{11}\text{Si}_{21}\text{O}_{64}(\text{H}_2\text{O})_{20}]$
- Consists of 3D interconnected of 8mRs
- It has a remarkable adsorption capacity





*Ariyo Hidayanto*  
 Synthesis & Screening Sodium Mordenite and Potassium Merlinoite Deposited Carbon [Na-MOR/C & K-MER/C] as Hydrogen Physisorbent

**4**

## Zeolite – Carbon Incorporation

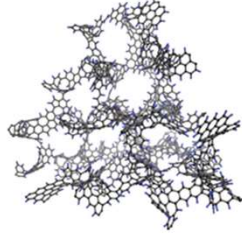

- Invented in 1980
- Carbonizing the mixture of silica gels and phenol at 1000 °C
- Potential in reaching surface area until  $\pm 4000 \text{ m}^2/\text{g}$



Ariyo Hidayanto  
 Synthesis & Screening Sodium Mordenite and Potassium Merlinoite Deposited Carbon [Na-MOR/C & K-MER/C] as Hydrogen Physisorbent

5

## Research Flow Chart

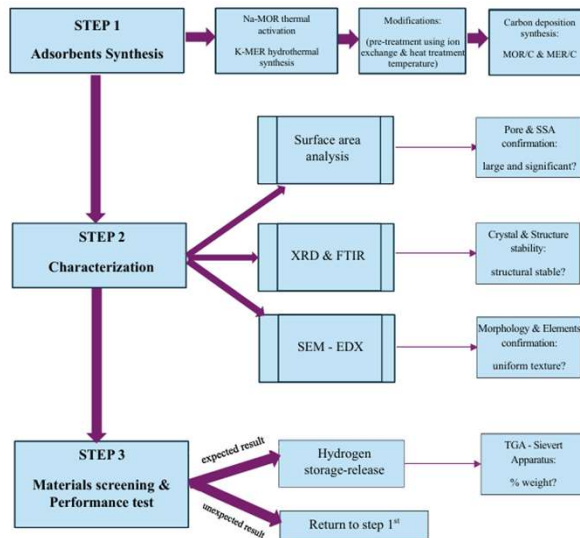

Ariyo Hidayanto  
 Synthesis & Screening Sodium Mordenite and Potassium Merlinoite Deposited Carbon [Na-MOR/C & K-MER/C] as Hydrogen Physisorbent

6

## H<sub>2</sub> Adsorbent



Samples

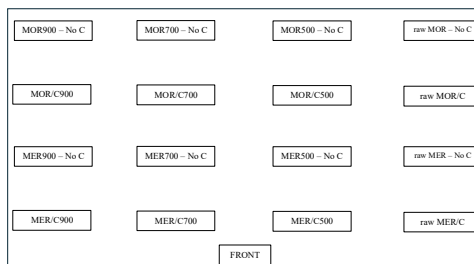

Cross-sectional position



Ariyo Hidayanto

Synthesis & Screening Sodium Mordenite and Potassium Merlinoite Deposited Carbon [Na-MOR/C & K-MER/C] as Hydrogen Physisorbent

7

## Unit Operation System



C-deposition reactor



Materials screening test



Ariyo Hidayanto

Synthesis & Screening Sodium Mordenite and Potassium Merlinoite Deposited Carbon [Na-MOR/C & K-MER/C] as Hydrogen Physisorbent

8

## Structure Identification

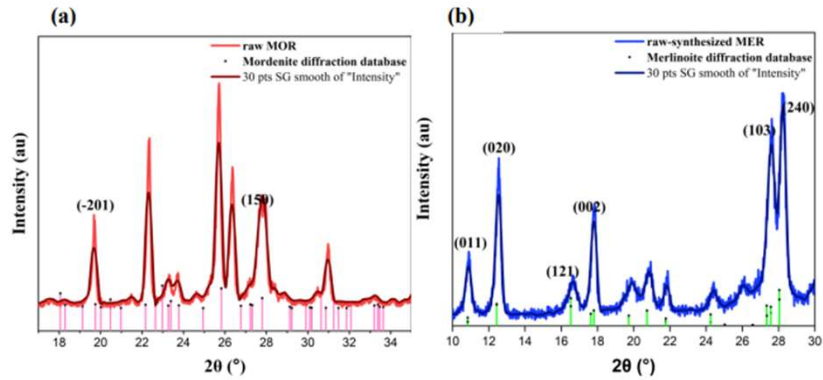

XRD patterns of the raw MOR (a) and raw MER (b) before heat treatment



Ariyo Hidayanto  
 Synthesis & Screening Sodium Mordenite and Potassium Merlinoite Deposited Carbon [Na-MOR/C & K-MER/C] as Hydrogen Physisorbent

## Na-Mordenite/C Morphology

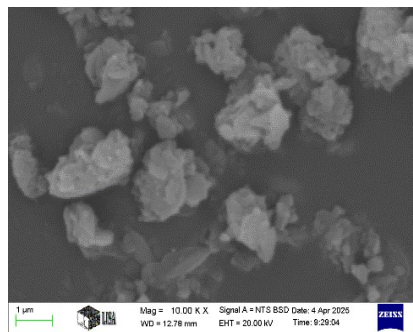

raw MOR

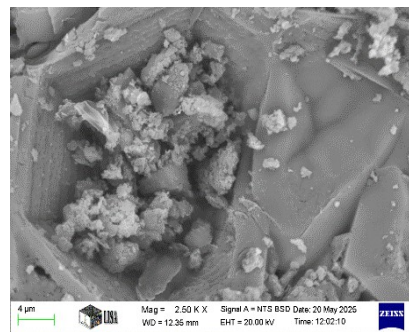

raw MOR + C deposition (raw MOR/C)



Ariyo Hidayanto  
 Synthesis & Screening Sodium Mordenite and Potassium Merlinoite Deposited Carbon [Na-MOR/C & K-MER/C] as Hydrogen Physisorbent

## Na-Mordenite/C Morphology

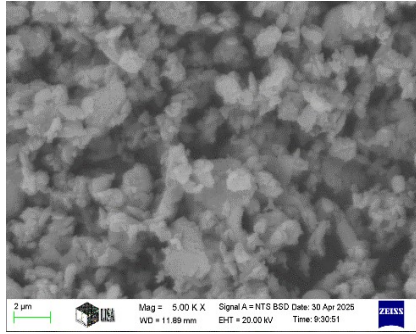

raw MOR + heat treatment 700 °C  
(MOR700)

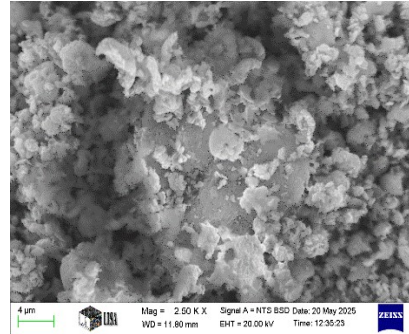

raw MOR + heat treatment 700 °C + C  
deposition (MOR/C700)



Ariyo Hidayanto  
Synthesis & Screening Sodium Mordenite and Potassium Merlinoite Deposited Carbon [Na-MOR/C & K-MER/C] as Hydrogen Physisorbent

11

## Na-Mordenite/C Morphology

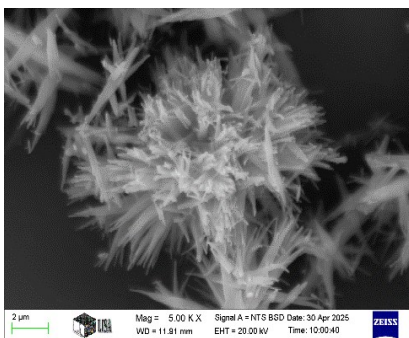

raw MOR + heat treatment 900 °C  
(MOR900)

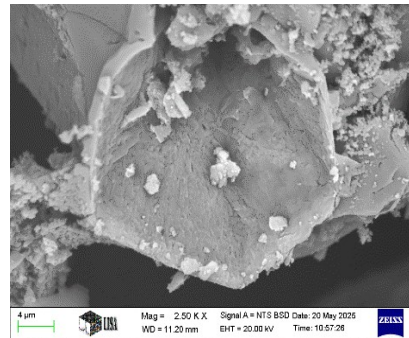

raw MOR + heat treatment 900 °C + C  
deposition (MOR/C900)



Ariyo Hidayanto  
Synthesis & Screening Sodium Mordenite and Potassium Merlinoite Deposited Carbon [Na-MOR/C & K-MER/C] as Hydrogen Physisorbent

12

## Surface Area Data

Samples	Single Point Surface Area	BET Surface Area	Langmuir Surface Area
	m <sup>2</sup> /g		
raw MOR	14.8801	15.0820	20.5736
raw MOR + heat treatment 700 °C	115.8103	113.4950	150.3979
raw MOR + heat treatment 900 °C	9.7016	10.0896	14.0041
raw MER	7.1813	7.4664	10.3826
raw MER + heat treatment 700 °C	6.8604	7.1282	9.9140
raw MER + heat treatment 900 °C	5.7979	6.0306	8.3980



Ariyo Hidayanto

Synthesis & Screening Sodium Mordenite and Potassium Merlinoite Deposited Carbon [Na-MOR/C & K-MER/C] as Hydrogen Physisorbent

13

## Adsorbent Screening result

P<sub>operation</sub>: 6 bar

T<sub>operation</sub>: 25 °C

t<sub>operation</sub>: 30 minutes

Samples	Hydrogen storage capacity (% weight of H <sub>2</sub> adsorbed on the adsorbent surface)
raw MOR/C	0.85
MOR/C700	0.65
MOR700	0.58
MOR500	0.57
raw MOR	0.53
MOR/C500	0.27
MOR900	0.18
MOR/C900	0.16



Ariyo Hidayanto

Synthesis & Screening Sodium Mordenite and Potassium Merlinoite Deposited Carbon [Na-MOR/C & K-MER/C] as Hydrogen Physisorbent

14

## H<sub>2</sub> Storage Materials Database

Material	Hydrogen storage capacity (wt %)	Pressure (bar)	Temperature (°C)
NaBH <sub>4</sub> (metal hydride based)	10.8	3	450 - 500
Mg + FeV + activated carbon (carbon based)	6.685	6 - 13	250
TiZrNbTa (high-entropy alloys based)	1.67	2	20
MgH <sub>2</sub> + 10 mol % TiH <sub>2</sub> (Mg-alloys based)	1.2	100	40
MgZrTiFe <sub>0.5</sub> Co <sub>0.5</sub> Ni <sub>0.5</sub> (high-entropy alloys based)	1.2	25	500
Nano LaNi <sub>5</sub> + carbon (carbon based)	1.1	10	26
<b>raw MOR/C – recent study</b>	<b>0.85</b>	<b>6</b>	<b>25</b>
g-C <sub>3</sub> N <sub>4</sub> (graphitic carbon based)	0.78	37	26
CuNi@UIO-66 (inorganic-organic based)	0.74	60	25
Activated carbon	0.67	100	30

Reference: [1] [4] [9]



15

## Future Perspective

1. Materials screening ; characterization → structure, elements, morphology, and surface area for all samples
2. Real-time experiment of hydrogen adsorption-desorption with various P, T, and time reaction using Sievert equipment
3. Development of Langmuir and Freundlich adsorption model and Pseudo 1<sup>st</sup> order kinetic equation
4. Hydrogen storage experiment from different materials: zeolite imidazole framework (ZIF)



Ariyo Hidayanto  
Synthesis & Screening Sodium Mordenite and Potassium Merlinoite Deposited Carbon [Na-MOR/C & K-MER/C] as Hydrogen Physisorbent

16

## REFERENCES

1. A. I. Osman et al., "Innovations in hydrogen storage materials: Synthesis, applications, and prospects," *J Energy Storage*, vol. 95, p. 112376, Aug. 2024, doi: 10.1016/J.EST.2024.112376
2. B. Erdoğan Alver and M. Sakızci, "Hydrogen (H<sub>2</sub>) adsorption on natural and cation-exchanged clinoptilolite, mordenite and chabazite," *Int J Hydrogen Energy*, vol. 44, no. 13, pp. 6748–6755, Mar. 2019, doi: 10.1016/J.IJHYDENE.2019.01.203.
3. G. D. Gatta and P. Lotti, "Systematics, crystal structures, and occurrences of zeolites," in *Environmental and Pharmaceutical Applications Micro and Nano Technologies*, Elsevier, 2019, pp. 1–25. doi: 10.1016/B978-0-12-814617-0.00001-3.
4. H. Hong, H. Guo, Z. Cui, A. Ball, and B. Nie, "Structure modification of magnesium hydride for solid hydrogen storage," *Int J Hydrogen Energy*, vol. 78, pp. 793–804, Aug. 2024, doi: 10.1016/J.IJHYDENE.2024.06.327.
5. H. Nishihara and T. Kyotani, "Zeolite-templated carbons – three-dimensional microporous graphene frameworks," *Chemical Communications*, vol. 54, no. 45, pp. 5648–5673, May 2018, doi: 10.1039/C8CC01932K.
6. H. Nishihara et al., "Graphene-based ordered framework with a diverse range of carbon polygons formed in zeolite nanochannels," *Carbon N Y*, vol. 129, pp. 854–862, Apr. 2018, doi: 10.1016/J.CARBON.2017.12.055.
7. H. Robson, K. P. Lillerud, and X. Patterns, *VERIFIED SYNTHESSES OF ZEOLITIC MATERIALS*, 2nd ed. 2016.
8. K. Jacob, J. Clement, M. Arockiaraj, D. Paul, and K. Balasubramanian, "Topological characterization and entropy measures of tetragonal zeolite merlinoites," *J Mol Struct*, vol. 1277, p. 134786, Apr. 2023, doi: 10.1016/J.MOLSTRUC.2022.134786.
9. Y. Wen et al., "Advances in hydrogen storage materials for physical H<sub>2</sub> adsorption," *Int J Hydrogen Energy*, vol. 97, pp. 1261–1274, Jan. 2025, doi: 10.1016/J.IJHYDENE.2024.11.459.
10. Z. Zijun, G. Effeney, G. J. Millar, and M. Stephen, "Synthesis and cation exchange capacity of zeolite W from ultra-fine natural zeolite waste," *Environ Technol Innov*, vol. 23, p. 101595, Aug. 2021, doi: 10.1016/J.ETI.2021.101595.



*Ariyo Hidayanto*  
*Synthesis & Screening Sodium Mordenite and Potassium Merlinoite Deposited Carbon [Na-MOR/C & K-MER/C] as Hydrogen Physisorbent*

17

## THANK YOU FOR YOUR ATTENTION

**MEK** 1735  
MISKOLCI EGYETEM  
MŰSZAKI FÖLD- ÉS  
KÖRNYEZETTUDOMÁNYI  
KAR

**FRESHWATER INTRUSION INTO PRAID SALT MINE  
FUTURE POSSIBILITIES**

*Kovács Balázs*  
egyetemi docens, assoc. prof.

MISKOLCI  
EGYETEM

MTA  
Kiváló Kutatóhely

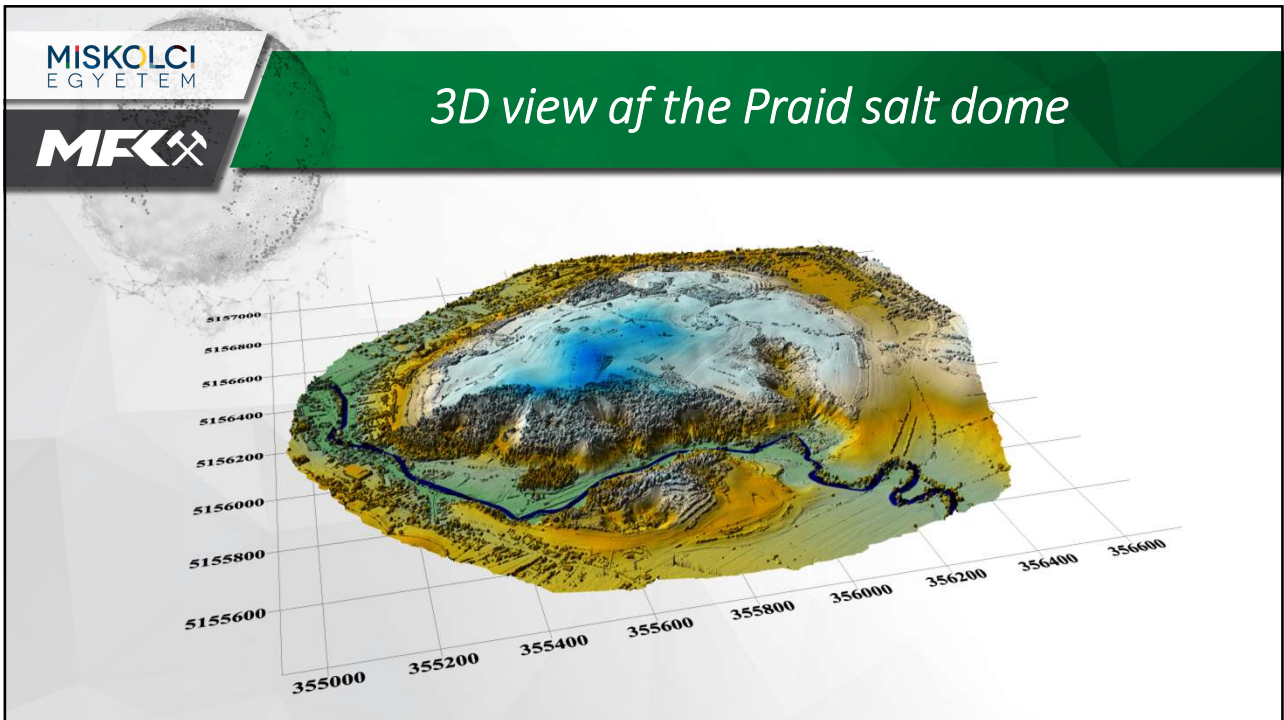



## Some facts

- A flood situation developed on the Corund Creek at the end of May 2025.
- Water flux 60 m<sup>3</sup>/s corresponds to a flood with a 10-year recurrence interval (10% - 60-70 m<sup>3</sup>/s, 1% - 200 m<sup>3</sup>/s)
- Small catchment area, stream with unpredictable and large amplitude flow fluctuations (Corund creek is 19.6 km long, with a catchment area of 137 km<sup>2</sup>; its average elevation is 780 m, its source is at 950 m, its mouth is at 471 m, and its average gradient is 24.7 m/km)
- On May 27, 2025, a powerful water intrusion into the so-called Parallel Mine from the direction of Salt Canyon
- On May 29, 2025, the entire underground mine system is flooded to a level of 477 m asl.



## The EU Civil Protection Mission

- June 2, 2025: Romania requests civil protection assistance from the EU (areas of expertise: mining - rock mechanics, groundwater (hydraulics), environmental protection)
- June 2-3, 2025: Member states nominate experts, Romania selects 8 people (Germany 2, Netherlands 1, Spain 1, Hungary 4)
- June 3, 2025: First online meeting and briefing for experts organized by the ERCC
- June 4, 2025: The mission begins its work on site in the evening
- June 10, 2025: The team presents its expert opinion to Romania
- June 17, 2025: The team prepares its nearly 80-page technical report



EU Civil Protection Team (CPT)

(EU CPT photos)

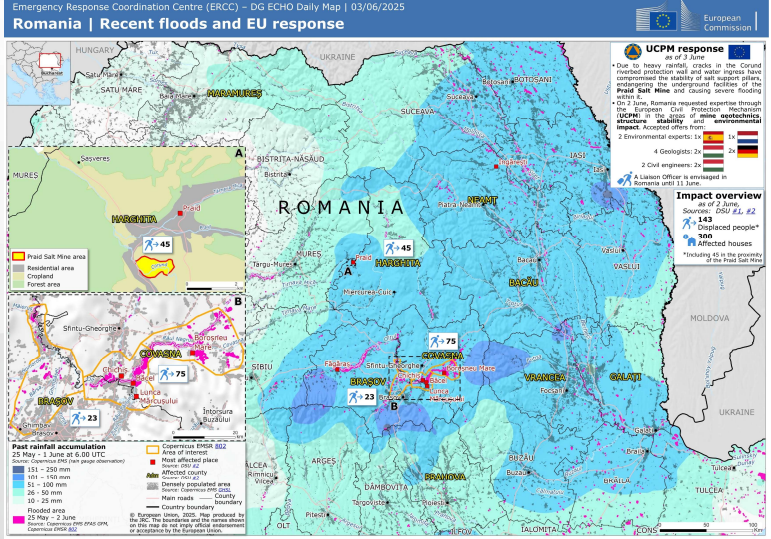

**Romania | Recent floods and EU response**

**UCPM response** as of 2 June

- Due to heavy rainfall, cracks in the ground riverbed protection wall and water ingress have compromised the stability of salt support pillars, endangering the underground facilities of the **Praid Salt Mine** and causing severe flooding.
- On 2 June, Romania requested expertise through the European Civil Protection Mechanism (UCPM) in the areas of mine geotechnics, hydrogeology, and environmental monitoring.

**Impact overview** (Source: DSU ZL #2)



- 143 Displaced people\*
- 160 Affected houses
- \*Thinking it is the capacity of the Praid Salt Mine

**Past rainfall accumulation** 25 May - 1 June at 6:00 UTC

- 151 - 250 mm
- 101 - 150 mm
- 51 - 100 mm
- 26 - 50 mm
- 10 - 25 mm

**Flooded area** 25 May - 2 June

**Legend:** Praid Salt Mine area, Residential area, Cropped area, Forest area, Contaminated area, Area of interest, Road affected area, Damaged populated area, Heavy roads, Country boundary, Country boundary



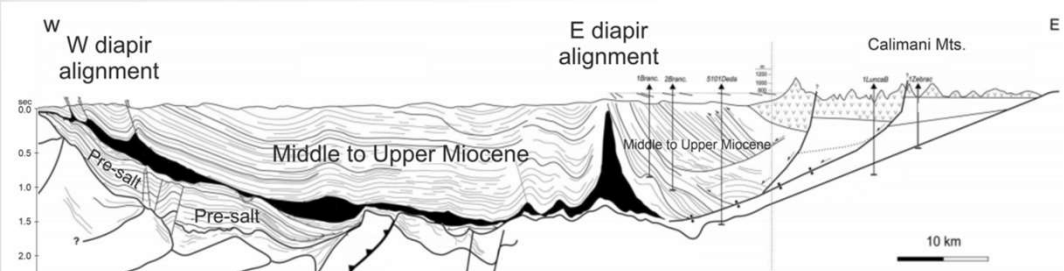

Some Geology

- The Transylvanian Basin was separated from the Thethys Sea 20-22 million years ago
- Evaporites are deposited on clay layers due to strong evaporation
- The basin sinks rapidly: 5000 m thick sediment is deposited on it, exerting great pressure on the salt deposits
- Under high pressure, the salt is pressed towards the edges of the basin as a viscous fluid
- Along the tectonic lines, it breaks through to the surface
- It either remains trapped deep underground (cryptodiapir) or pushes its way to the surface (diapir)

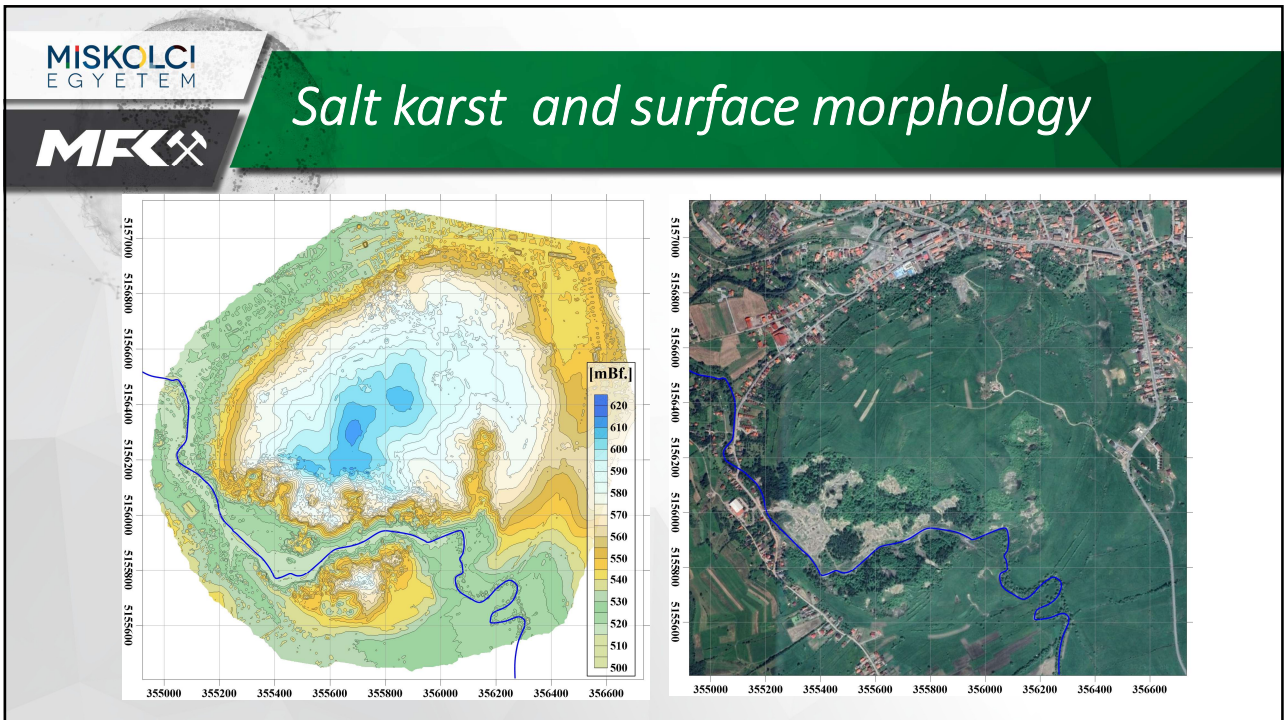
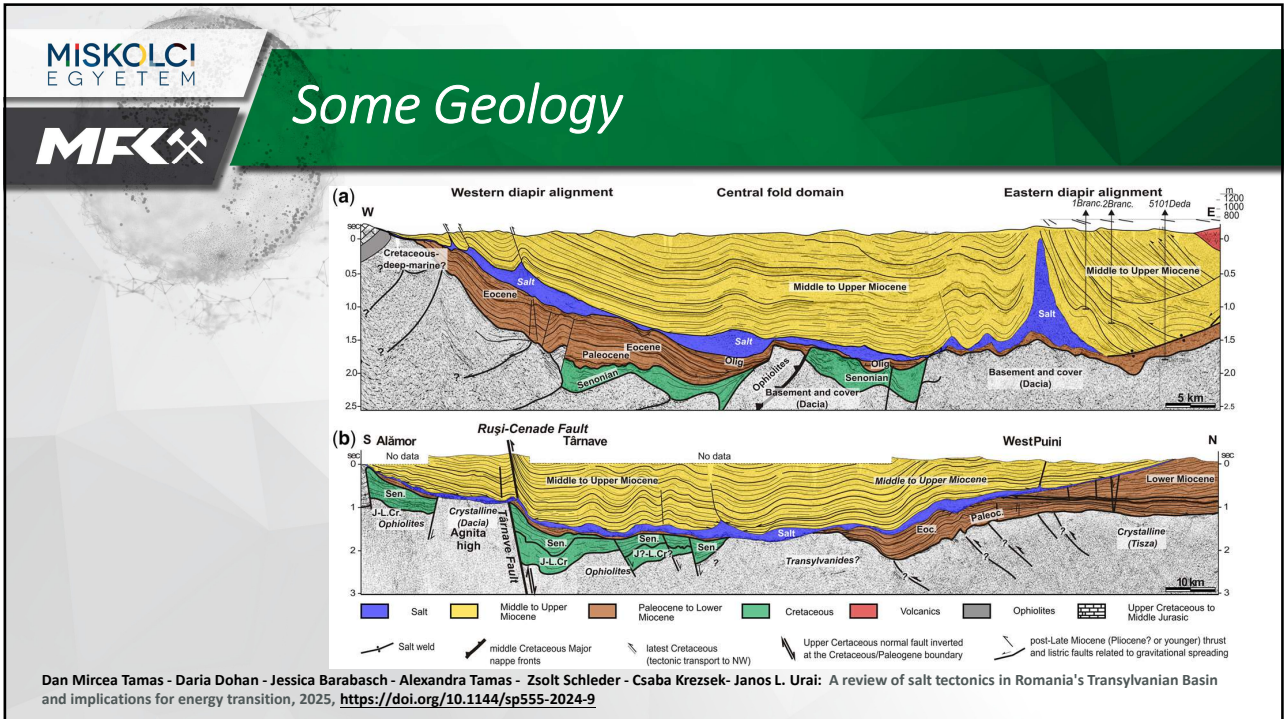

Gelencsér, O., Szakács, A., Gál, Á. *et al.* Microstructural study of the Praid Salt Diapir (Transylvanian basin, Romania) and its implication on deformation history and hydrogen storage potential. *Acta Geod Geophys* **59**, 343–365 (2024).



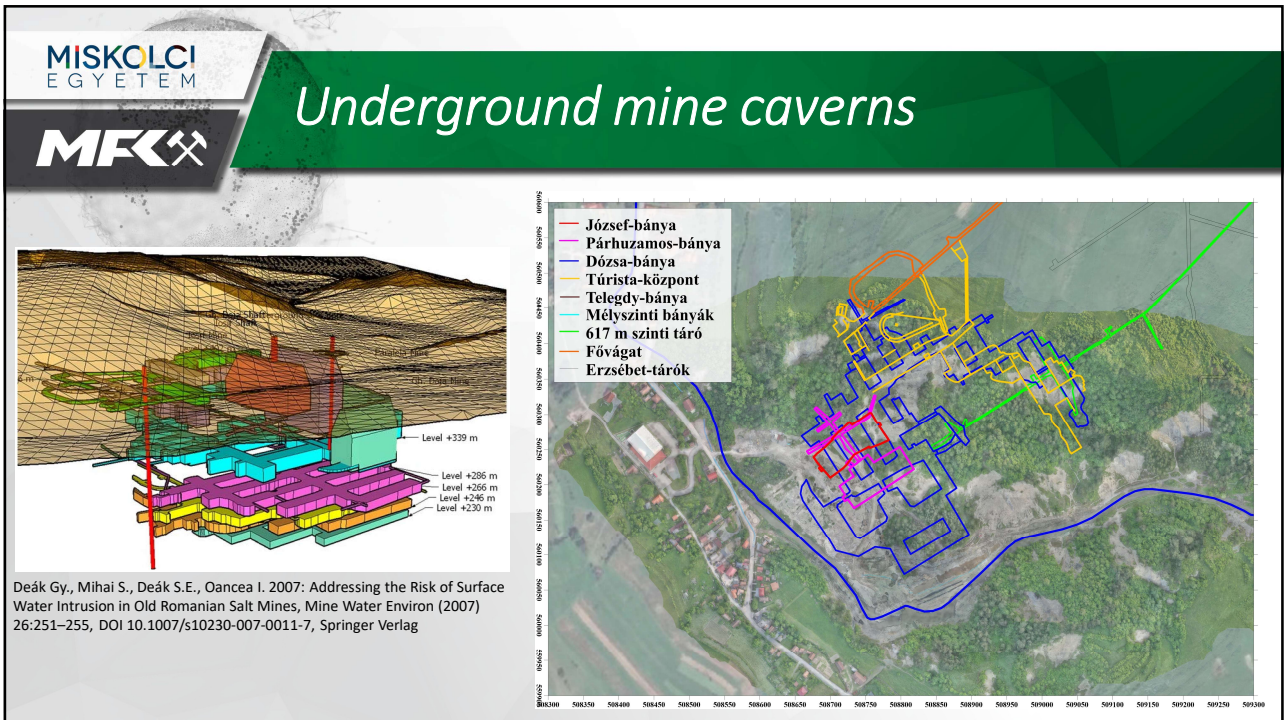
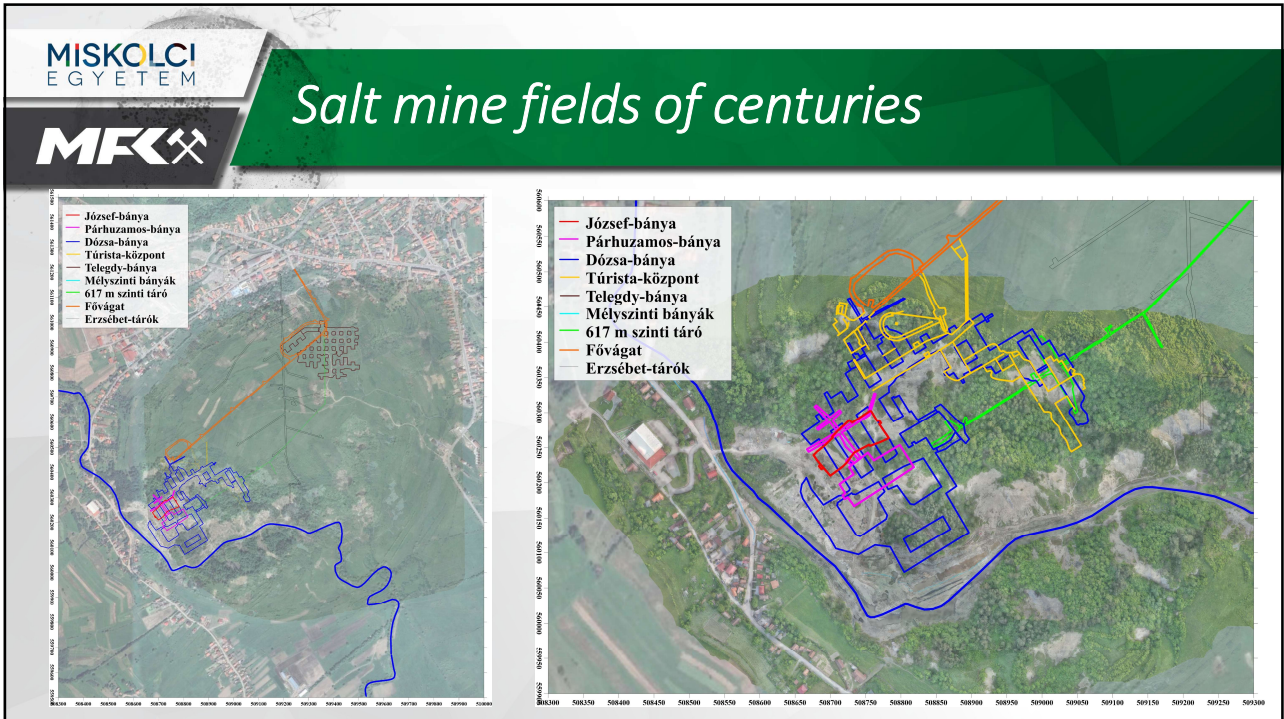

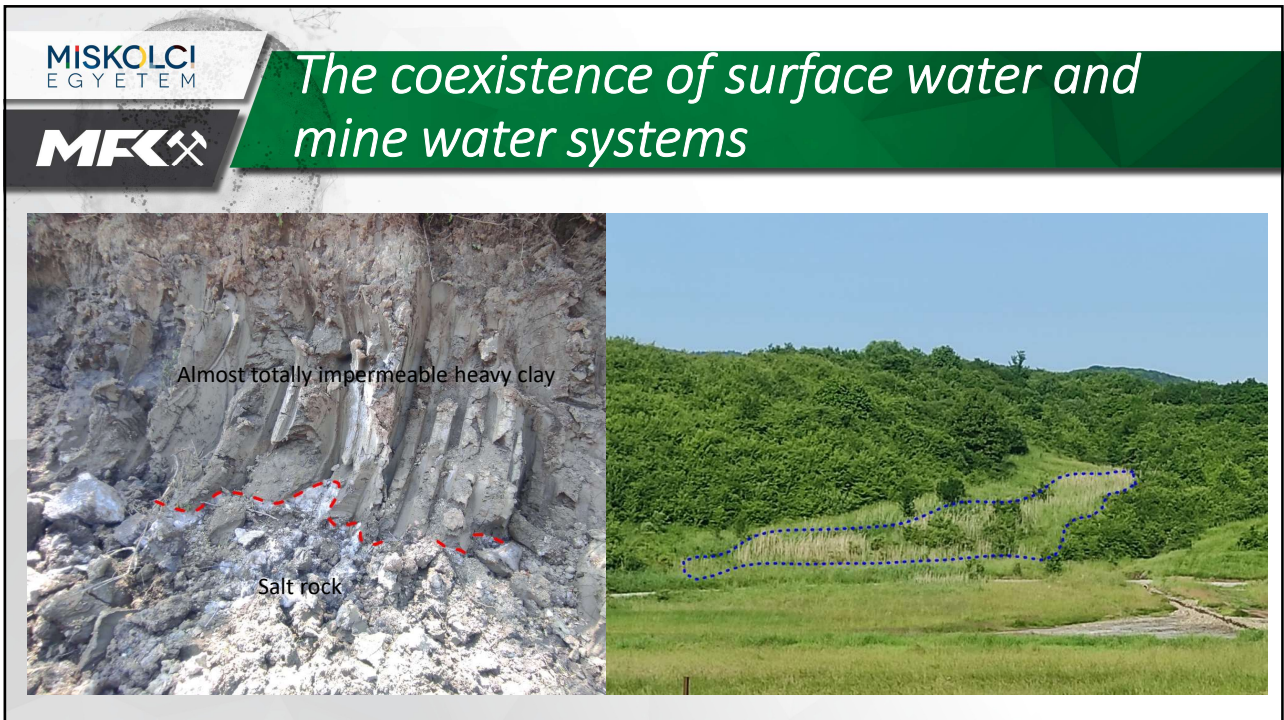
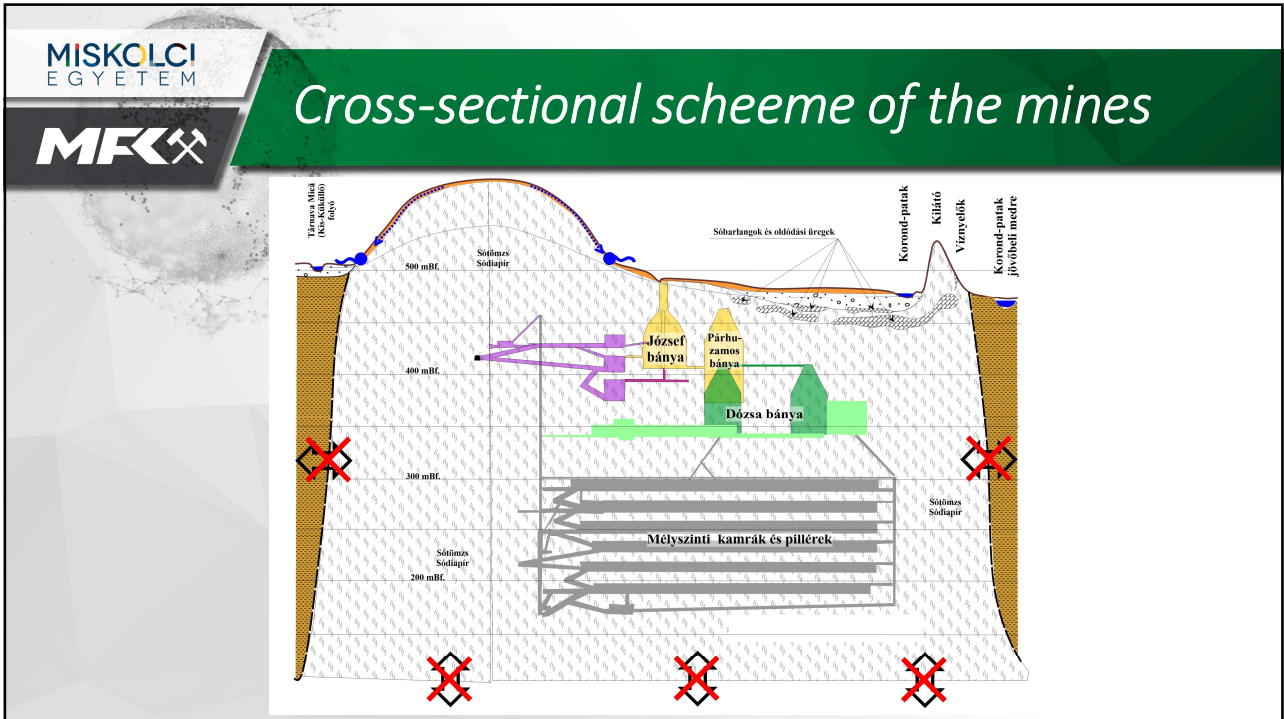

MISKOLCI EGYETEM

**MFK**

# What happened?



[https://cdn.szekelyhon.ro/vasarhely/aktualis/2025/08-majus/nn\\_parajd-majus-28-07-hv.jpg](https://cdn.szekelyhon.ro/vasarhely/aktualis/2025/08-majus/nn_parajd-majus-28-07-hv.jpg)

© Szekelyhon.ro

MISKOLCI EGYETEM

**MFK**

# What happened?





[https://cdn.szekelyhon.ro/vasarhely/aktualis/2025/08-majus/nn\\_parajd-majus-28-07-hv.jpg](https://cdn.szekelyhon.ro/vasarhely/aktualis/2025/08-majus/nn_parajd-majus-28-07-hv.jpg)

© Szekelyhon.ro

MISKOLCI EGYETEM

MFK

# What happened?

VIZITĂ-FULGER LA SALINA PRAID

© Szekelyhon.ro

[https://cdn.szekelyhon.ro/vasarhely/aktualis/2025/08-majus/nn\\_parajd-majus-28-07-hv.jpg](https://cdn.szekelyhon.ro/vasarhely/aktualis/2025/08-majus/nn_parajd-majus-28-07-hv.jpg)

MISKOLCI EGYETEM

MFK

# What happened?

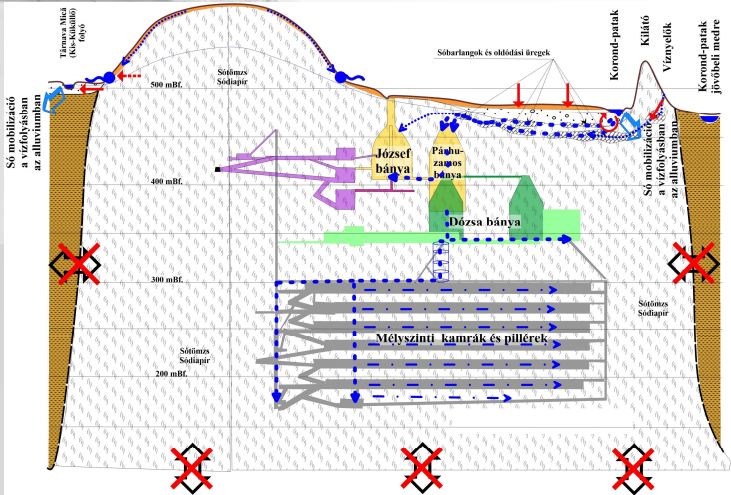

Based on the mine sketch of Szilámér J. Kovács (SALROM)



(EU CPT photo)

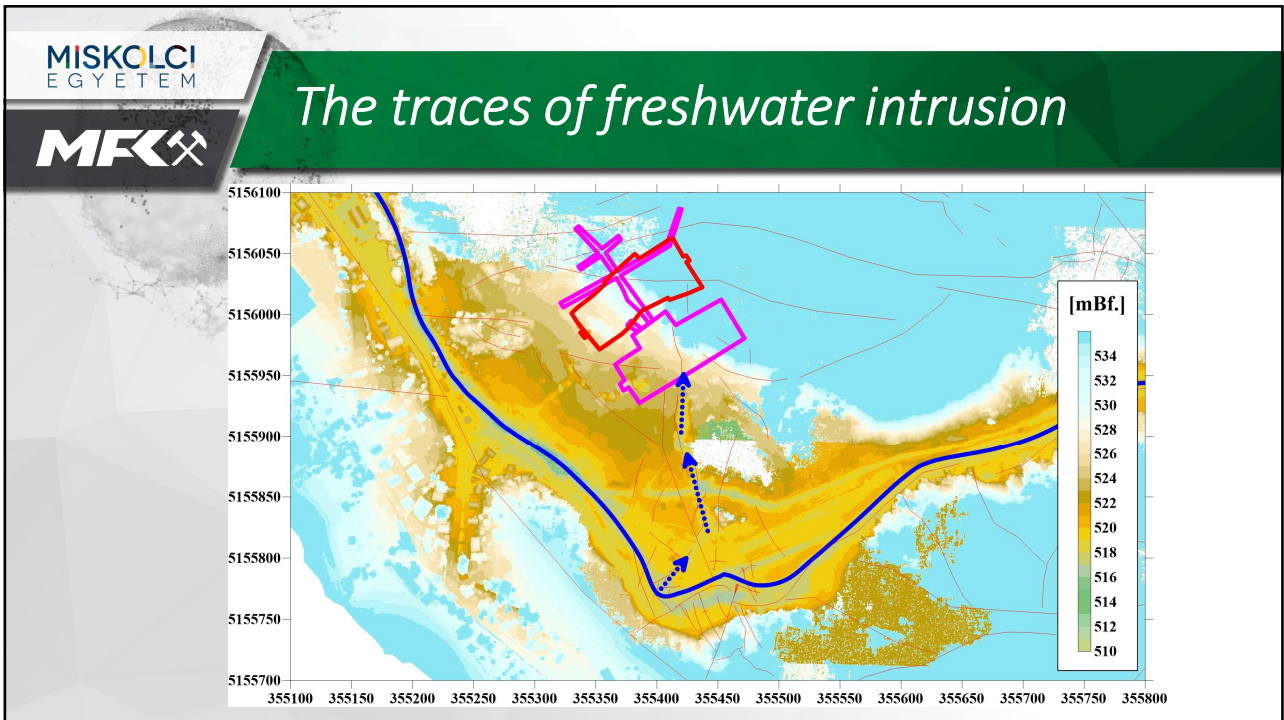
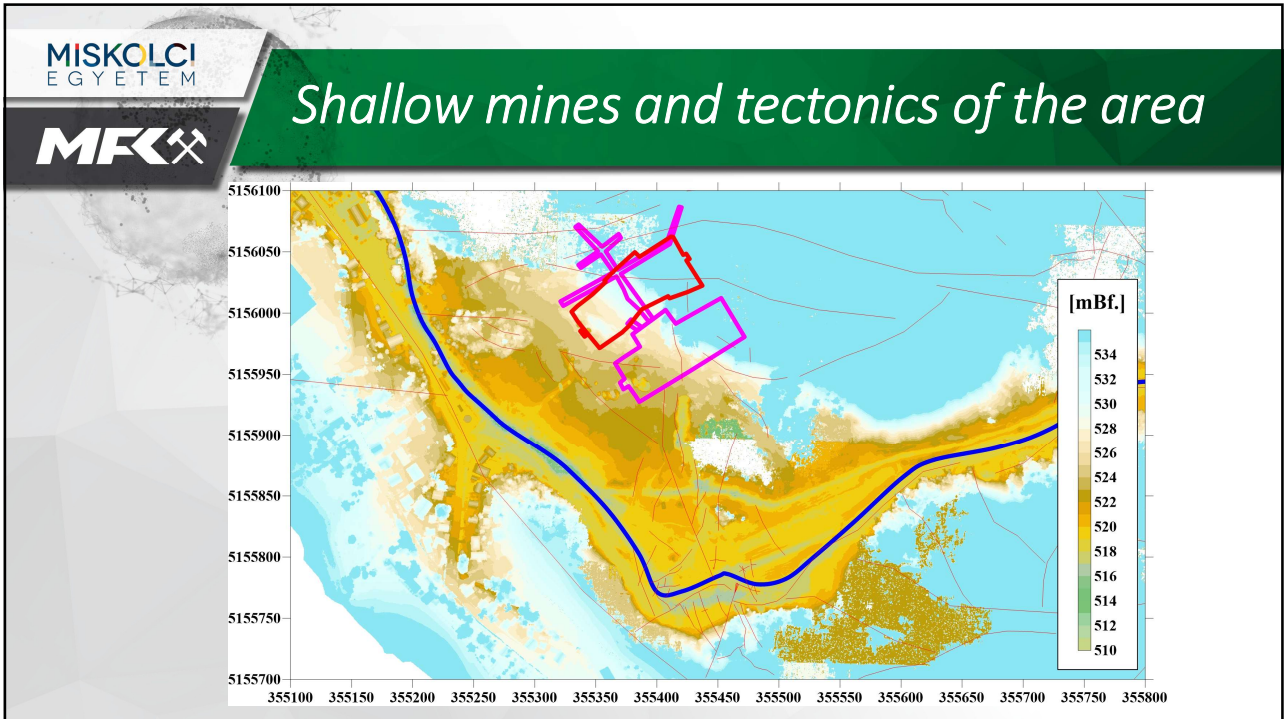

MISKOLCI EGYETEM

MFK

## Surface subsidences just after the flood

03.06.2025

07.06.2025

© BGR, Benedikt Preugschat

(Source: EU CPT presentation of the final report)

MISKOLCI EGYETEM

MFK

## Surface subsidences just after the flood

Vertical shaft Josp Mine

Vertical shaft Parallel Mine

(Source: EU CPT presentation of the final report)

(EU CPT photos)

MISKOLCI EGYETEM

MFK

## Before and after



June 7, 2025

June 11, 2025

(EU CPT photos)

MISKOLCI EGYETEM

MFK

## Building a temporary bypass on the creek

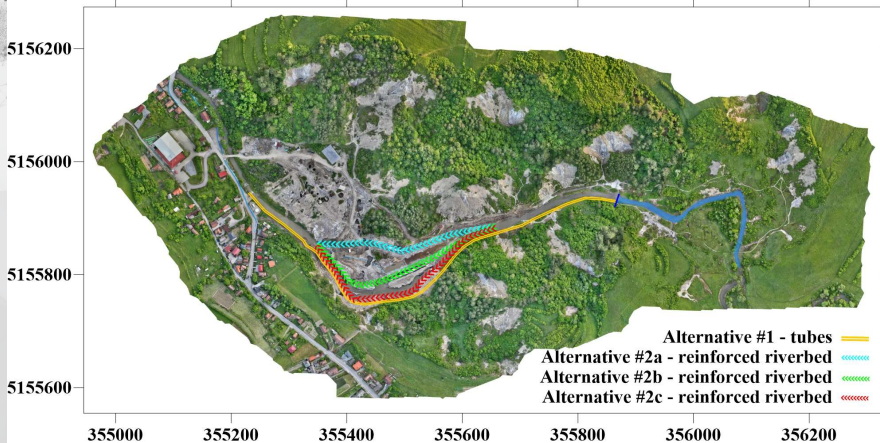

Alternative #1 - tubes

Alternative #2a - reinforced riverbed

Alternative #2b - reinforced riverbed

Alternative #2c - reinforced riverbed

(Source: EU CPT presentation of the final report)

MISKOLCI EGYETEM  
MFK

## Construction of the tube system

(EU CPT photo)

Corand-creek streamflow route

MISKOLCI EGYETEM  
MFK

## Alternative solution: building a temporary riverbed

strap

strap

Openings filled with concrete & holes patched

DECOMMISSIONED PIPELINE

Max. WL

Height safety 25 cm

optional concrete blanket

1,5 m

B=12,0 m

concrete injecting

current river bed

1:1,5

1:1,5

(Source: EU CPT presentation of the final report)



**MISKOLCI EGYETEM**



## Comparison of solutions

Problem class	Altern. #1 Tubes	Altern. #2 Riverbed	Problem class	Altern. #1 Tubes	Altern. #2 Riverbed
Length	As you like ✓	As you like ✓	Operational interval >3yrs	✓	✓
Yield [m3/d]	18-24 ?*	35 ?*	Costs	?✓	?*
Sensitivity to sinkholes	✓	✗	Future expandability	?*	?✓
Sensitivity to landslides	✗	✓	Future reparability	✓	✓
Sensitivity to land subsidences	✗	?	Sensitivity to corrosion	✗	✓
Sensitivity to curves	✗	✓	Effects on salt karst /Env. risks	✗	-
Sensitivity to tensile stresses	✗	✓	Risk of ruin (collapse)	?*	?*
Cleanability	?✓	✓	Need of river bypass during construction	✗	✓
Sensitivity to debris and float scum	?	✓			

(Source: EU CPT presentation of the final report)

Legend: ? – Questionable    ✓ - Good solution    ✗ - Problematic issue exist



**MISKOLCI EGYETEM**



## Recent situation

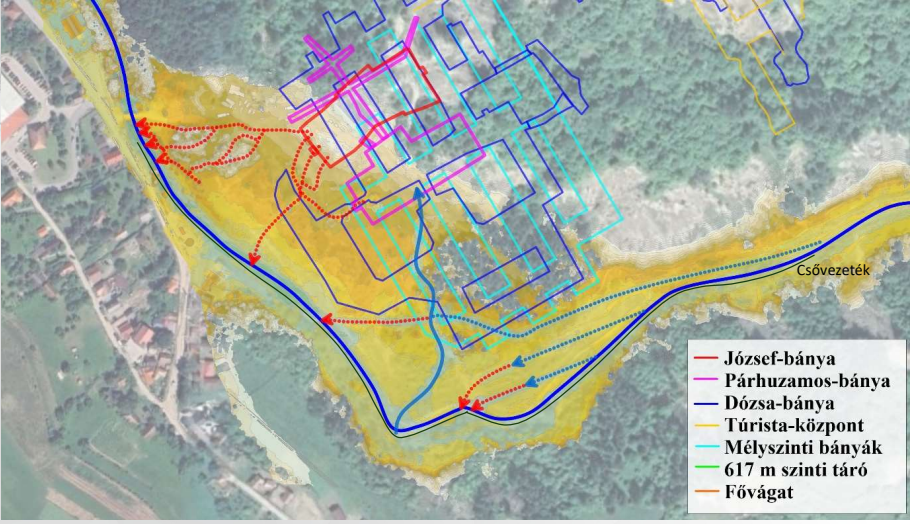

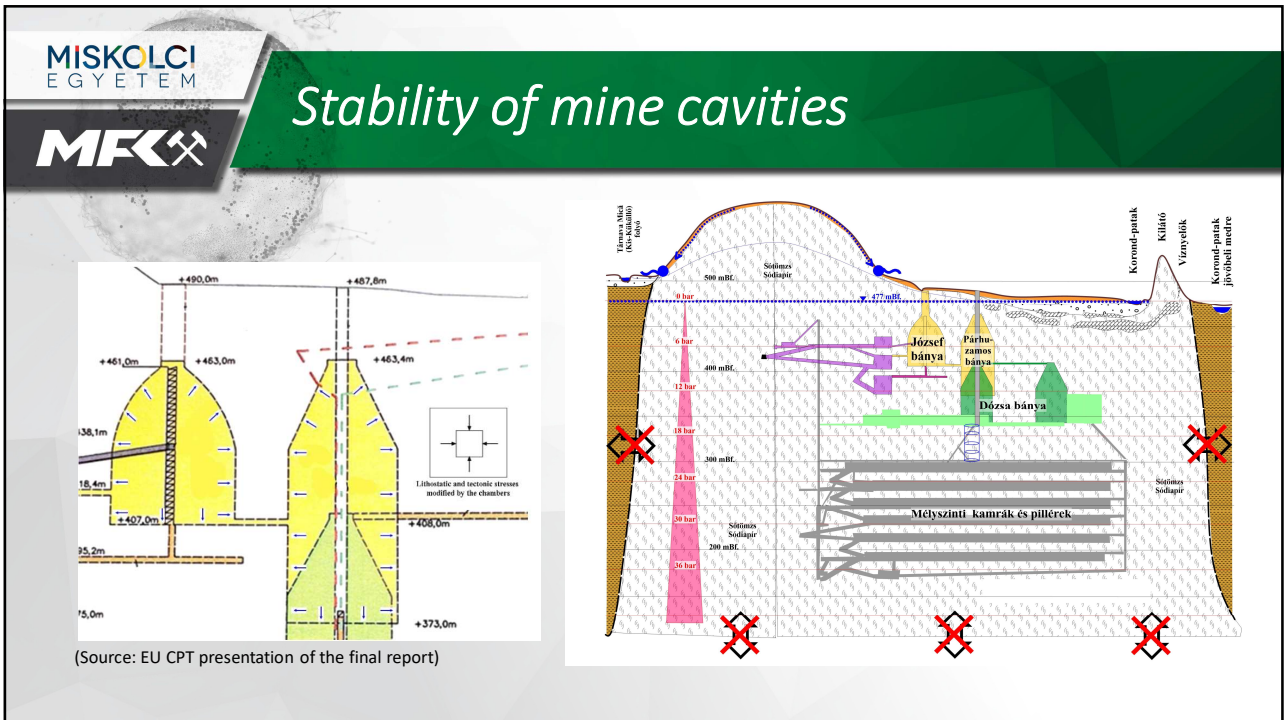
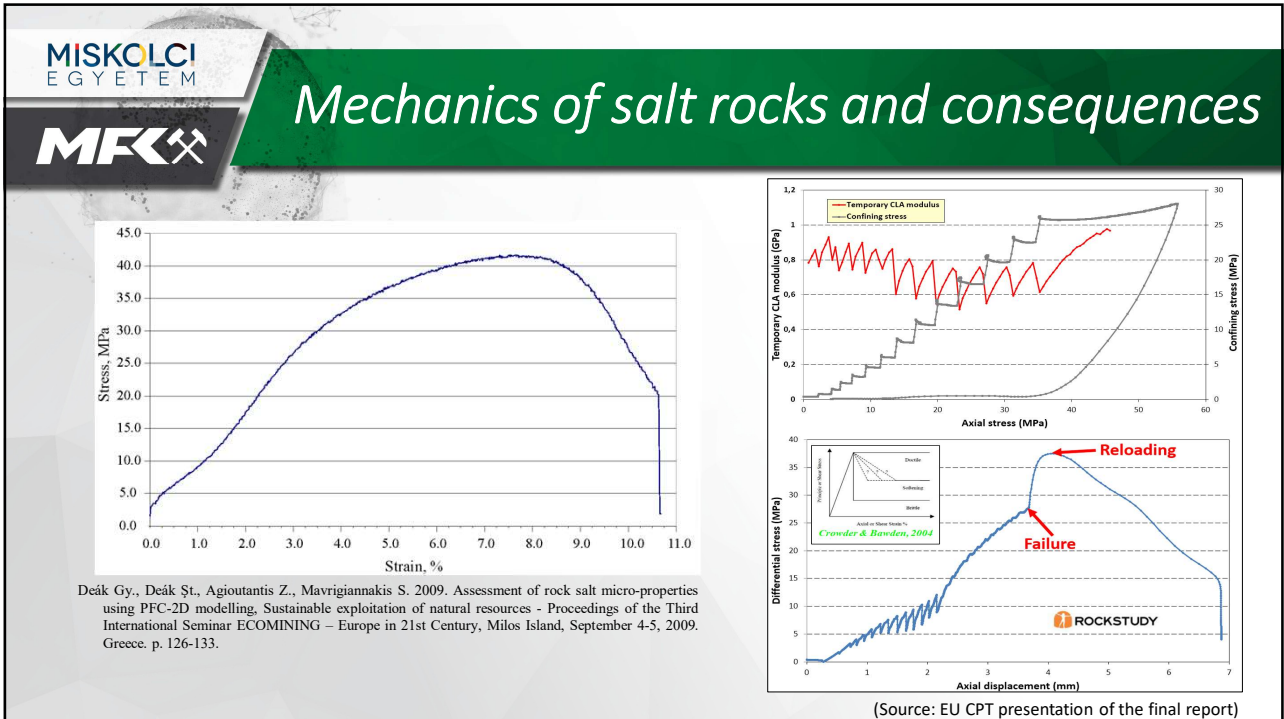

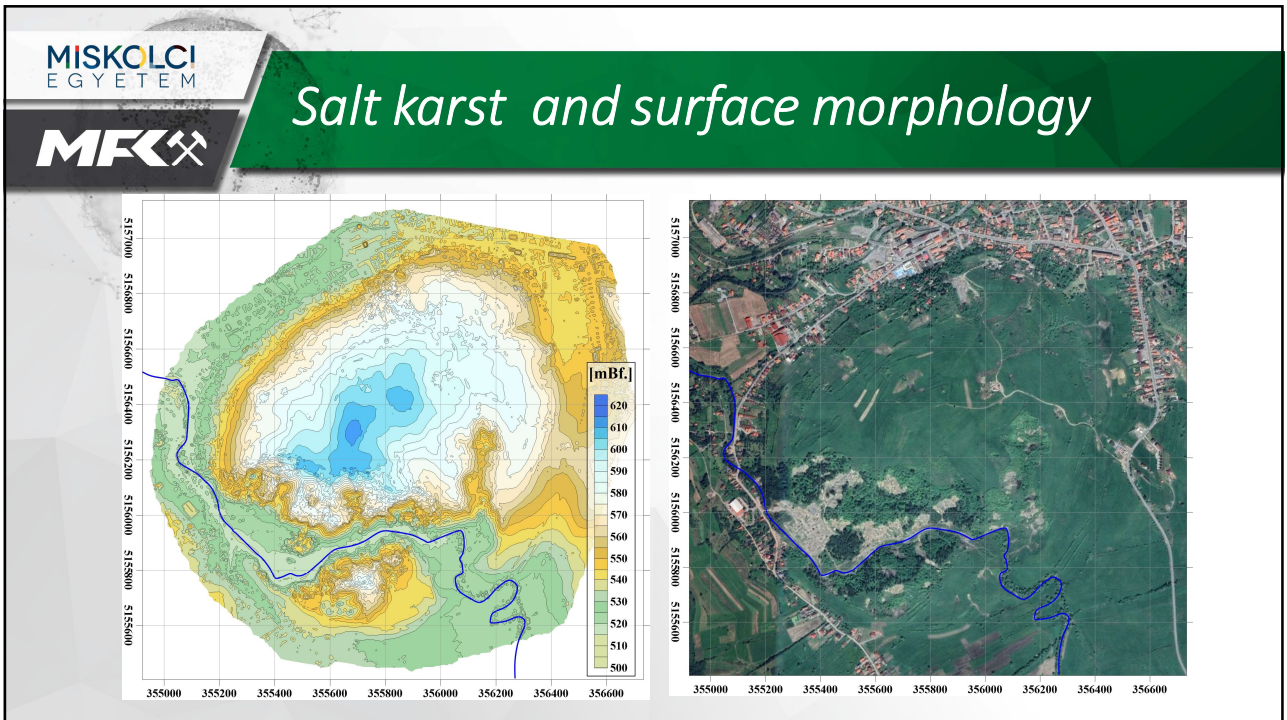
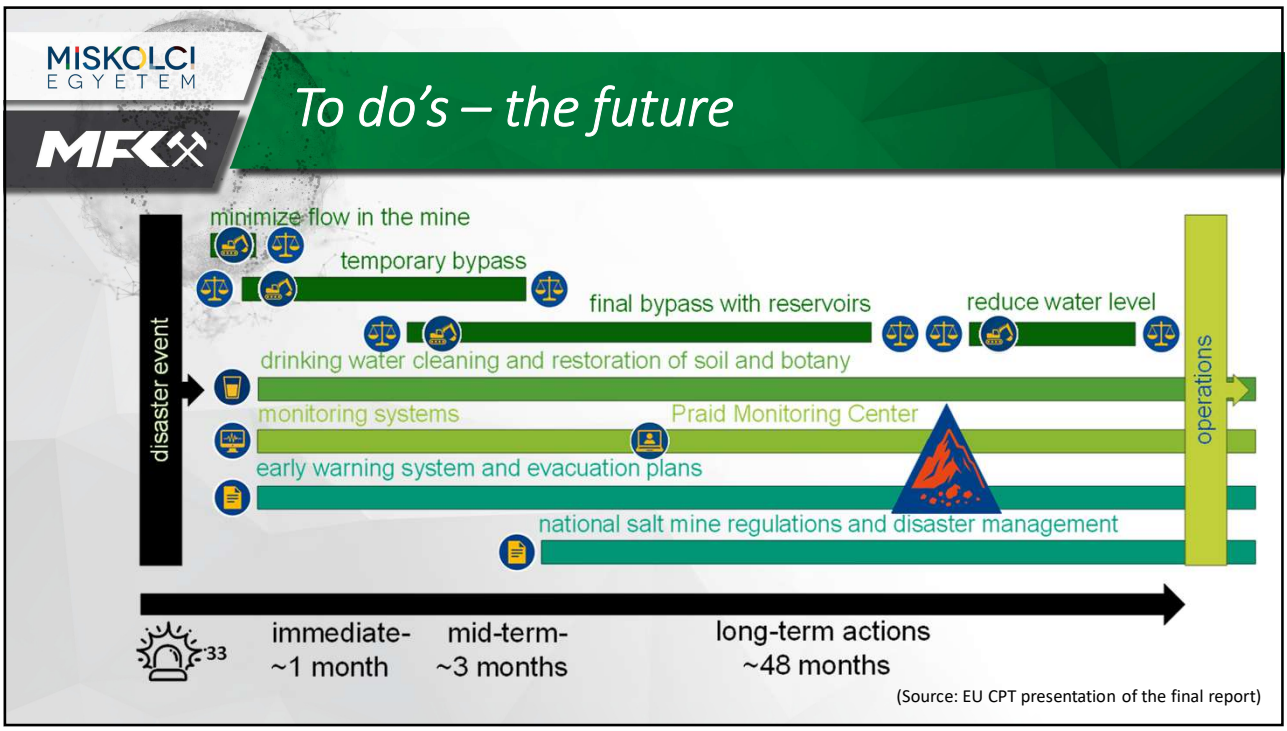





The image features the logo of Mangosuthu University of Technology (MUT) on the left, which includes a stylized graphic of a curved line and a zigzag pattern with colored diamonds. Below the logo, the text 'MUT' is written in a large, bold, sans-serif font, followed by 'MANGOSUTHU' and 'UNIVERSITY OF TECHNOLOGY' in smaller fonts. To the right of the logo, the title 'Development of an Integrated Urban Water System to Mitigate Climate Change Impacts in Local Communities' is written in a bold, black, sans-serif font. Below the title, the author's name 'Thobeka Makhathini (PhD)' and the department 'Department of Chemical Engineering' are listed. On the right side of the slide, there is a decorative graphic consisting of several overlapping, semi-transparent geometric shapes in shades of red, blue, and yellow.

## OUR MISSION AND VISION STATEMENT



### Mission Statement

To offer technological career directed educational programmes, focusing on innovative problem solving research and engage with government/business/industry and communities as end users.

### Vision Statement

To be a transforming, equitable, sustainable and academically excellent University of Technology anchored in its communities.



**MUT** MANGOSUTHU  
UNIVERSITY OF TECHNOLOGY

## Background & Motivation



Climate change intensifies urban water challenges



Durban's townships face flooding, droughts, and infrastructure collapse



Need for resilient, inclusive water systems



**MUT** MANGOSUTHU  
UNIVERSITY OF TECHNOLOGY

## Project Objectives

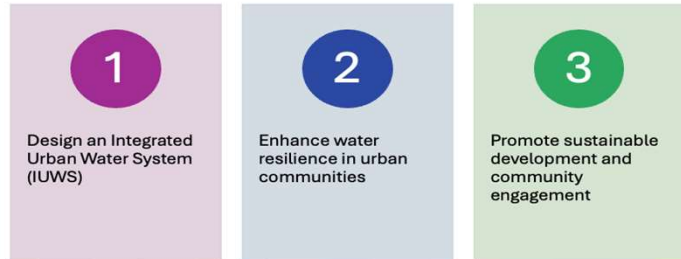

## Study Area

- Informal settlement with ~480 households
- Vulnerable to water scarcity and flooding
- Socio-economic factors limit access to clean water

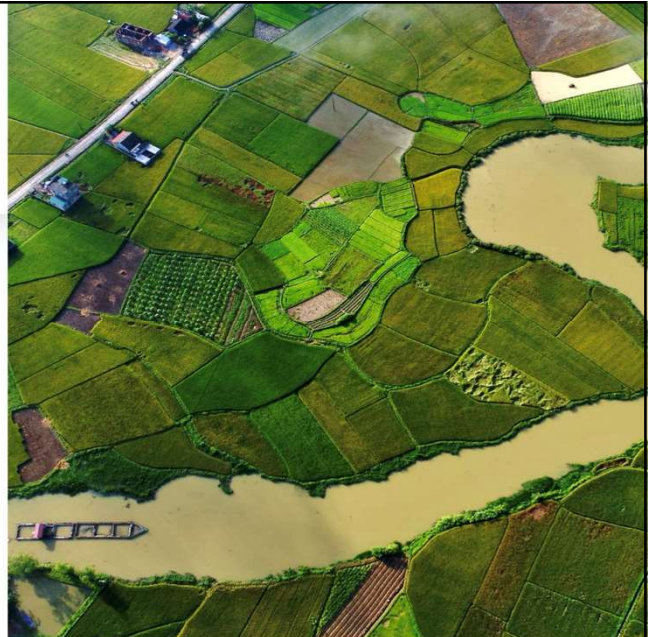

# Study Design & Approach



Design: Mixed-methods systems approach combining hydrological & hydraulic modelling, supply-network simulation, spatial analysis, cost-benefit appraisal and participatory action research with communities and municipal actors.



Theory of change: Build shared understanding of climate risks in eThekweni → co-design integrated interventions (supply, demand, blue-green infrastructure, reuse) → pilot solutions in representative wards → monitor, refine, and produce municipal adoption roadmap.



## Literature insights

01

Fragmented water systems increase vulnerability

02

IUWS integrates supply, sanitation, stormwater, and reuse

03

Global best practices inform local adaptation



## Challenges in South African townships

---



## Traditional vs Integrated Approaches

---





<b>Traditional Approach</b>	<b>IUWS Approach</b>
Siloed management	Holistic integration
Centralised systems	Decentralised reuse
Limited community input	Participatory planning



## Proposed IUWS model



## Implementation Roadmap

-  Stakeholder Engagement
-  Policy Reform
-  Capacity Building
-  Funding Mechanisms
-  Monitoring & Evaluation



## Case Examples



Cape Town's post-Day Zero innovations



eThekweni's DEWATS pilot projects



Lessons from Windhoek and Nairobi



**MUT** MANGOSUTHU  
UNIVERSITY OF TECHNOLOGY

## Barriers to implementation

- Institutional fragmentation
- Funding constraints
- Technical capacity gaps
- Community trust and behavior change

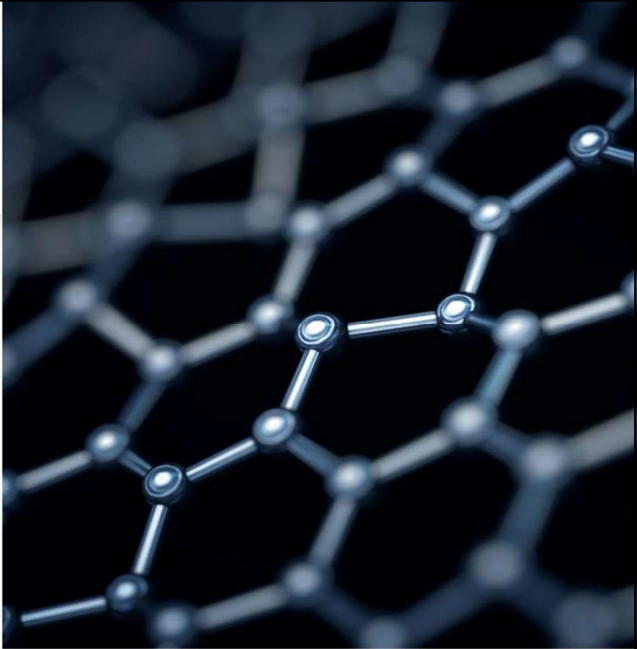

**MUT** MANGOSUTHU  
UNIVERSITY OF TECHNOLOGY

## CONCLUSION

IUWS offers a resilient, inclusive solution

Requires systemic change in governance and planning

Empowers communities to adapt and thrive



Thank You!!!

EXCELLENCE IN RESEARCH, INNOVATION AND ENGAGEMENT



EXCELLENCE IN COMMUNITY ENGAGEMENT

EXCELLENCE IN TEACHING AND LEARNING

TO CREATE AN ENABLING SUPPORT ENVIRONMENT

TARGETED NATIONAL AND INTERNATIONAL ENGAGEMENT

**MUT**  
MANGOSUTHU  
UNIVERSITY OF TECHNOLOGY  
[www.mut.ac.za](http://www.mut.ac.za)







## Integrated Assessment of Groundwater Salinity Sources and Inter-Aquifer Mixing Dynamics in Siwa Oasis, Egypt: A Multi-Method Approach Using Self-Organizing Maps, Isotopic Tracers, and Numerical Modeling

**Mohamed Hamdy Eid Hemida**  
Ph.D. Candidate



**Scientific Supervisors:**  
Prof. Dr. Péter Szűcs  
Dr. Attila Kovács

## Study Area Description (Siwa Oasis)

### Geographical & Geological Setting

- 📍 Western Desert of Egypt, 300 km south of the Mediterranean Sea and 800 km from the Nile River
- 💧 **Water resources and aquifer system**

**Tertiary Carbonate Aquifer (TCA)**

- 🏗️ Upper aquifer composed of limestone and dolomite
- 💧 Moderate to high salinity (1,500-24,000 mg/L TDS) → irrigation

**Nubian Sandstone Aquifer (NSSA)**

- 🏗️ Deep aquifer composed of sandstone with shale intercalations
- 💧 Lower salinity (< 50 mg/L TDS) → irrigation & drinking

- 🌊 Salt lakes (TDS: 60-150,000 mg/L) → not suitable for aquatic life
- 🌊 Springs (TDS: 1400-16,000 mg/L) → irrigation

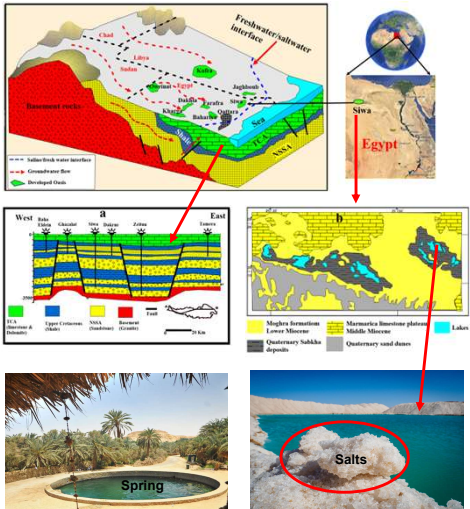

The figure includes a geological cross-section (a) showing the Tertiary Carbonate Aquifer (TCA) and Nubian Sandstone Aquifer (NSSA) with a freshwater-saltwater interface. It also features a map of Egypt (b) with Siwa Oasis highlighted, a detailed geological map (c) showing various rock formations like Upper Carbonate, NSSA, and Recent Quaternary, and a photograph (d) of a salt lake with a red circle highlighting the white salt deposits. A photograph of a spring is also included.

UNIVERSITY OF  
**MISKOLC**  
HUNGARY

**MFK**

## Research Objectives & Motivation

**Aquifer connectivity and recharge mechanisms**

**Groundwater salinization origin of the TCA**

**Delineate the agricultural land deteriorated from increasing the Salt lakes**

**Delineate the Water logging zone and determine the reason**

**Delineate the Soil salinization area and the source of salinization**

High Evaporation rates ( 16.8 mm/day) and negligible precipitation (10 mm)

1. Recharge source of the aquifer system?
2. Connectivity between the TCA and NSSA?
3. Fractures and faults controlling groundwater flow?
4. Groundwater salinization source?
5. Soil salinization source ?
6. Water logging source?
7. Salt lakes not suitable for aquatic life? Risk of salt lakes?
8. Sustainability of water resources?
9. Water management plan?

UNIVERSITY OF  
**MISKOLC**  
HUNGARY

**MFK**

## Workflow of the research work

```

graph TD
    DC[Data collections] --> GP[Geophysical]
    DC --> HC[Hydrochemical]
    DC --> RS[Remote sensing]
    DC --> WLD[Water level and discharge rate]
    DC --> PT[Pumping test]

    GP --> WL[Well logs]
    GP --> AM[Aeromagnetic]
    WL --> GR[GR, SP, And R]
    AM --> GM[Gravity & Magnetic]

    HC --> PH[Physical]
    HC --> CH[Chemical]
    HC --> IS[Isotopes]
    PH --> PHT[PH, T, EC, and TDS]
    CH --> MI[Major ions Heavy metals]
    IS --> SI[Stable isotopes 18O, 2H, 87/86Sr, and 13C]
    IS --> RC[Radiocarbons 14C]

    RS --> L[ Landsat 8 & 5 ]

    WLD --> NSSA[NSSA]
    WLD --> TCA[TCA]
    WLD --> SPR[Springs]

    PT --> PT
    
```

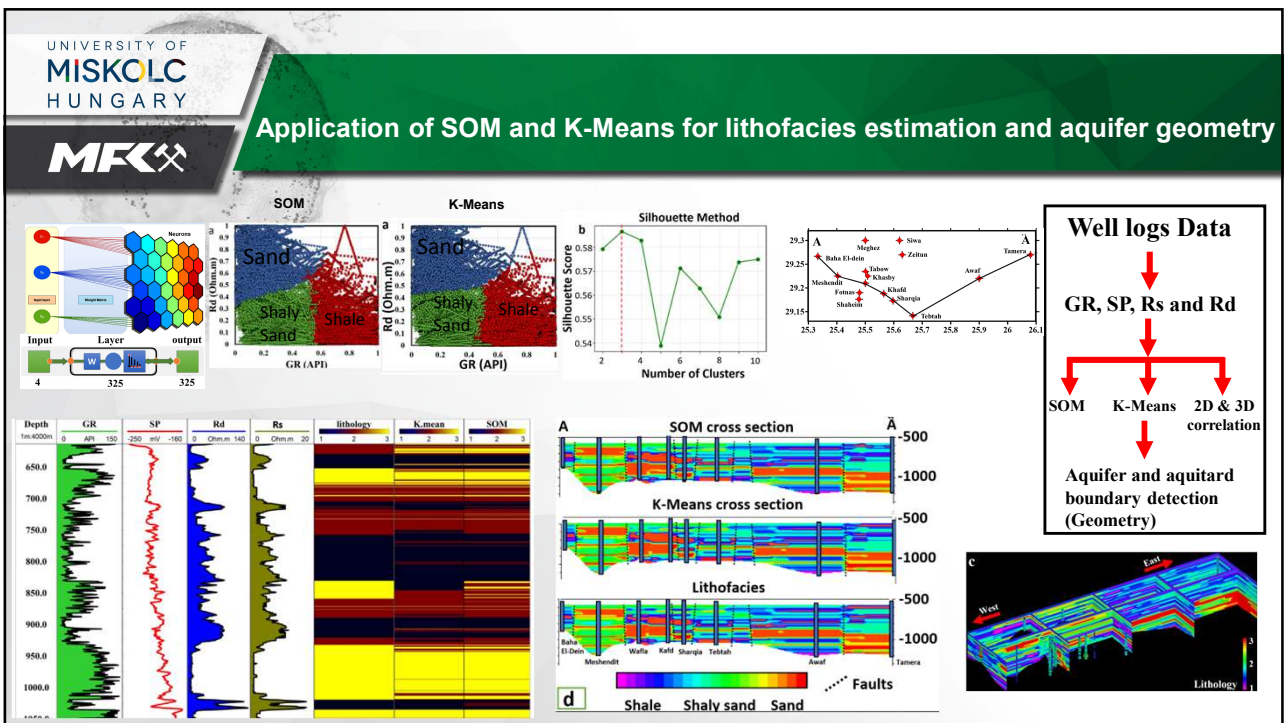
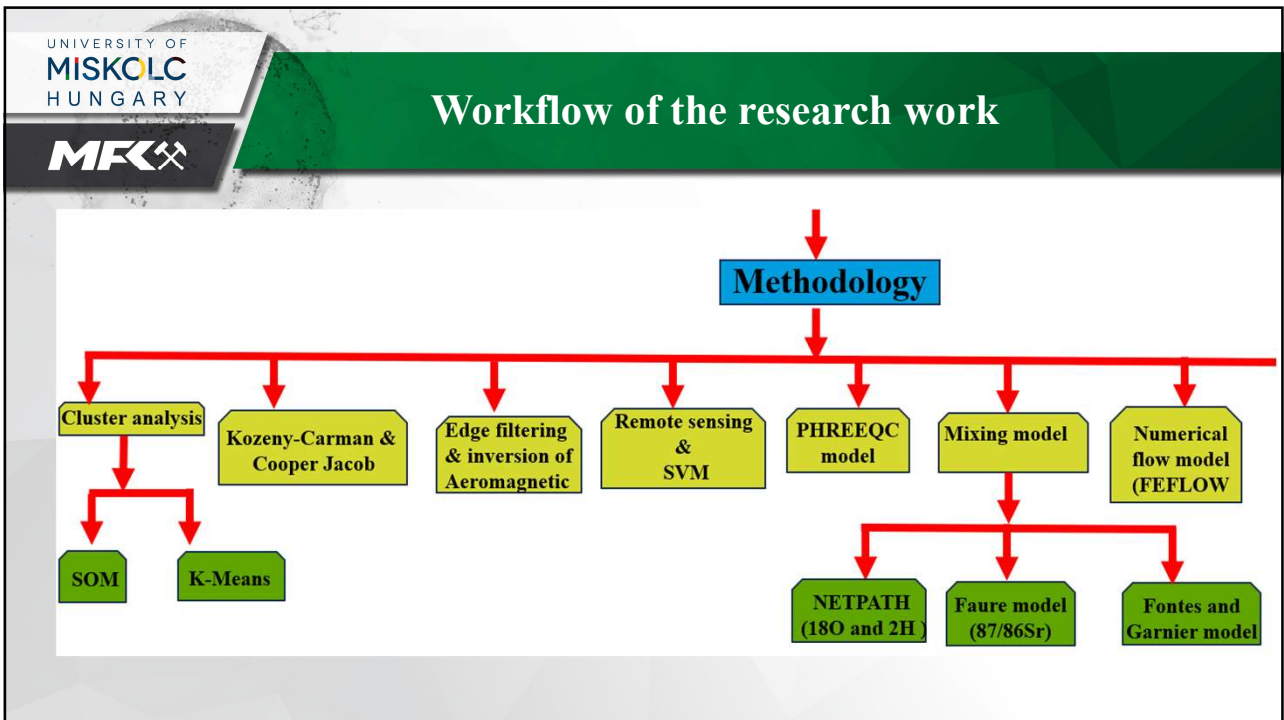

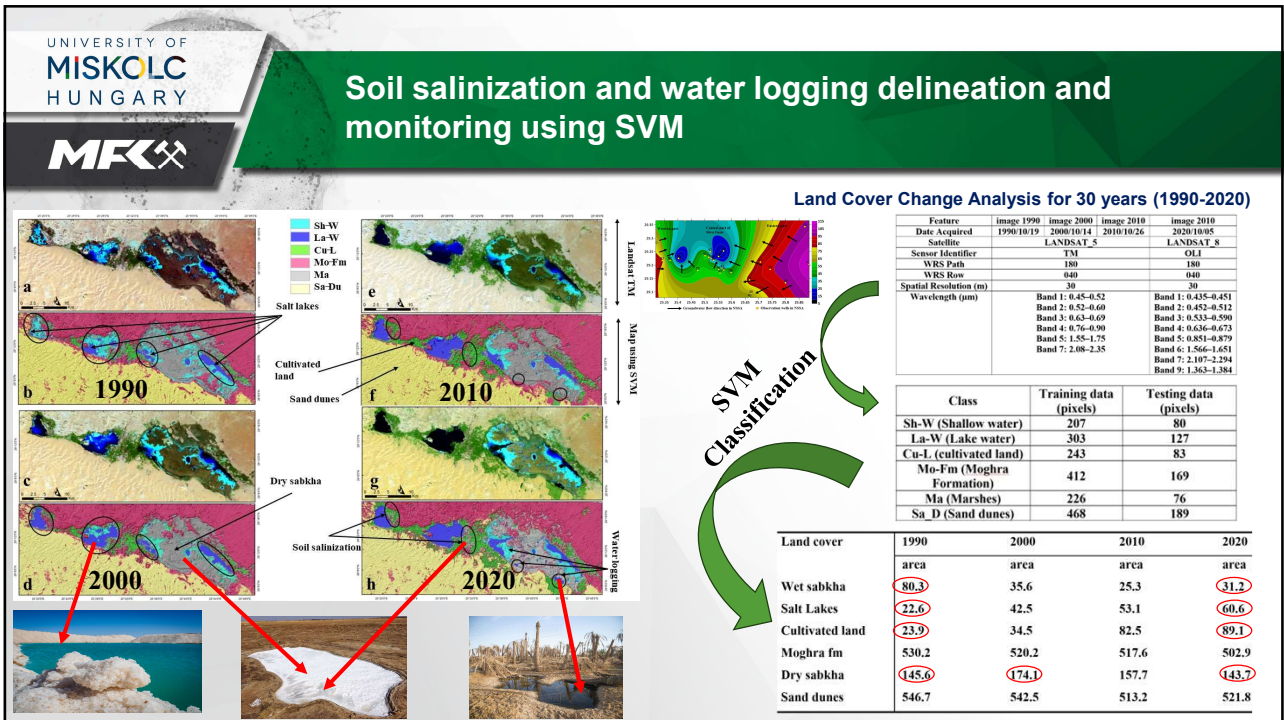
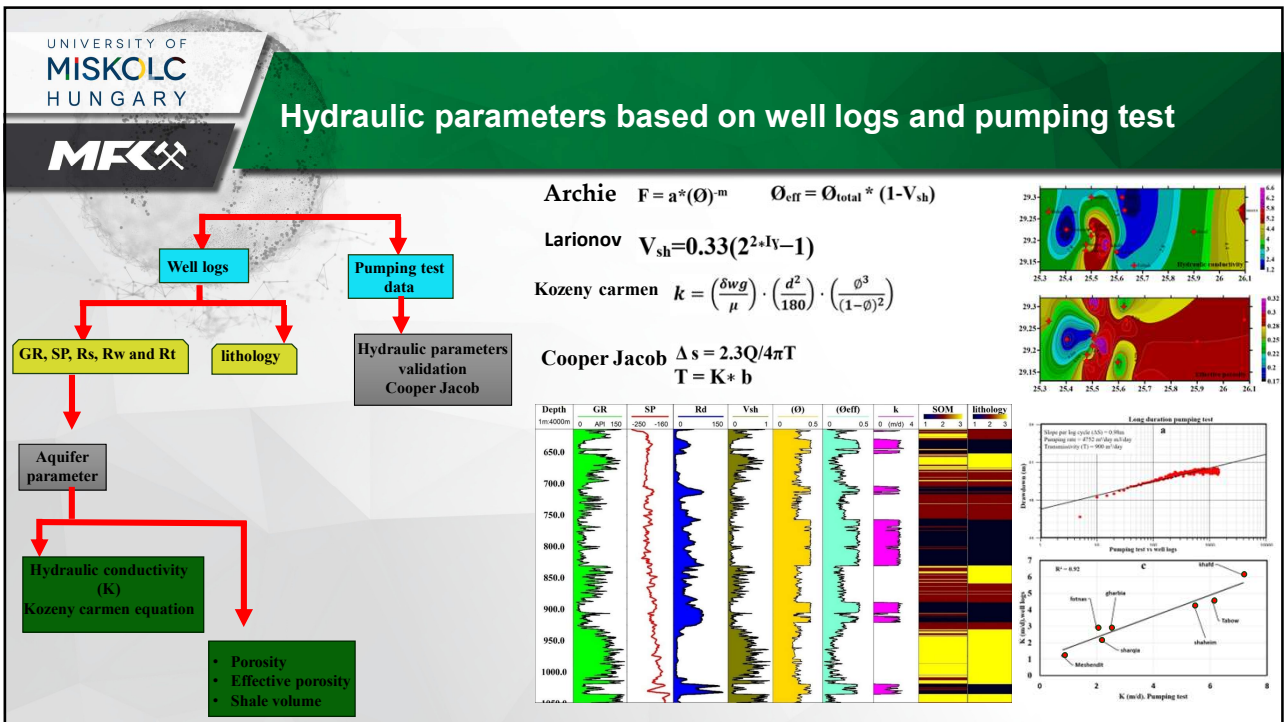

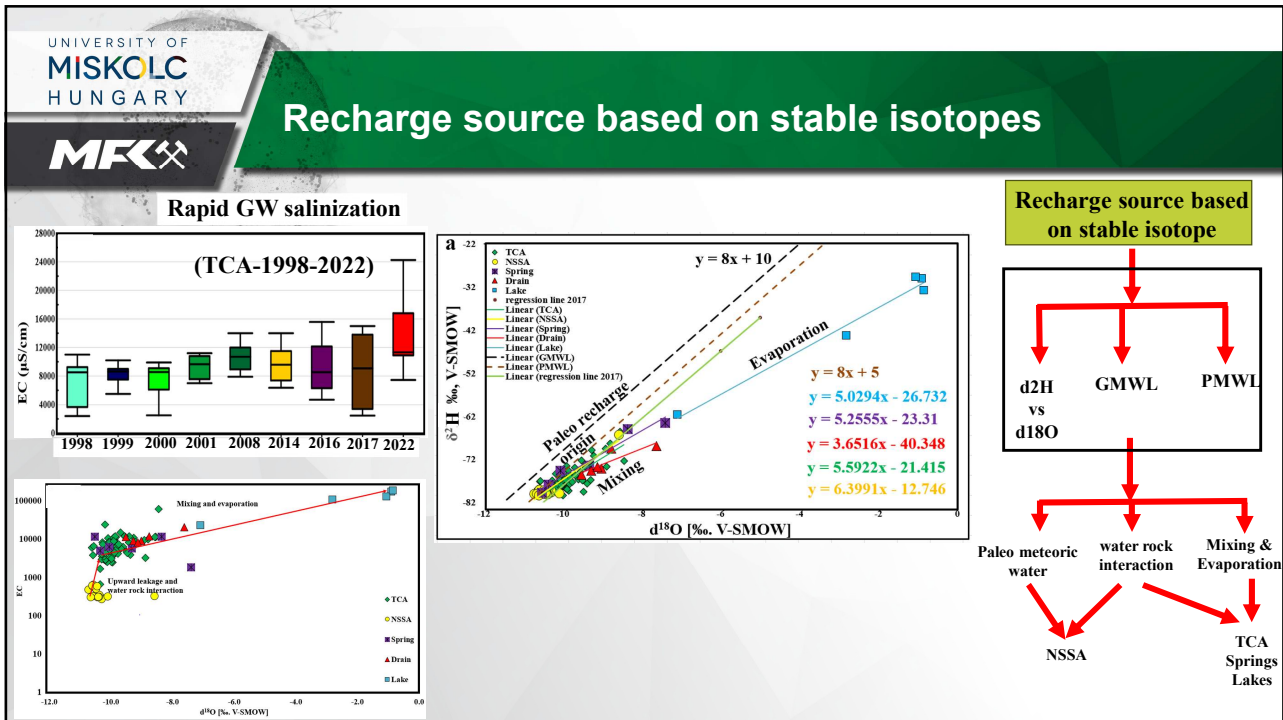
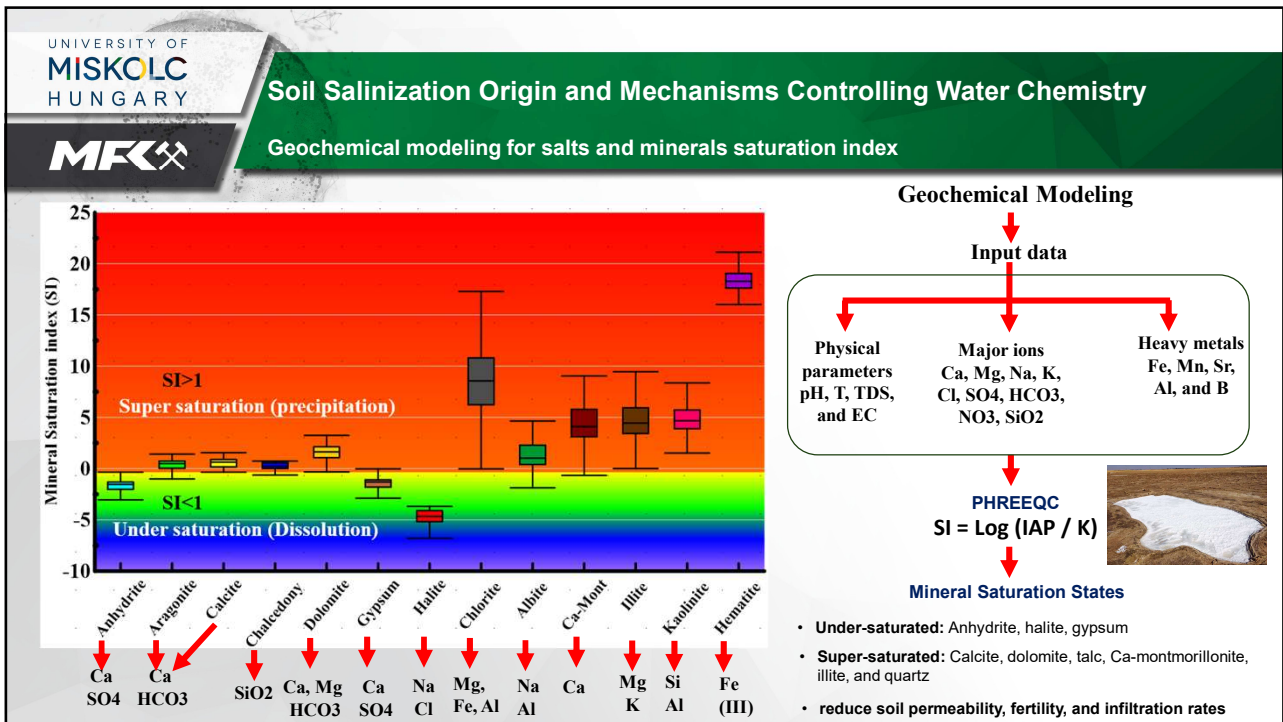

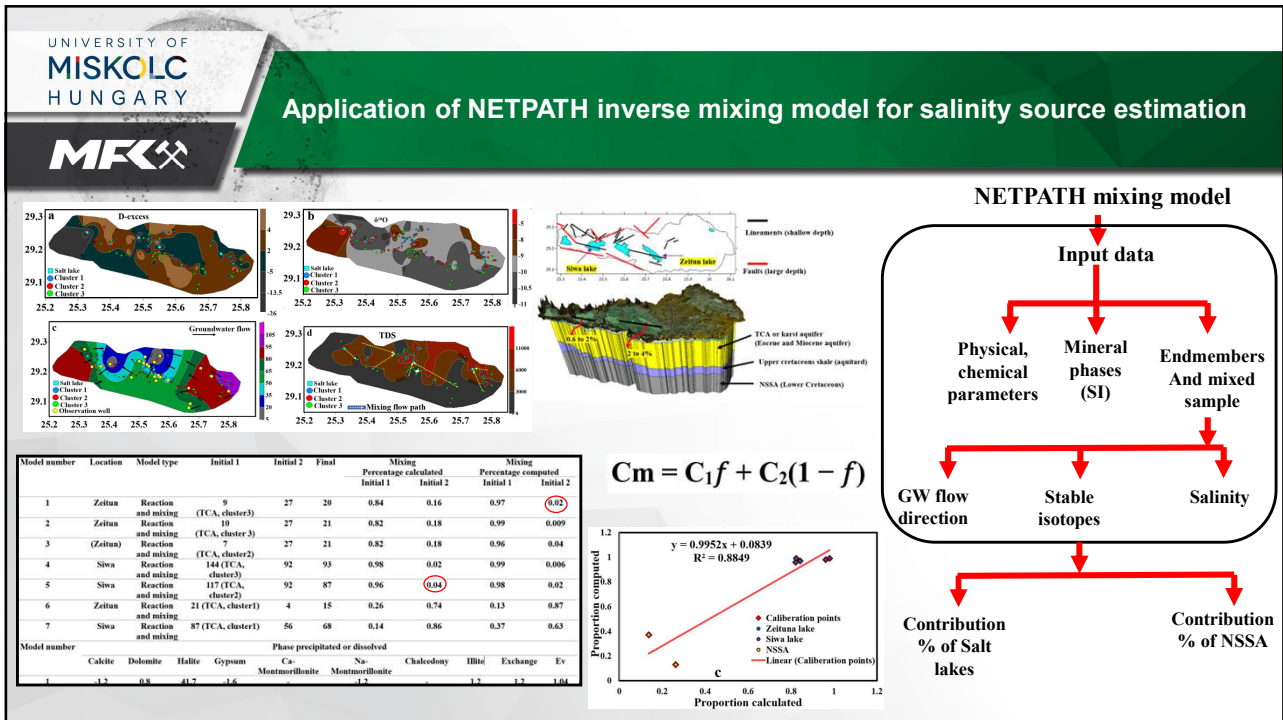
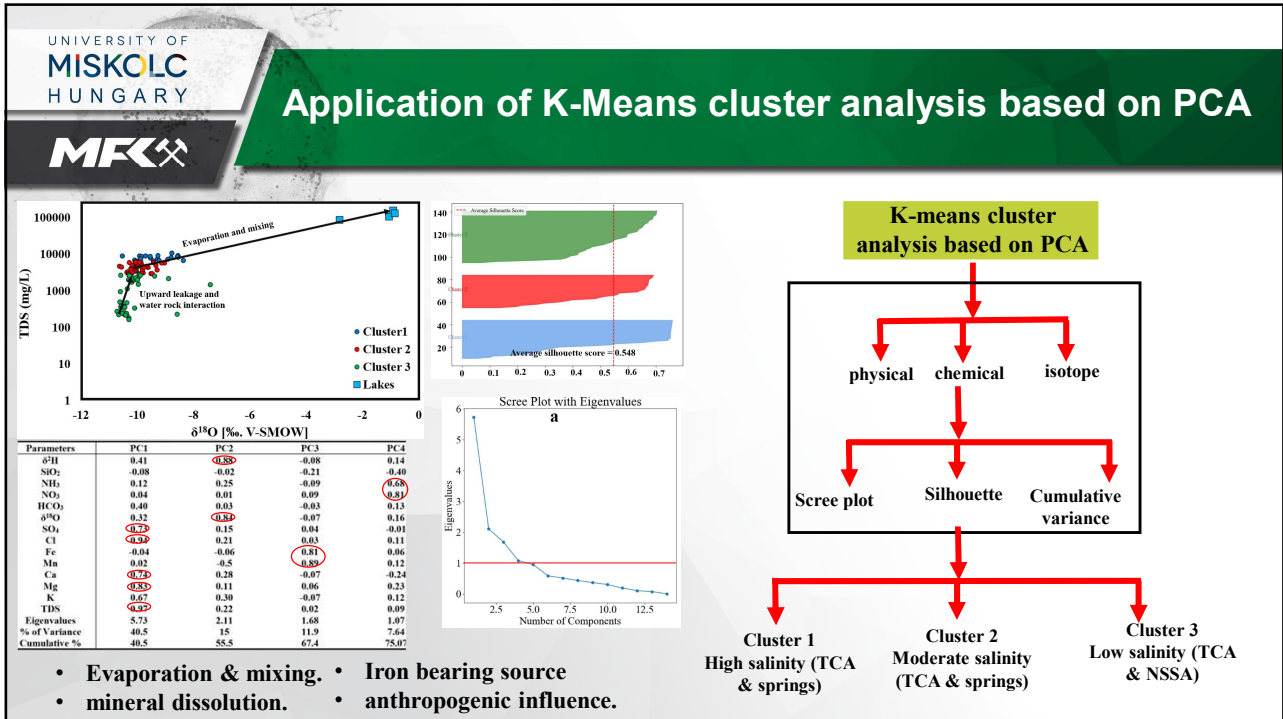

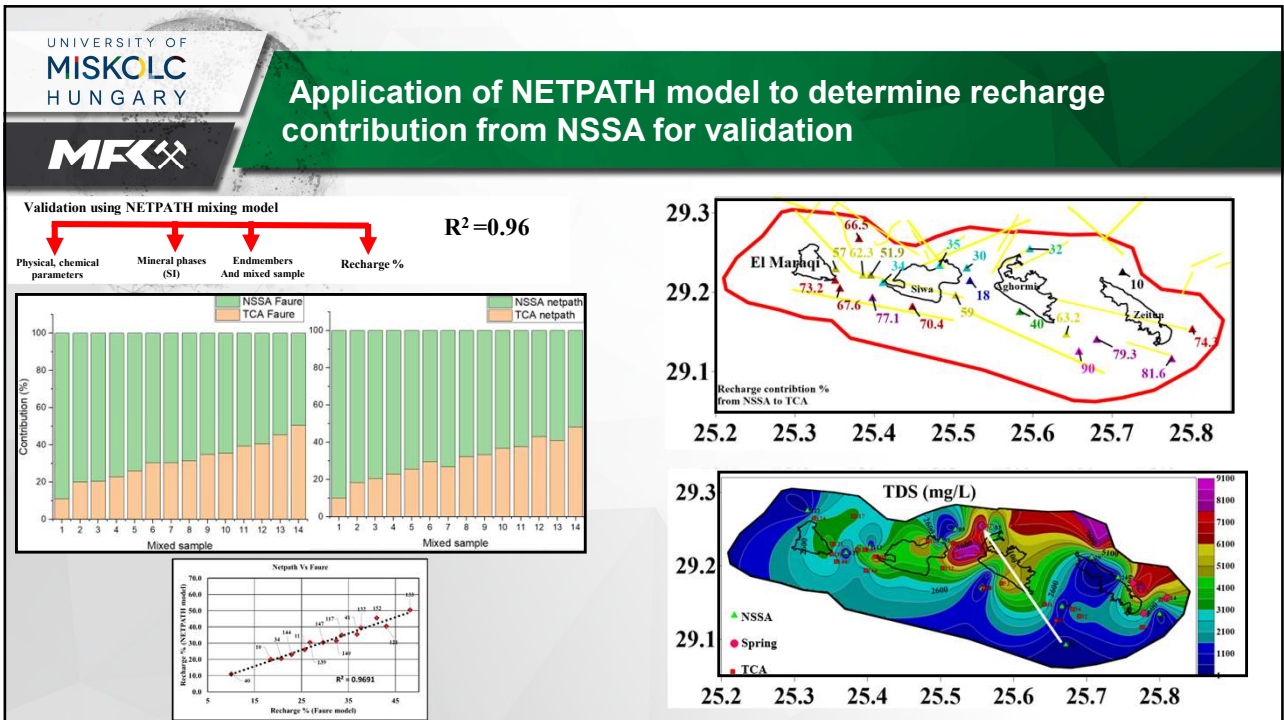
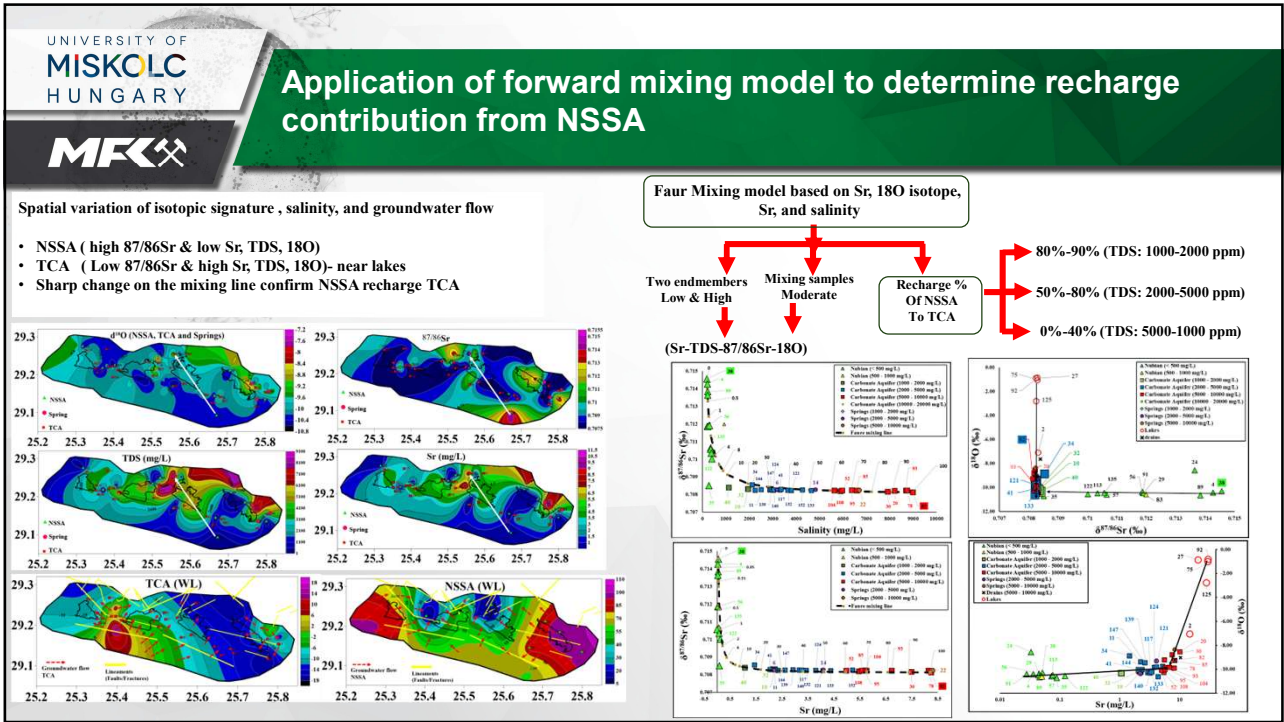

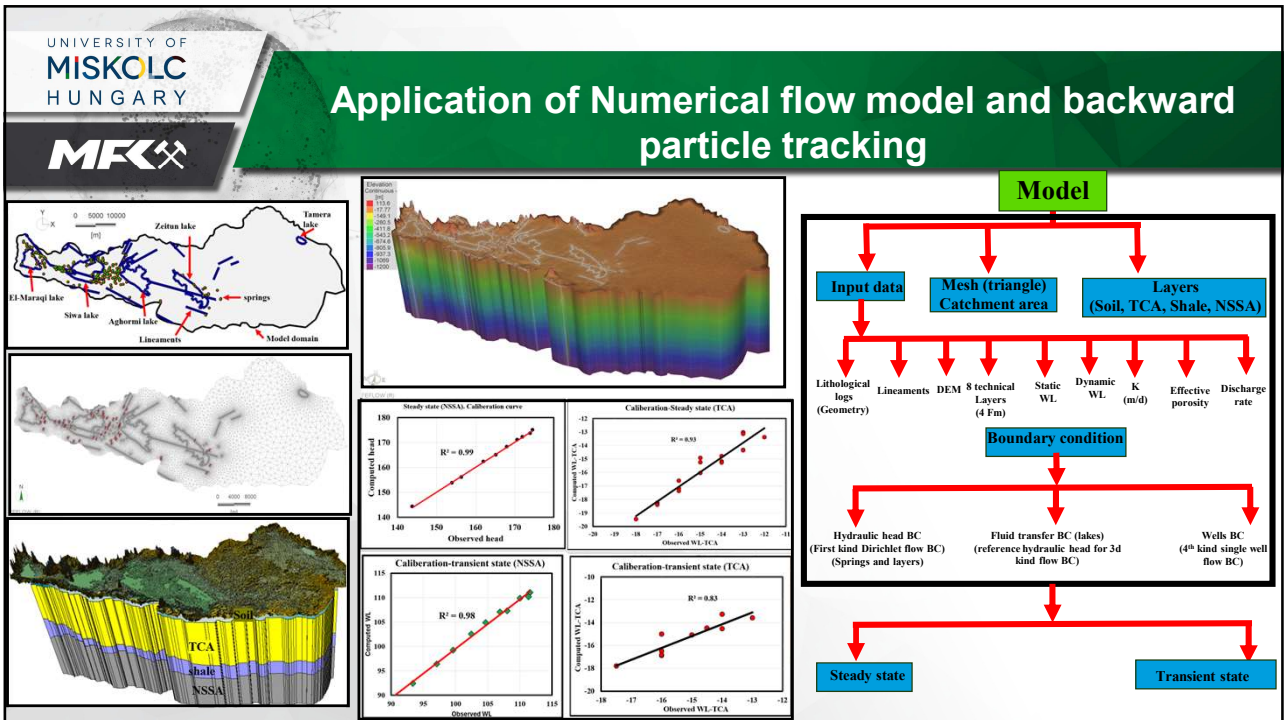
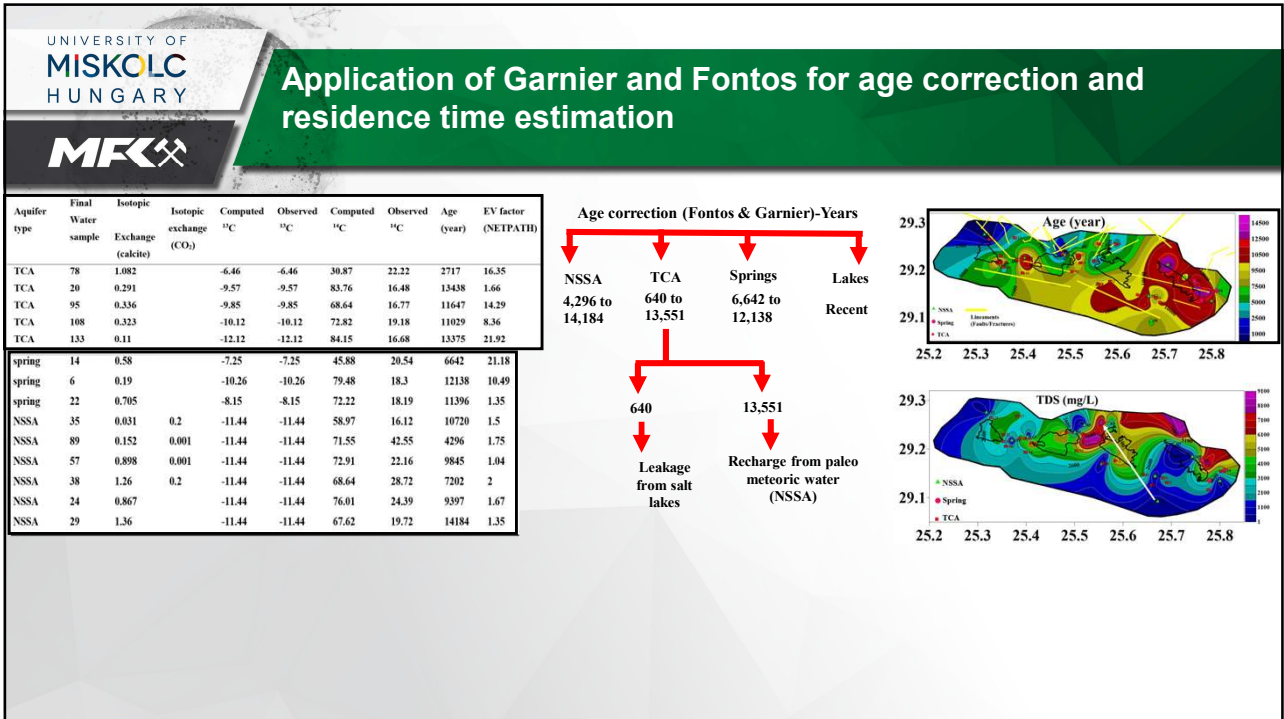

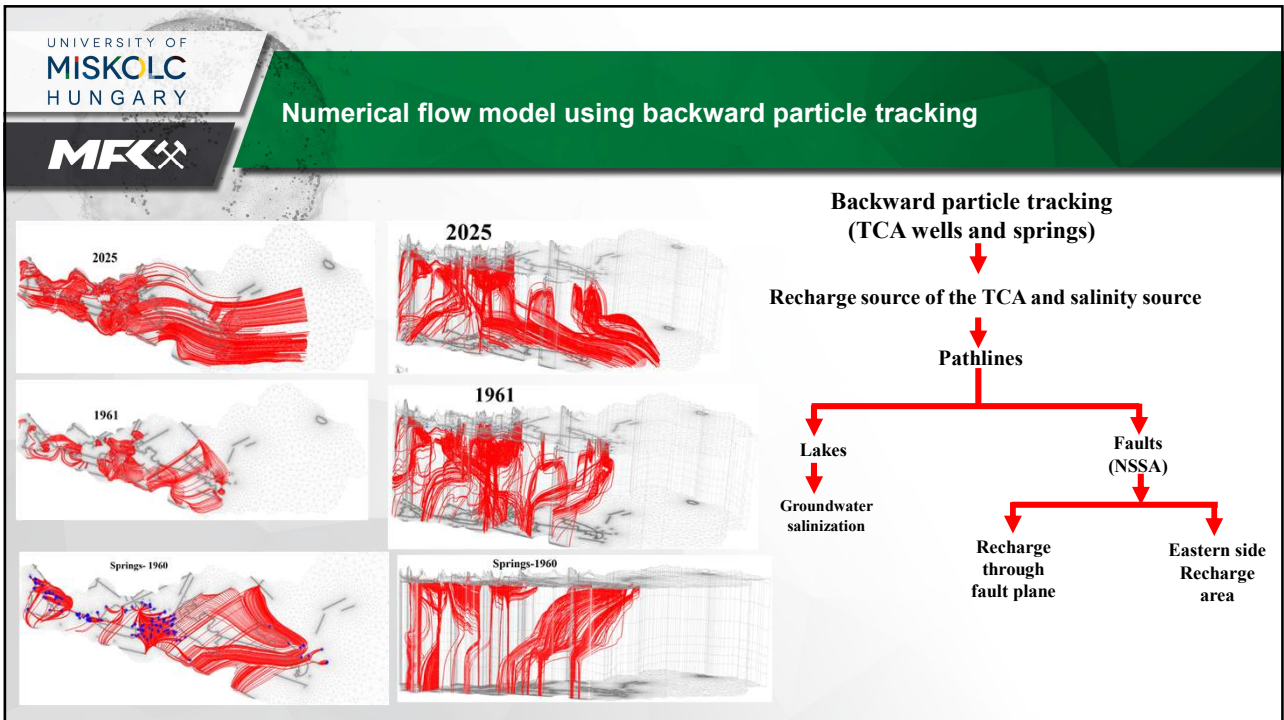
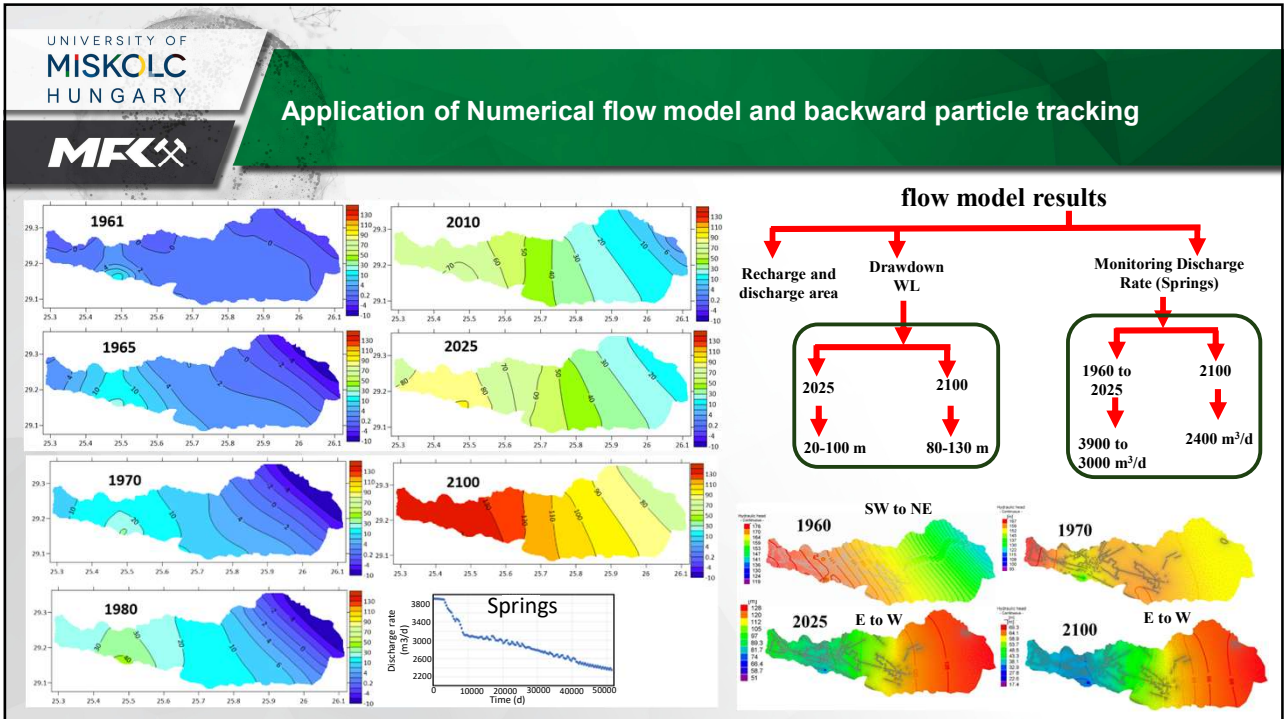

UNIVERSITY OF MISKOLC HUNGARY

**Practical applicability and water management implications**

MFK

1. Mixing of Freshwater and Brackish Water.
2. Water Treatment to Reduce Hardness and salinity and Prevent Soil Degradation.
3. Subsurface drip Irrigation Practices.
4. drilling canal should be constructed to link the four major salt lakes and transfer to artificial lake.
5. Implementing a drainage system consisting of cement-covered channels.
6. Perforated pipe system to remove water logged in the soil.

UNIVERSITY OF MISKOLC HUNGARY

**Conclusions**



MFK



1. Self-Organizing Maps (SOM) and k-means clustering successfully delineated three distinct lithological units within the Nubian Sandstone Aquifer System (NSSA) - sand layers, shaly sand, and shale - with SOM proving more accurate than k-means for estimating aquifer layer thickness and providing higher-resolution identification of thin layers. This method could be applied in case of lack of data from cutting samples.
2. Hydraulic conductivity validation using both Kozeny-Carman and Cooper-Jacob methods showed strong agreement ( $R^2 = 0.92$ ), with the highest values in central Siwa Oasis. The hydraulic conductivity ranged from 1.2 m/d to 6.6 m/d and effective porosity from 0.2 to 0.3 which could be used for groundwater flow modeling.
3. Remote sensing analysis and SVM could predict the rapid increase of hypersaline lakes from 22.6 km<sup>2</sup> in 1990 to 60.6 km<sup>2</sup> in 2020 causing soil salinization.
4. Geochemical modeling using PHREEQC identified mineral supersaturation conditions for montmorillonite (87% of samples), calcite, dolomite, and clay minerals that reduce soil permeability and increase waterlogging.
5. Stable isotope analysis revealed that both the NSSA and TCA contain paleo-meteoric water with  $\delta^{18}O$  values ranging from -10.71 to -8.57‰ for NSSA and -10.62 to -8.45‰ for TCA, while salt lakes showed highly enriched values (-7.09 to -0.85‰) due to intense evaporation.
6. NETPATH mixing model quantified that hypersaline lakes contribute 0.6-4% to TCA salinity through downward seepage, while NSSA provides 63-87% freshwater contribution through upward flow, with strong model calibration ( $R^2 = 88\%$ ) confirming that despite small percentages, the extremely high TDS of salt lakes (130,992-153,589 mg/L) significantly impacts groundwater quality.
7. The Faure mixing model successfully quantified NSSA contributions to TCA recharge, demonstrating 80-90% NSSA input in low-salinity areas (1000-2000 mg/L) along fault planes, 50-80% in intermediate zones (2000-5000 mg/L), and minimal contributions (0-40%) in high-salinity northern regions (5000-9000 mg/L) near salt lakes.
8. Groundwater age correction using radiocarbon dating revealed significant temporal variations with TCA ages ranging from 640-13,551 years and NSSA ages from 4,296-14,184 years, showing a clear spatial trend of decreasing age from southeast to north, with youngest ages near Siwa Lake indicating active mixing and recharge processes. The relationship between  $^{87}Sr/^{86}Sr$  ratios and groundwater age demonstrated that older groundwater (>10,000 years) concentrated near fault systems preserves paleowater from the African Humid Period, while younger northern waters reflect mixing with surface sources, confirming that structural features control both recharge pathways and preservation of ancient groundwater signatures.



## Conclusions



- Groundwater numerical flow modeling using FEFLOW demonstrated critical drawdown patterns from 1960-2025, showing dramatic water level decline from 175m to 75m above sea level in western areas and slower decline from 142m to 128m in eastern regions, with future predictions indicating water levels will drop to 30-70m by 2100 under current extraction rates of 330,000 m<sup>3</sup>/day.
- Spring discharge monitoring showed significant decline from 3,900 m<sup>3</sup>/d in 1960 to 3,000 m<sup>3</sup>/d in 2025, with projections indicating further reduction to 2,400 m<sup>3</sup>/d by 2100, directly correlating with decreasing pressure heads and threatening natural water resources for agriculture and tourism.
- Reverse particle tracking analysis provided definitive validation of NSSA-to-TCA recharge mechanisms, with all 24 particles released from each TCA tracing back to the NSSA along distinct fault and fracture pathways, confirming that structural features serve as primary conduits for upward groundwater flow between aquifer systems. The pathlines reaches the salt lakes confirming the leakage downward of salt lakes.
- The modeling results identified a critical threshold scenario where NSSA may cease recharging TCA within 150-200 years under current extraction rates, potentially reversing flow dynamics and causing saline TCA water to contaminate the freshwater NSSA, representing an existential threat to Siwa Oasis's water security and requiring immediate sustainable management interventions.



 	
<h2 style="text-align: right;">3D gravity inversion input parameters</h2> <p style="text-align: right;">1) Target depth : 0,5 Km</p>	
Category	Details
Software / Algorithm Used	Grav3D (Pham et al., 2021) – Iterative inversion using Fourier domain forward modeling (MATLAB GUI: GRV_3D_inv.m)
Input data	Residual Map_0,5Km
Target Depth	0–500 meters
Density Contrast ( $\Delta\rho$ )	0,22 g/cm <sup>3</sup> (carbonate lithology)
Mean Depth Assumed	500 m (based on well log data and literature)
Filtering Parameters	Shelf Height (SH) = 0.099 km <sup>-1</sup> Wavenumber Half-width (WH) = 0.08 km <sup>-1</sup>
Initial Condition ( $z_0$ )	500 m
Boundary Assumptions	Horizontal interface, constant average density, no lateral density variation
A Priori Information	Carbonate lithology and depth from Soliman (2016) and well logs
Validation Performed	Yes – compared to 14 well log profiles
Inversion Objective	Reconstruct geometry of shallow density variations and map near-surface structures
Hyperparameters	RMS misfit threshold = $1 \times 10^{-4}$ ; iteration stops when RMS falls below this value
Nonuniqueness Handling	Fixed density and depth constraints
Trial-and-Error Workflow	SH & WH filter parameters and RMS threshold were tuned iteratively; model refined until RMS stopped improving.
Iterations to Converge	25 iterations
Initial RMS	0,00534 Km

 	
<h2 style="text-align: right;">3D gravity inversion input parameters</h2> <p style="text-align: right;">2) Target depth : 3,5 Km</p>	
Category	Details
Software / Algorithm Used	Grav3D (Pham et al., 2021) – Iterative inversion using Fourier domain forward modeling (MATLAB GUI: GRV_3D_inv.m)
Input data	Residual Map_3,5Km
Target Depth	~3–3.5 km
Density Contrast ( $\Delta\rho$ )	2.6 g/cm <sup>3</sup> (sedimentary rocks) 2.7 g/cm <sup>3</sup> (basement)
Mean Depth Assumed	3–3.5 km (based on borehole and geological data)
Filtering Parameters	Shelf Height (SH) = 0.099 km <sup>-1</sup> Wavenumber Half-width (WH) = 0.086 km <sup>-1</sup>
Initial Condition ( $z_0$ )	~3 km
Boundary Assumptions	Horizontal interface, constant average density per geological unit
A Priori Information	Borehole logs, Soliman (2016), and known basement depth profiles
Validation Performed	Yes – compared inversion output with 14 well log datasets
Inversion Objective	Map deeper geological units and basement geometry
Hyperparameters	RMS misfit threshold = $1 \times 10^{-4}$
Nonuniqueness Handling	Density and depth constraints from prior studies and log data
Trial-and-Error Workflow	SH & WH values adjusted in successive runs; model accepted once RMS reduction plateaued.
Iterations to Converge	55 iterations
Initial RMS	0.01422 km
Final RMS Misfit	$9.09 \times 10^{-5}$ km

  <h2 style="margin: 0;">3D gravity inversion input parameters</h2>	
Category	Details
Software / Algorithm Used	Grav3D (Pham et al., 2021) – Iterative inversion algorithm based on Fourier domain forward modeling implemented in MATLAB (GUI: GRV_3D_inv.m)
Method Objective	Reconstruct 3D geometry of horizontal density interfaces from residual gravity data at 1 km and 7 km upward continuations
Targeted Depths	- Shallow model: 0–0.5 km- Deep model: up to ~3.5 km
Model Inputs	- Residual gravity anomalies- Density contrast ( $\Delta\rho$ )- Mean depth of interface- Roll-off filter parameters (SH & WH)- RMS threshold
Input Parameters for Shallow	- $\Delta\rho = 2.2 \text{ g/cm}^3$ (carbonate)- Mean depth = 500 m- SH = $0.099 \text{ km}^{-1}$ - WH = $0.08 \text{ km}^{-1}$
Input Parameters for Deep	- $\Delta\rho = 2.6\text{--}2.7 \text{ g/cm}^3$ (sedimentary and basement)- Mean depth = 3–3.5 km- SH = $0.099 \text{ km}^{-1}$ - WH = $0.086 \text{ km}^{-1}$
Hyperparameters	- RMS misfit threshold = $1 \times 10^{-4}$ - Filtering parameters (SH, WH)- Iteration stops when RMS < threshold
Initial Conditions	- Initial depth assumed at $z_0 = 500 \text{ m}$ - Topography of interface estimated via Fourier transform
Boundary Condition Assumptions	- Horizontal density interface- Constant average density per unit- No lateral variation in fixed density zones
Nonuniqueness Issue	Addressed using a priori constraints (density and depth from literature and well logs)
A Priori Information Used	- Lithology and depth from well logs and Soliman (2016); 14 well logs used to define constraints and validate results
Validation Performed	Yes – final inversion results and estimated depths validated against 14 well logs across the study area
Errors	No formal sensitivity analysis or error quantification presented

## Gravity 3D Inversion Mathematical background

This study utilizes FFT-based inversion, integrating Oldenburg's (1974) method with Xu's (2006) approach, to iteratively estimate the geometry of perturbing bodies from gravity anomalies, ensuring precise reconstruction of density interfaces:

$$h(x, y) = F^{(-1)} \left[ -\frac{F[\Delta g(x, y)] e^{k|z_0}}{2\pi G \rho} - \sum_{n=2}^{\infty} \frac{|k|^{n-1}}{n!} F[h^n(x, y)] \right]$$

where:

- $h$  is the interface topography at coordinates  $(x, y)$ ,
- $F$  and  $F^{(-1)}$  denote the Fourier transform and its inverse, respectively,
- $\Delta g$  is the gravity field,
- $k$  is the radial wavenumber, defined as  $\sqrt{k_x^2 + k_y^2}$ , where  $k_x$  and  $k_y$  are the wavenumbers in the  $x$  and  $y$  directions,
- $z_0$  is the average depth to the density interface,
- $G$  is the gravitational constant,
- $\rho$  is the density contrast.

The iterative process begins by computing the Fourier transform of the first part of Equation (1), assuming  $z_0 = 0.5 \text{ km}$ , to obtain an initial approximation of the interface topography  $h$ . Subsequent depth estimates are calculated using the  $h$  values from the previous step. The process continues until convergence is achieved, measured by the root mean square error (RMS) between successive depth estimates:

$$RMS = \sqrt{\frac{\sum_{j=1}^M \sum_{j=1}^N (h_{ij}^{t+1} - h_{ij}^t)^2}{M \cdot N}}$$

where:

- $M$  and  $N$  are the grid sizes in the north and east directions, respectively,
- $t$  represents the iteration step.

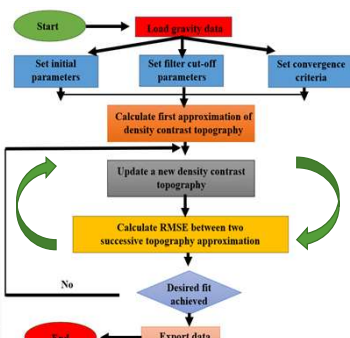

UNIVERSITY OF  
**MISKOLC**  
HUNGARY



## Gravity data origin

Airborne gravity data were acquired by Getech Group using a LaCoste & Romberg air-sea gravimeter system. Flight specifications included: survey altitude of 600 m above ground level, flight line spacing of 2 km with 10 km tie lines, GPS navigation with differential correction, and data sampling at 1-second intervals. Bouguer anomaly calculations used a reduction density of 2.67 g/cm<sup>3</sup> and included terrain corrections using a 90-m digital elevation model.

Correction	Equation	Purpose
<b>1. Free-Air Correction (FAC)</b>	$\Delta g_{FAC} = 0.3086 \times H$ (mGal)	Adjusts for gravity variation due to elevation; brings measured gravity to sea level assuming no mass between point and geoid
<b>2. Latitude Correction</b>	$\gamma(\phi) = 978032.7 (1 + 0.0053024 \sin^2 \phi - 0.0000059 \sin^2 2\phi)$ (mGal)	Corrects for Earth's shape and rotation (gravity is higher at the poles than at the equator)
<b>3. Bouguer Slab Correction</b>	$\Delta g_B = 0.04193 \times \rho \times H$ (mGal)	Removes the gravitational effect of the rock slab between the measurement point and sea level
<b>4. Terrain Correction</b>	Computed numerically (e.g., Hammer or prism method)	Accounts for topographic irregularities (e.g., hills and valleys) that affect the gravity reading
<b>Final Bouguer Anomaly</b>	$g_{Bouguer} = g_{obs} + \Delta g_{FAC} - \gamma(\phi) - \Delta g_B + \Delta g_{terrain}$ (mGal)	Provides corrected gravity value that reflects subsurface density variations

UNIVERSITY OF  
**MISKOLC**  
HUNGARY



## Magnetic data origin

### Magnetic Data Corrections Toward Reduction to the Pole (RTP)

Step	Correction / Transformation	Purpose	Mathematical / Conceptual Basis
<b>1. Diurnal Correction</b>	Subtract magnetic base station readings	Remove short-term variations in Earth's magnetic field	$T_{corr} = T_{obs} - T_{base}(t)$
<b>2. IGRF Correction</b>	Remove Earth's main magnetic field (International Geomagnetic Reference Field - IGRF)	Isolate crustal magnetic sources	$T_{res} = T_{corr} - T_{IGRF}$
<b>3. Leveling / Micro-leveling</b>	Adjust for aircraft or sensor drift, tie-line mismatches	Remove instrument and flight inconsistencies	Polynomial or grid-based leveling algorithms
<b>4. Regional-Residual Separation</b>	Remove regional trends using upward continuation or polynomial fitting	Focus on local anomalies	$T_{residual} = T_{data} - T_{regional}$
<b>**5. Reduction to the Pole (RTP)</b>	Convert skewed anomaly (due to inclination/declination) to symmetric anomaly over the source	Center the magnetic anomaly directly over the source	Applies a frequency-domain filter: $RTP(k_x, k_y) = \frac{F(k_x, k_y)}{D(k) \cdot I(k)}$ using inclination & declination angles



UNIVERSITY OF  
**MISKOLC**  
HUNGARY

Applied filters

Filter	Description & Purpose	Mathematical Expression	Lineament Placement	Reason for Placement
<b>Total Horizontal Derivative (THD)</b>	Highlights lateral (horizontal) contrasts in the potential field. Good for outlining fault zones.	$THG = \sqrt{\left(\frac{\partial P}{\partial x}\right)^2 + \left(\frac{\partial P}{\partial y}\right)^2}$	Along <b>THD ridges (maxima)</b>	Ridges correspond to maximum horizontal gradient—likely structural edges/faults.
<b>Second Vertical Derivative (SVD)</b>	Enhances high-frequency signals; sharpens edges of shallow features.	$\frac{\partial^2 P}{\partial z^2}$	At <b>zero-crossings</b>	Zero-crossings mark inflection points—indicate abrupt density/magnetic contrast.
<b>Analytical Signal (AS)</b>	Combines vertical and horizontal gradients; produces always-positive values that highlight edges.	$AS = \sqrt{\left(\frac{\partial P}{\partial x}\right)^2 + \left(\frac{\partial P}{\partial y}\right)^2 + \left(\frac{\partial P}{\partial z}\right)^2}$	Along <b>AS maxima</b>	Peaks in AS occur directly over causative bodies—ideal for direct structural mapping.
<b>First Vertical Derivative (FVD)</b>	Enhances shallow structures by amplifying high-frequency components.	$\frac{\partial P}{\partial z}$	At <b>zero-crossings</b>	Highlights top boundaries of shallow sources—useful in aquifer studies.
<b>Tilt angle of the horizontal gradient</b>	Highlights structural edges by tilting horizontal derivatives.	$TAHG = \tan^{-1} \left( \frac{\frac{\partial HP}{\partial z}}{\sqrt{\left(\frac{\partial HP}{\partial x}\right)^2 + \left(\frac{\partial HP}{\partial y}\right)^2}} \right)$	Along <b>TAHG maxima</b>	Accentuates directional trends and edge orientations
<b>Tilt Angle (TA)</b>	Normalizes vertical derivative by the horizontal; stable over noise and depth variations.	$TA = \tan^{-1} \left[ \frac{\frac{\partial P}{\partial z}}{\left(\frac{\partial P}{\partial x}\right)^2 + \left(\frac{\partial P}{\partial y}\right)^2} \right]$	Along <b>zero-contours (TA = 0)</b>	TA = 0 typically traces source boundaries and faults—especially robust in noisy areas.

P is the amount of the gridded gravity or magnetic anomaly reduced to the pole



UNIVERSITY OF  
**MISKOLC**  
HUNGARY

Gravity - For more info

Map Type	What It Shows	Depth Range	Main Anomalies Represented
<b>Bouguer Gravity Anomaly</b>	Combined effect of all subsurface density variations	From surface to several km deep	All anomalies (shallow + deep), mixed signals
<b>Upward Continuation to 1 km</b>	Suppresses shallow signals; highlights deeper structures	Sources at and below ~500 m	Smoothed anomalies, regional trends, deep-rooted density contrasts
<b>Upward Continuation to 7 km</b>	Suppresses most shallow and intermediate signals; enhances very deep features	Sources at and below ~3.5 km	Long-wavelength anomalies, deep tectonic structures
<b>Residual from 1 km (0.5 km depth)</b>	Isolates shallow sources by removing deeper contributions	Shallower than ~500 m	Local faults, fractures, lithological boundaries in aquifer zone
<b>Residual from 7 km (3.5 km depth)</b>	Highlights intermediate-shallow structures; filters out deep contributions	Shallower than ~3.5 km	Fault zones, sedimentary layering, aquifer-related lineaments

UNIVERSITY OF  
**MISKOLC**  
HUNGARY



## Magnetic - For more info

Map Type	What It Shows	Depth Range	Main Anomalies Represented
<b>Total Magnetic Intensity (TMI)</b>	Combined magnetic effect of all subsurface sources, influenced by Earth's field	From surface to several km	Mixed-depth anomalies, skewed due to field inclination/declination
<b>Reduction to the Pole (RTP)</b>	Centers magnetic anomalies over causative bodies by removing field geometry effects	All depths	Corrected anomalies aligned vertically, improved structural location accuracy
<b>Upward Continuation to 1 km</b>	Remove shallow magnetic signals; emphasizes deeper structures	Sources at and below ~500 m	Broad, smoothed anomalies from deeper magnetic bodies
<b>Upward Continuation to 7 km</b>	Filters out shallow/intermediate signals; highlights very deep features	Sources at and below ~3.5 km	Large-scale tectonic features, deep magnetic basement structures
<b>Residual from 1 km (0.5 km)</b>	Highlights shallow sources by removing deeper regional contributions	Shallower than ~500 m	Faults, dikes, lithological contacts in upper crust
<b>Residual from 7 km (3.5 km)</b>	Enhances intermediate-to-shallow sources by filtering deeper trends	Shallower than ~3.5 km	Basement topography, sedimentary layering, shallow structural features



**MISKOLCI**  
EGYETEM  
UNIVERSITY OF MISKOLC



The Energy Water Food Climate Nexus Summit  
26-28 August 2025

## **Cement Kiln Dust use in Environmental Remediation: A Review of Applications**

Presented by: Sirine Trabelsi, PhD student  
Mikoviny Sámuel Doctoral School of Earth Sciences,  
University of Miskolc  
Supervisors: Dr. Andrea Tóth, Associate professor  
Dr. Tamás Kántor, Associate professor

### **Overview**

- Introduction
- Importance of the topic
- Environmental Applications of CKD
- Benefits and Limitations
- Conclusion





# Introduction

Environmental threats are intensifying at an alarming rate, with greenhouse gas emissions, climate change, water pollution, and increasing waste generation posing severe risks to ecosystems and human well-being (Achuo et al., 2023). Achieving a sustainable future has become a global imperative, demanding urgent action across all sectors.



## WHAT IS CKD?

Cement Kiln Dust (CKD) is an ultrafine, highly alkaline byproduct of cement production, collected from kiln exhaust gases by pollution control systems.

**Physical Properties:**  
Fine powder, high surface area, cementitious behavior.

**Chemical Properties:**  
Contains calcium oxide (CaO), silica (SiO<sub>2</sub>), and alumina (Al<sub>2</sub>O<sub>3</sub>).



## Processing Flowchart of CKD

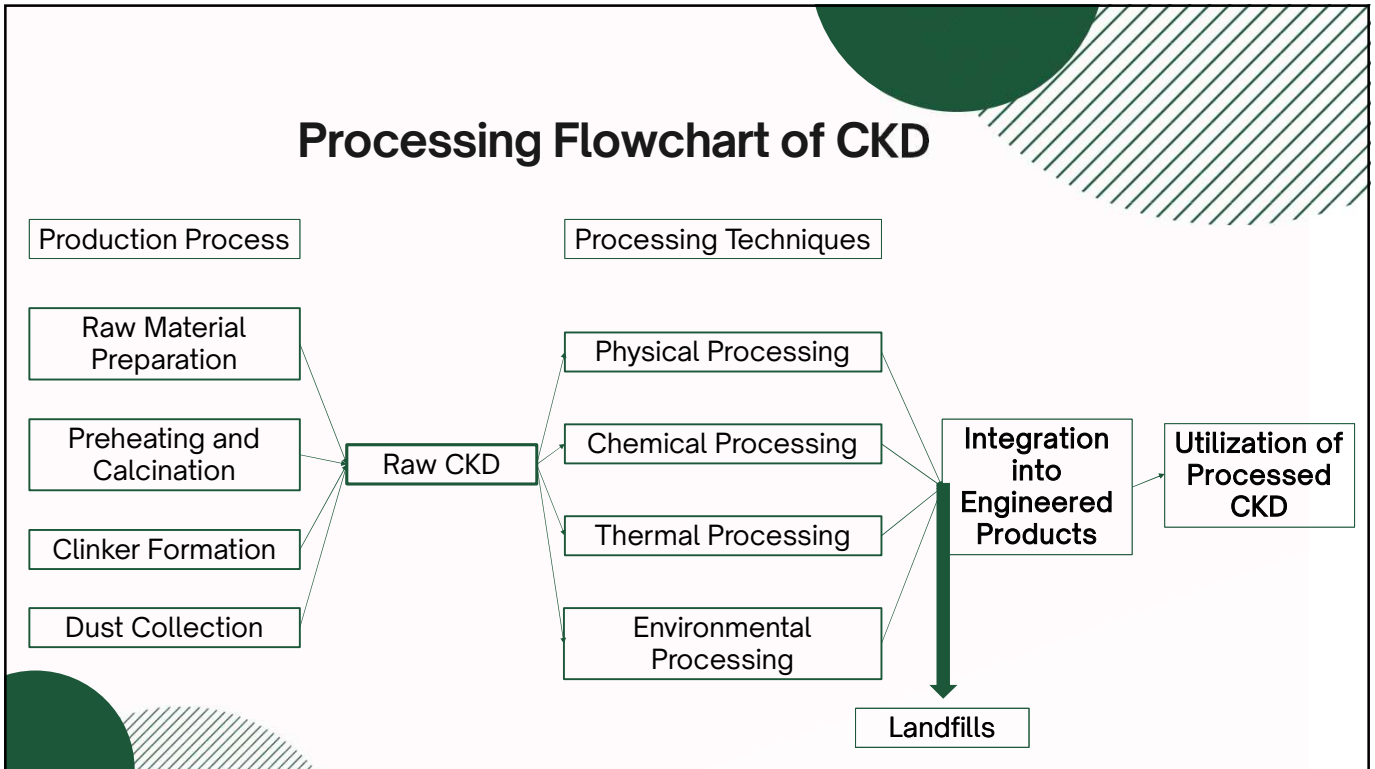

## Importance of the topic

1

### Decreasing the Carbon Footprint

The cement industry is a major contributor to global CO<sub>2</sub> emissions, accounting for approximately 7-8% of the world's total anthropogenic CO<sub>2</sub>.

2

### The Circular Economy and Waste Management

CKD an abundant by-product of the cement production process, has increased in parallel with the speeding growth of cement manufacturing and has resulted in its accumulation.

3

### Innovation and Research

The reuse of CKD has drawn the interest of many researchers and engineers to explore its reuse.

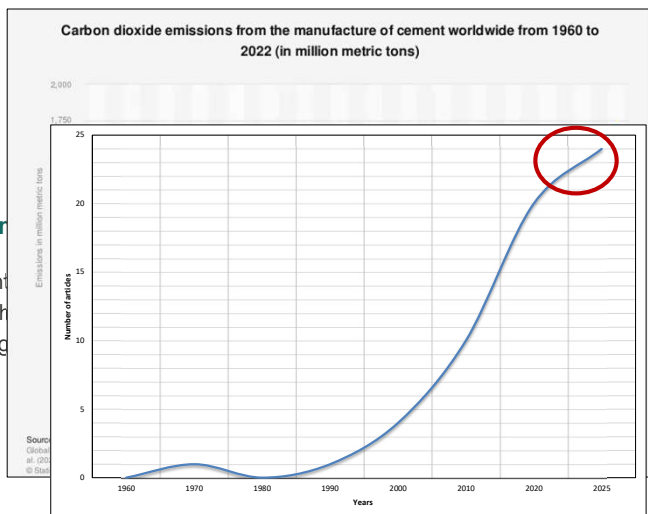

Growth of scientific articles tackling the use of CKD over time (1960-2025)

## Environmental Application of CKD

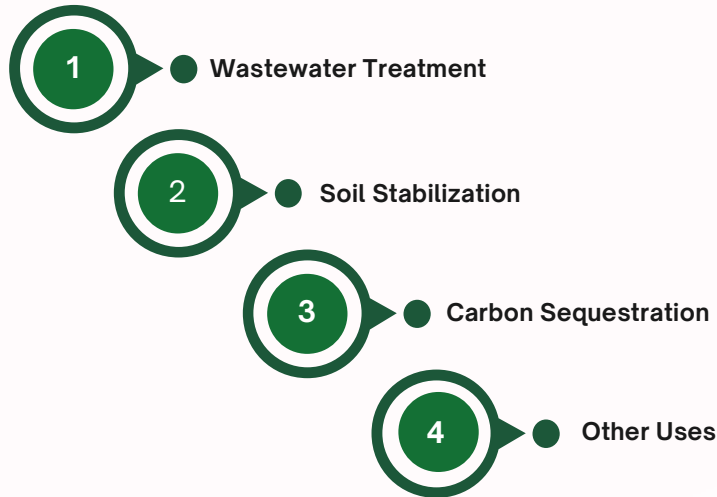

## Wastewater Treatment

### Heavy Metal Removal

Effective in removing heavy metals and organic pollutants.

98% for Pb, 94% for Zn, 92% for Cu, and 90% for Cd within just 4h of treatment (Elmaadawy, 2024).

### Acid Neutralization

CKD is used in acidic industrial wastewater to raise its pH to a safe level before it's released into the environment.

CKD removes contaminants through two main mechanisms

#### Chemical Precipitation:

- CKD's high pH causes dissolved heavy metal ions to become insoluble.
- They form solid precipitates that can be easily filtered out.

#### Adsorption

- The fine, porous nature of CKD provides a large surface area with many active sites.
- Metal ions bind to the CKD particles through various interactions, including Ion Exchange, surface complexation, and physical adsorption.

## Soil Stabilization

Improves properties of expansive and silty soils.

Reduces swell potential and increases compressive strength.

Used with additives (e.g., fly ash) for subgrade improvement.

Reduces construction costs and enhances pavement performance.

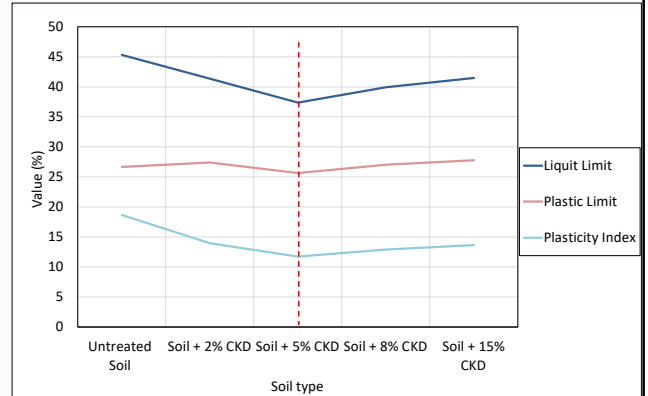

Effect of Cement Kiln Dust (CKD) addition on Atterberg Limits of soil mixes  
high-plasticity soil → medium-plasticity soil

## Carbon Sequestration

Carbon sequestration is the long-term process of capturing and storing carbon dioxide (CO<sub>2</sub>) from the atmosphere to prevent it from contributing to climate change.

Cement kiln dust (CKD) can be used for carbon sequestration through a process called **mineral carbonation**.

This is a chemical reaction where the alkaline components of the CKD react with carbon dioxide (CO<sub>2</sub>) to form stable carbonate minerals.

When CKD is exposed to CO<sub>2</sub> in the presence of water, the following reaction occurs:

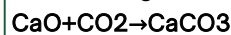

- Calcium oxide (CaO) from the CKD.
- Carbon dioxide (CO<sub>2</sub>) from the atmosphere or a captured source.
- Calcium carbonate (CaCO<sub>3</sub>), a stable, solid mineral (the same compound as limestone), is formed.

Under optimized conditions, studies show that it can achieve a high Carbonation Degree (CD), often exceeding **60%** of its theoretical maximum (Huntzinger et al., 2009).

## Other Uses

### Agricultural and soil amendment

Used as a liming material to correct acidic soils (depending on composition)

### Mine Backfill and Stabilization

Potential for use as a partial cement replacement in mine backfill.

### Manufacturing & Industrial Uses

- Raw material for glass, ceramics, and geopolymer production.
- As a mineralizing agent in wood preservation.

## Benefits

Diverts waste from landfills

Reduces raw material consumption

Lowers carbon footprint

Offers cost savings in remediation and construction

## Limitations

Variability in CKD composition can affect performance

Leachate may contain hazardous compounds

Requires careful management and treatment before use

Research Gaps

## Conclusion

- Cement kiln dust (CKD) is a valuable by-product with strong potential in **environmental remediation**.
- Demonstrated effectiveness in **wastewater treatment, soil stabilization, and CO<sub>2</sub> sequestration**.
- Additional applications in construction, mining, and waste management expand its usefulness.

To realize its full potential, CKD requires standardized utilization guidelines, exploration of new applications such as agriculture and advanced materials, expansion of pilot-scale trials, and integration into the circular economy.



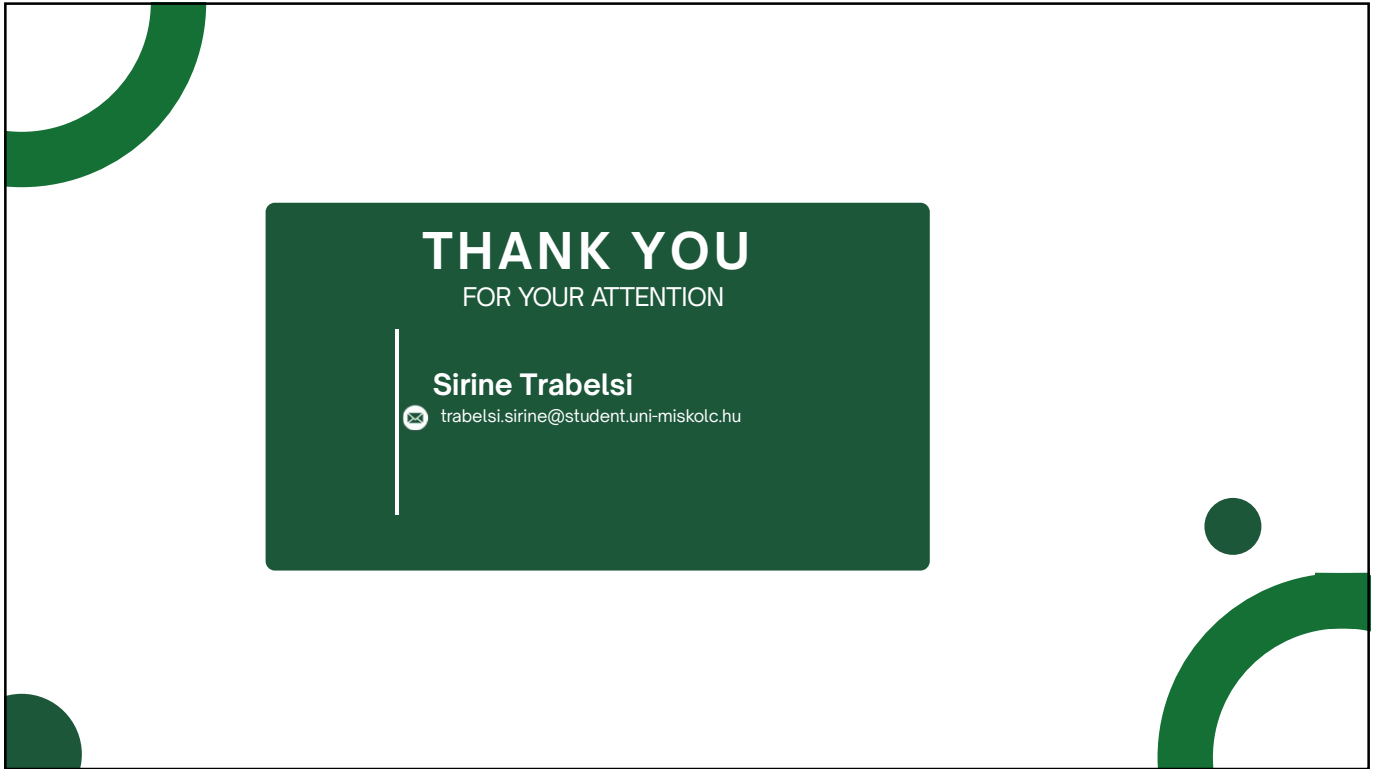



## Immobilization of TiO<sub>2</sub>/CNT composites in the material and surface of membranes used for the treatment of oily wastewater

**Tímea Miklós**  
Environmental Engineering MSc

Supervisor:  
**Dr. Gábor Veréb**



2025.08.27.

EnergyWaterFoodClimateNexus

### INTRODUCTION

#### Oily wastewaters

Industrial process	Oil concentration (mg/L)	Emission limit: 3-10 mg/L
Petroleum refining	20-4000	
Cooking oil refining	4000-6000	
Metal processing	100-20000	
Aluminum sheet production	5000-50000	
Food processing	500-14000	
Ship cleaning	30-2000	
Car wash	50-2000	
Leather processing	200-40000	
Paint production	1000-2000	



**Floating and dispersed oil**  
*Traditional treatment methods*  
(skimming, chemical destabilisation, flotation, biological treatment)

**Emulsified oil?**



**Hydrocarbons:** benzene, toluene, xylene, polycyclic and volatile aromatic compounds

UNIVERSITAS SCIENTIARUM SZEGEDIENSIS  
UNIVERSITY OF SZEGED

2025.08.27.

EnergyWaterFoodClimateNexus

1/17

UNIVERSITAS SCIENTIARUM SZEGEDIENSIS  
UNIVERSITY OF SZEGED

## INTRODUCTION

### Membrane separation

PVDF membrane    Modification with hydrophilic nanoparticles

### Photocatalytic nanoparticles modified membranes:

- ✓ Excellent cleaning efficiency (>99%)
- ✓ Photocatalytic regenerability
- ✓ Chemical-free process

**TiO<sub>2</sub>**

Li et al., 2003  
Gao et al., 2009  
Leong et al., 2014  
Kovács et al., 2018

**TiO<sub>2</sub>/CNT (2%)**

Veréb et al., 2019  
Fekete et al., 2023

**TiO<sub>2</sub>/CNT-COOH**

Fazekas et al., 2023

Zeta potential:  
Membrane: -40 mV  
Oil droplets: -43 mV

Hydrophobic surface  
↓  
Fouling

Photocatalytic layer  
Hydrophilic nature  
↓  
Increased flux and flux recovery

2025.08.27.

EnergyWaterFoodClimateNexus

2/17

UNIVERSITAS SCIENTIARUM SZEGEDIENSIS  
UNIVERSITY OF SZEGED

## OBJECTIVES

- 1) More durable immobilization of nanoparticles with *blending* and *grafting*;
- 2) Applying TiO<sub>2</sub>/CNT-COOH<sub>2%</sub> composite for membrane modification;
- 3) Filtration of different oil emulsions – model and industrial wastewaters;
- 4) Photocatalytic regeneration of membranes;
- 5) Effect of pH value on membrane filtration

2025.08.27.

EnergyWaterFoodClimateNexus

3/17

## Investigated oil emulsions

**Oil-in-water emulsion (model wastewater):**  $d \sim 70\text{-}1200\text{ nm}$

- a) 380 mg crude oil + 37.62 g ultrapure water (100× dilution)
  - b) Intensive stirring (35000 rpm) → **Dispersion (1 wt%)**
  - c) After further dilution 10 min ultrasonic homogenization → **~100 ppm oil-in-water emulsion**
- Preparing 3 kind of model emulsions („A”, „B” and „C”)



**Industrial wastewater:**

- ~100 ppm
- Oilfield produced water
- South Hungarian region



2025.08.27.

EnergyWaterFoodClimateNexus

4/17

## Membrane filtration

**Millipore (XFUF07601) reactor**

- 250 mL emulsion → 200 mL permeate (VRR=5)  
(VRR=Volume Reduction Ratio)
- **0.1 MPa** transmembrane pressure; 350 rpm stirring

**Purification efficiency:**  
turbidity measurement (NTU)

$$\eta = \left(1 - \frac{Z_p}{Z_0}\right) \cdot 100\%$$



**Calculation of filtration parameters:**

Fluxes:  $J = \frac{dV}{A_m \cdot dt} [L/m^2h]$

Resistances:  $R_{total} = R_{membrane} + R_{reversible} + R_{irreversible} [1/m]$

$$R_{membrane} = \frac{\Delta p}{J_w \cdot \eta_w} [1/m]$$

$$R_{irreversible} = \frac{\Delta p}{J_{wA} \cdot \eta_w} - R_{membrane} [1/m]$$

$$R_{reversible} = \frac{\Delta p}{J_{inf} \cdot \eta_f} - R_{irreversible} - R_{membrane} [1/m]$$

Flux recovery ratio:  $FRR = \frac{J_{used}}{J_{initial}} \cdot 100\%$



2025.08.27.

EnergyWaterFoodClimateNexus

5/17

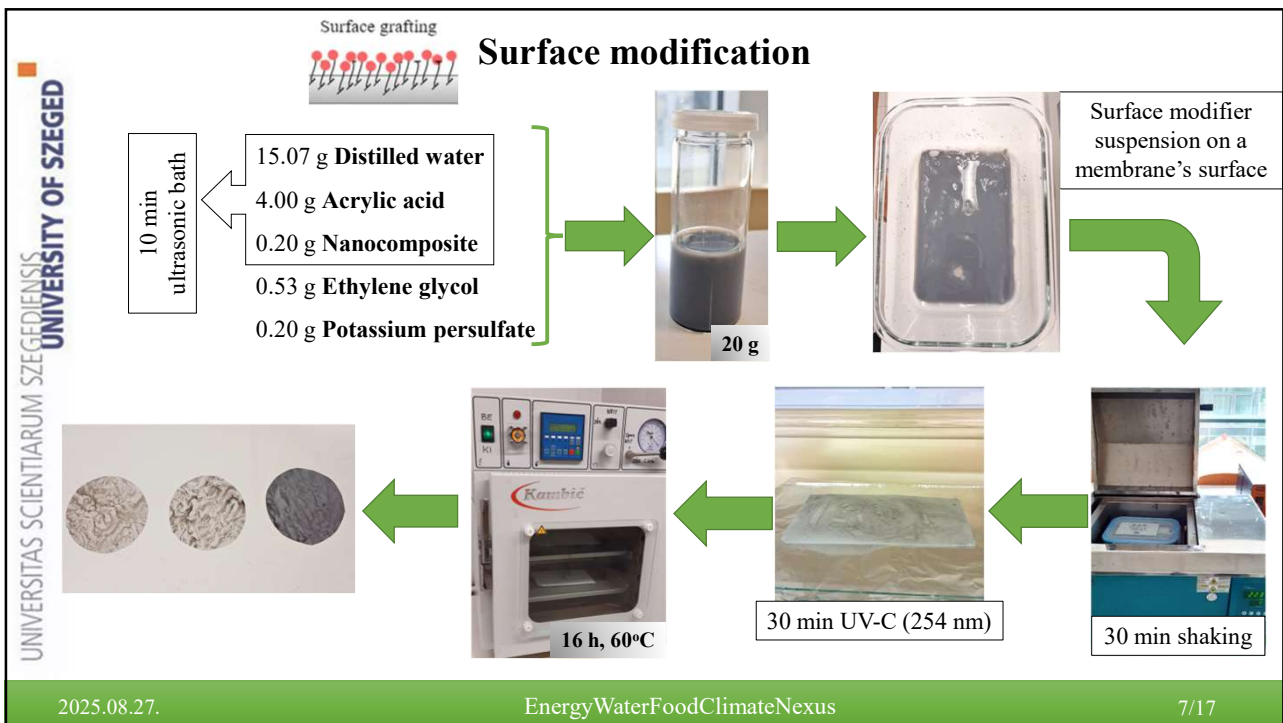
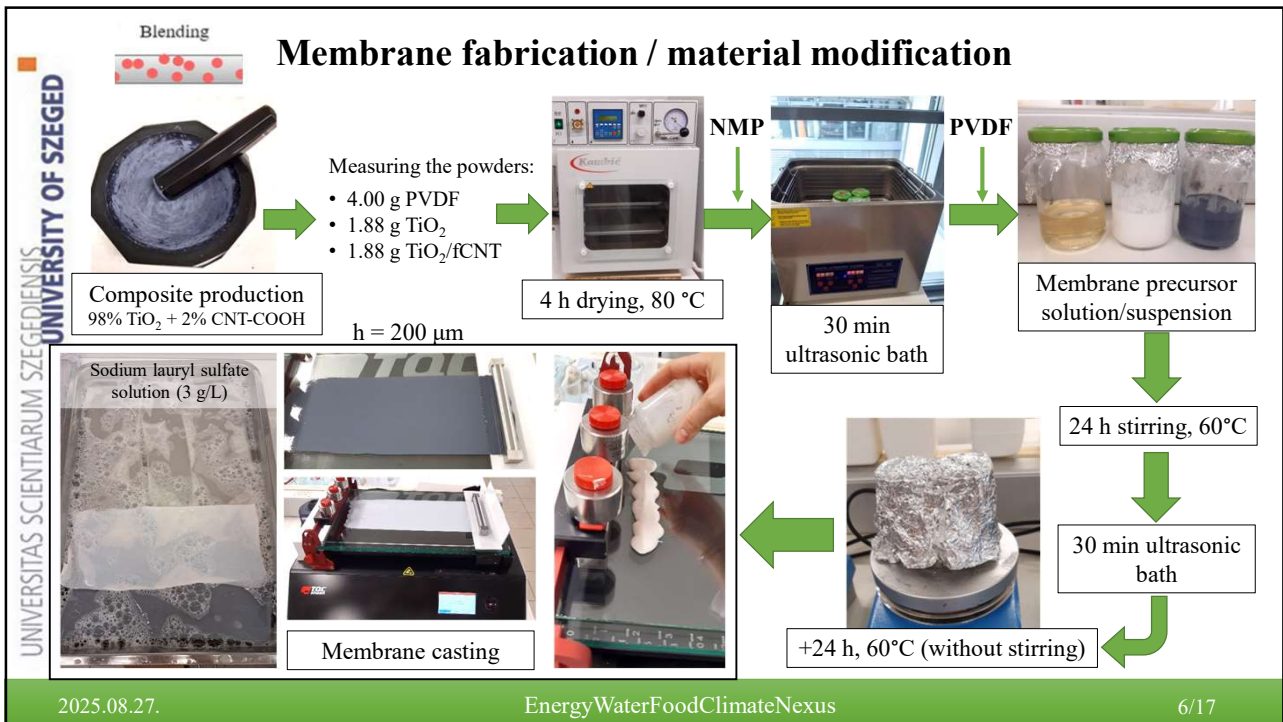

UNIVERSITAS SCIENTIARUM SZEGEDIENSIS  
**UNIVERSITY OF SZEGED**

## Quantities used for modifications



**Unmodified PVDF membrane:**

Component	Amount	
	[wt%]	[g]
PVDF por	11.5	4.0
NMP oldószer	88.5	30.9

**Material modification (blending):**

Precursor material:

Component	Amount	
	[wt%]	[g]
PVDF powder	10.88	4.00
Nanomaterial	5.11	1.88
NMP solvent	84.01	30.90

↓ Phase inversion

**Fabricated membrane:**

32% nanomaterial  
 68% PVDF

**Surface modification (grafting):**

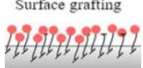

Component	Amount		
	[wt%]	[g]	[mL]
Distilled water	75.35	15.07	15.07
Acrylic acid	20.00	4.00	3.81
Nanocomposite	1.00	0.20	-
Ethylene glycol	2.65	0.53	0.48
Potassium persulfate	1.00	0.20	-



Heng et al., 2021  
Gokula et al., 2022

2025.08.27.
EnergyWaterFoodClimateNexus
8/17

UNIVERSITAS SCIENTIARUM SZEGEDIENSIS  
**UNIVERSITY OF SZEGED**

## RESULTS #1 TiO<sub>2</sub>/CNT-COOH surface modification

*VRR=Volume Reduction Ratio*

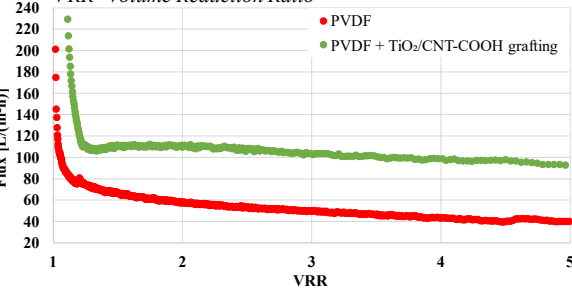

*FRR=Flux Recovery Ratio*

Membrane	Initial flux J <sub>DV</sub> [L/(m²h)]	Flux at VRR=5 J [L/(m²h)]	Flux after rinsing J <sub>DV</sub> [L/(m²h)]	FRR [%]
PVDF	4061.5	40.3	187.5	4.6
PVDF + TiO <sub>2</sub> /CNT-COOH grafting	1273.1	93.0	1126.0	88.5
TiO <sub>2</sub> blending	4489.0	71.2	1076.3	24.0
TiO <sub>2</sub> blending + TiO <sub>2</sub> /CNT-COOH grafting	3065.1	114.5	1409.3	46.0
TiO <sub>2</sub> /CNT-COOH blending	4805.7	80.7	1465.9	30.5
TiO <sub>2</sub> /CNT-COOH blending + TiO <sub>2</sub> /CNT-COOH grafting	2619.7	106.6	922.8	35.2

*VRR=Volume Reduction Ratio*

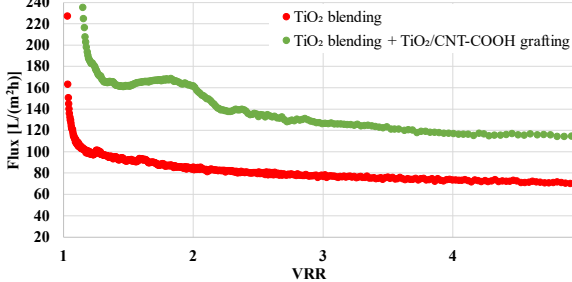

*VRR=Volume Reduction Ratio*

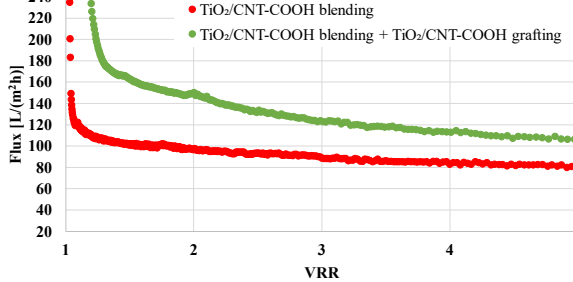

2025.08.27.
EnergyWaterFoodClimateNexus
9/17

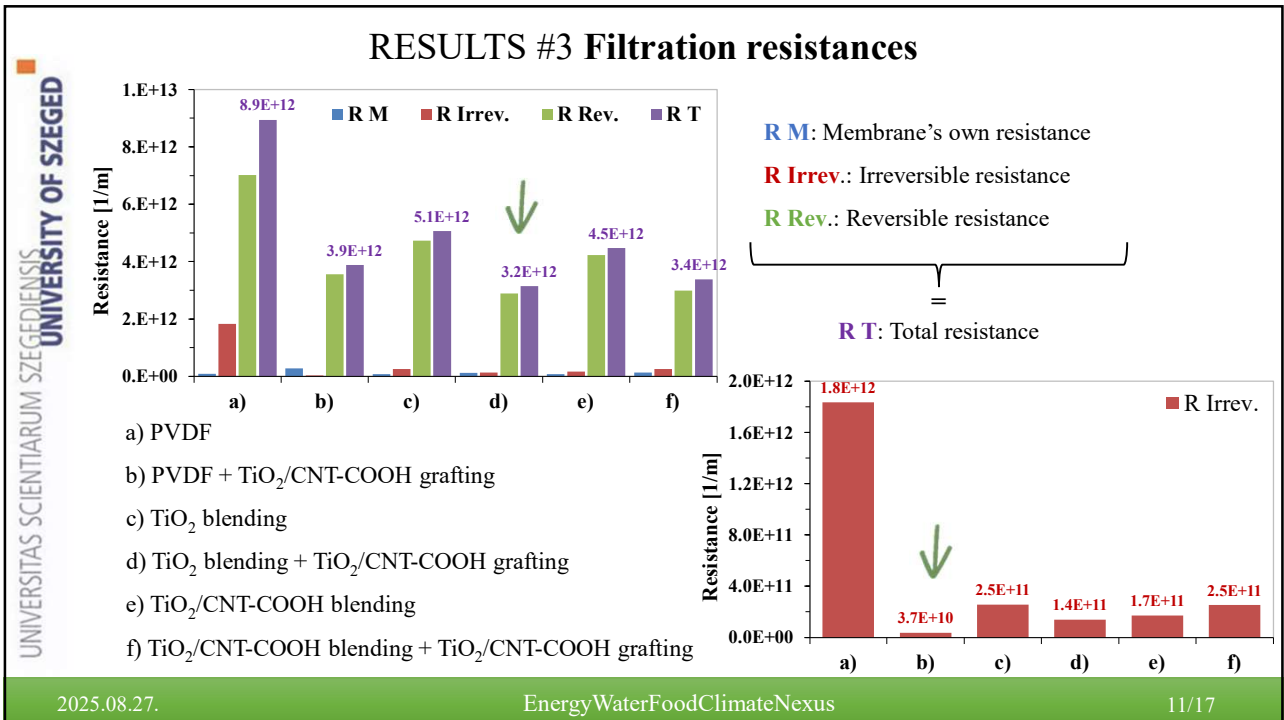
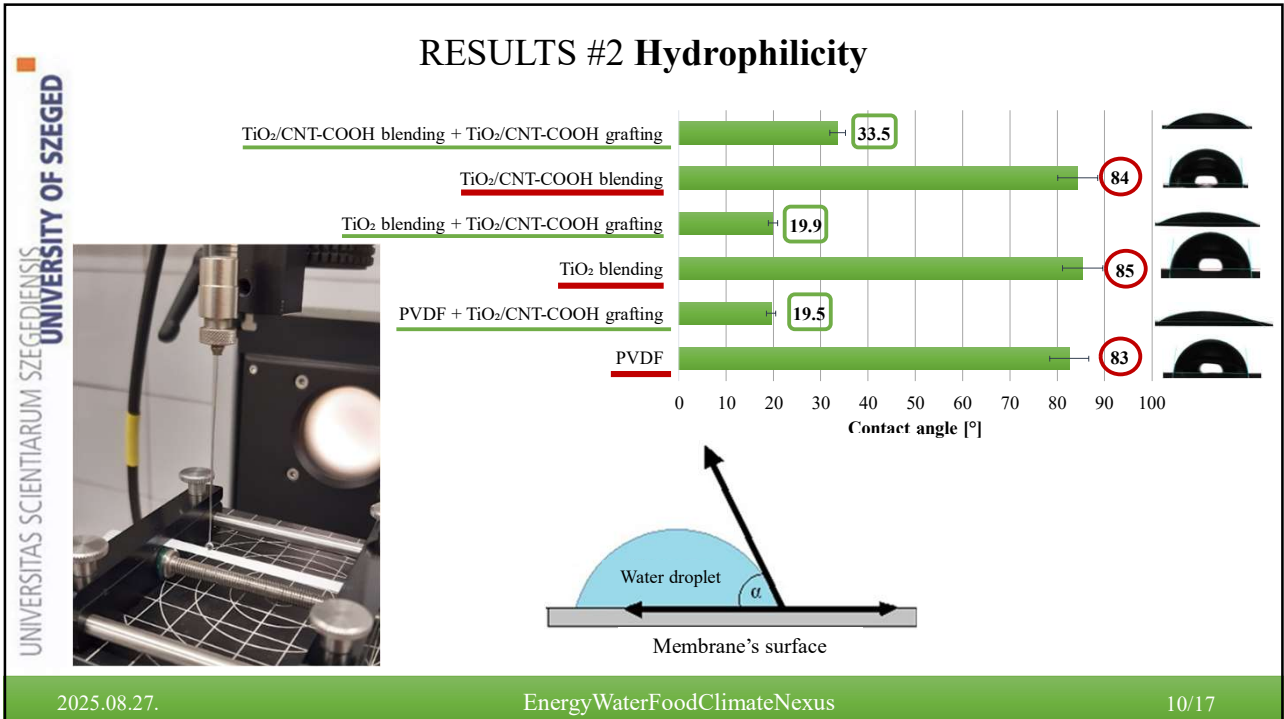

**RESULTS #4 Difficulties during material modification**

10 min ultrasonication



~~TiO<sub>2</sub>/CNT-COOH blending~~

30 min ultrasonication



Blending: TiO<sub>2</sub> ✓  
Grafting: TiO<sub>2</sub>/CNT-COOH

UNIVERSITAS SCIENTIARUM SZEGEDIENSIS UNIVERSITY OF SZEGED

2025.08.27. EnergyWaterFoodClimateNexus 12/17

**RESULTS #5 Different oil-in-water emulsions**

**FRR [%]**

Membrane	C oil	A oil	B oil
PVDF	21.2	4.6	11.8
PVDF + TiO <sub>2</sub> /CNT-COOH grafting	58.2	88.5	45.4

**PVDF membrane**

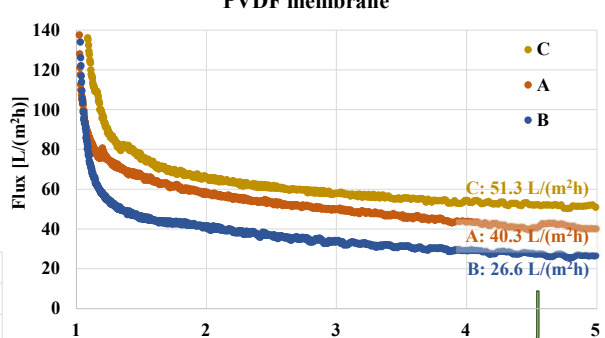

C: 51.3 L/(m<sup>2</sup>h)  
 A: 40.3 L/(m<sup>2</sup>h)  
 B: 26.6 L/(m<sup>2</sup>h)

**PVDF + TiO<sub>2</sub>/CNT-COOH grafting**

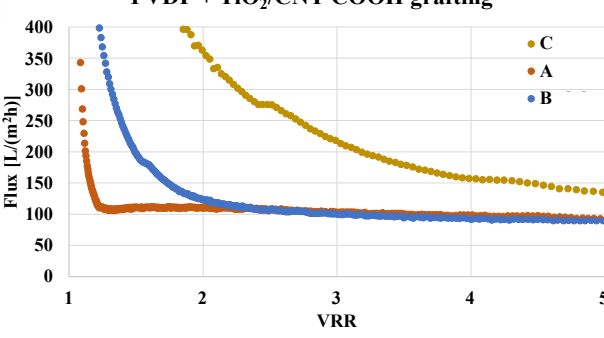

C: 135.8 L/(m<sup>2</sup>h)  
 A: 93.0 L/(m<sup>2</sup>h)  
 B: 90.1 L/(m<sup>2</sup>h)

Flux growth

C: 2.7x  
 A: 2.3x  
 B: 3.4x

UNIVERSITAS SCIENTIARUM SZEGEDIENSIS UNIVERSITY OF SZEGED

2025.08.27. EnergyWaterFoodClimateNexus 13/17

### RESULTS #6 Industrial wastewater

Membrane	FRR [%]	Turbidity of emulsion [NTU]	Turbidity of permeate [NTU]	$\eta$ [%]
TiO <sub>2</sub> blending + TiO <sub>2</sub> /CNT-COOH grafting	80.6		0.244	99.2
PVDF + TiO <sub>2</sub> /CNT-COOH grafting	33.6	30.0	0.181	99.4
PVDF	20.2		0.200	99.3

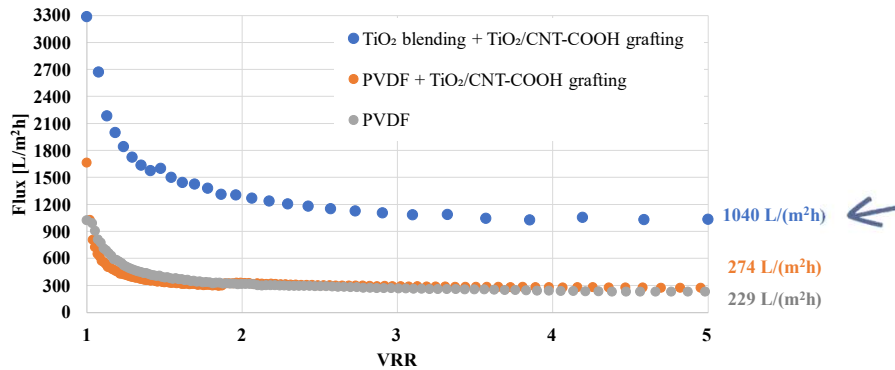

2025.08.27.

EnergyWaterFoodClimateNexus

14/17

### RESULTS #7 Photocatalytic regeneration

Filtration with industrial wastewater



$I_{UV-A} = 7 \text{ mW/cm}^2$

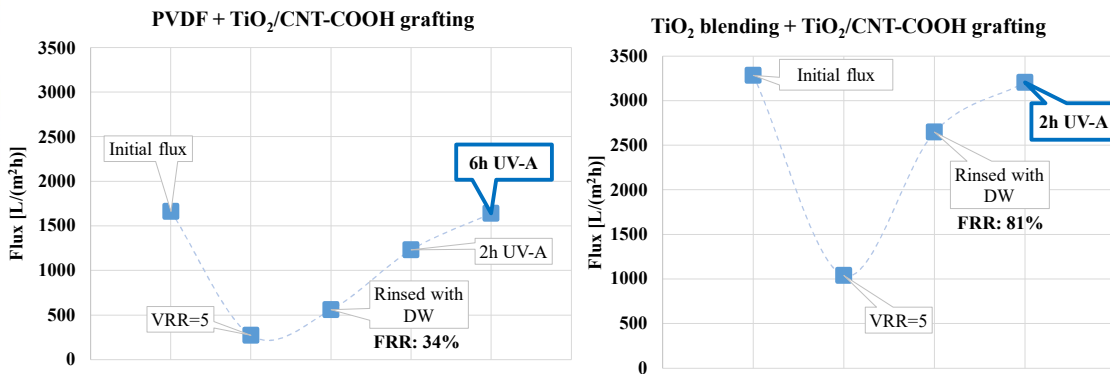



Industrial wastewater filtration again with UV-regenerated membranes:  $\eta \sim 99\%$

2025.08.27.

EnergyWaterFoodClimateNexus

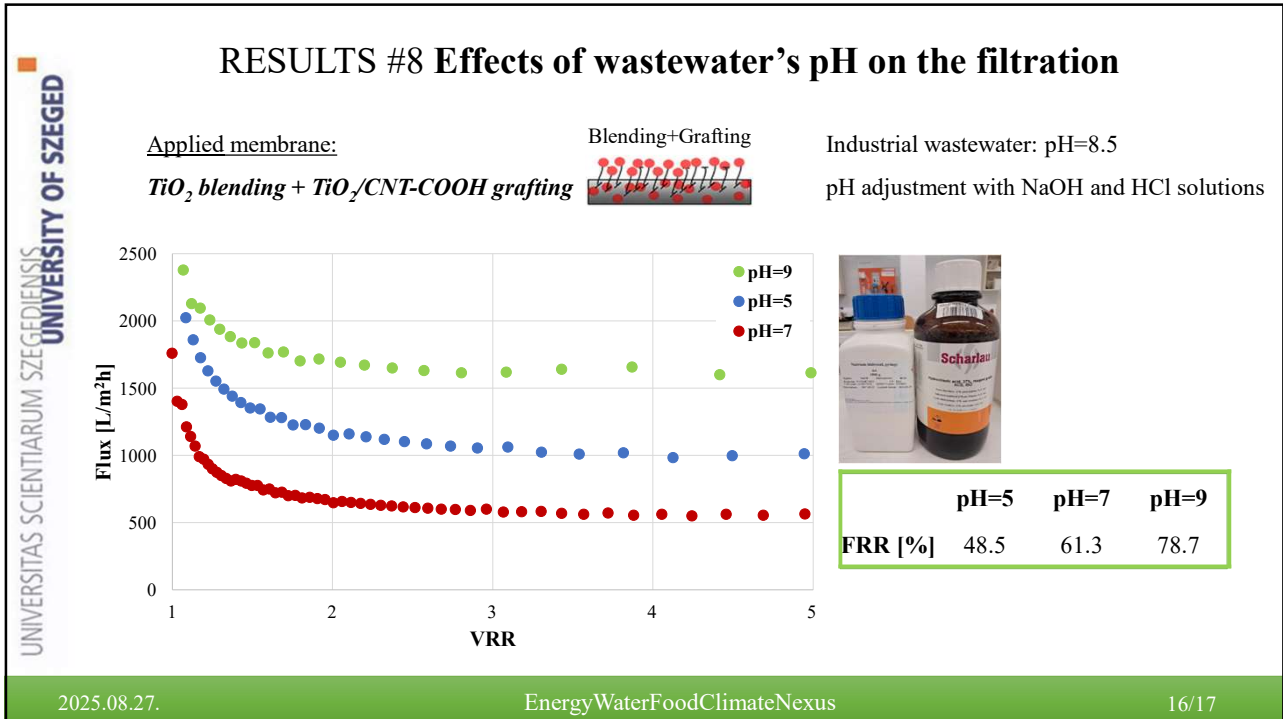
15/17





## SUMMARY

TiO<sub>2</sub>/CNT-COOH<sub>2%</sub> composite wasn't suitable for blending modification, however it was beneficial in several aspects for surface modification, even in the case of different oil compounds:

- ✓ Surface modified membranes were **less clogged**, both **flux values (2-5x)** and **flux recoveries (1,5-19x)** were significantly higher;
- ✓ The contact angle can be reduced by **up to a quarter**, making the surface much more hydrophilic;
- ✓ Irreversible resistance has become **one or two orders of magnitude lower**;
- ✓ The membrane **can be regenerated without chemicals** in a few hours by UV-A irradiation, so the surface is photocatalytically **active**;
- ✓ Alkaline pH condition was the most advantageous.



2025.08.27.
EnergyWaterFoodClimateNexus
17/17

## ACKNOWLEDGEMENT

- I would like to thank my supervisor, Dr. Gábor Veréb for his professional support;
- I thank University of Miskolc for the award given to me in the 37th OTDK;
- The research was funded by the Hungarian National Research, Development and Innovation Office - NKFIH under the „Development and application of nanoparticle modified membranes for the efficient treatment of oil-contaminated waters” project (NKFI\_FK\_20\_135202);
- The research was carried out with the professional support of the University Research Scholarship Program of the Ministry of Culture and Innovation, financed by the National Research, Development and Innovation Fund (EKÖP-268)



2025.08.27.

EnergyWaterFoodClimateNexus



**MISKOLCI**  
EGYETEM  
UNIVERSITY OF MISKOLC

## Thank you for your kind attention!

### Literature:

- Fekete L, Fazekas ÁF, Hodúr C, László Z, Ágoston Á, Janovák L, Gyulavári T, Pap Z, Hernádi K, Veréb G. (2023): Outstanding Separation Performance of Oil-in-Water Emulsions with TiO<sub>2</sub>/CNT Nanocomposite-Modified PVDF Membranes. *Membranes* 13(2):209 (<https://doi.org/10.3390/membranes13020209>)
- Fazekas, Á. F., Gyulavári, T., Pap, Z., Bodor, A., Laczi, K., Perei, K., Illés, E., László, Z., Veréb, G. (2023): Effects of Different TiO<sub>2</sub>/CNT Coatings of PVDF Membranes on the Filtration of Oil-Contaminated Wastewaters. *Membranes* 13, 812. (<https://doi.org/10.3390/membranes13100812>)
- Gao B., Chen G. Z., Li P. G. (2009): Carbon nanotubes/titanium dioxide (CNTs/TiO<sub>2</sub>) nanocomposites prepared by conventional and novel surfactant wrapping sol-gel methods exhibiting enhanced photocatalytic activity. *Applied Catalysis B: Environmental* 89 (3-4), 503-509. (<https://doi.org/10.1016/j.apcatb.2009.01.009>)
- Gokula Krishnan S. A., Sasikumar B., Arthanaswaram G., László Zsuzsanna, Erika Nascimben Santos, Veréb Gábor, Kertész Szabolcs (2022): Surface-initiated polymerization of PVDF membrane using amine and bismuth tungstate (BWO) modified MIL-100(Fe) nanofillers for pesticide photodegradation. *Chemosphere* 304, 135286. (<https://doi.org/10.1016/j.chemosphere.2022.135286>)
- Heng Z.W., Chong W.C., Pang Y.L., Koo C.H. (2021): Self-assembling of NCQDs-TiO<sub>2</sub> nanocomposite on poly(acrylic acid)-grafted polyethersulfone membrane for photocatalytic removal and membrane filtration. *Materials Today Proceedings* 46 (5), 1901–1907. (<https://doi.org/10.1016/j.matpr.2021.02.021>)
- Kovács I., Veréb G., Kertész S., Hodur C., László Z. (2018): Fouling mitigation and cleanability of TiO<sub>2</sub> photocatalyst-modified PVDF membranes during ultrafiltration of model oily wastewater with different salt contents. *Environmental Science and Pollution Research* 25 (35), 34912-34921. (<https://doi.org/10.1007/s11356-017-0998-7>)
- Leong S., Razmjou A., Wang K., Hapgood K., Zhang X., Wang H. (2014): TiO<sub>2</sub> based photocatalytic membranes: A review. *Journal of Membrane Science* 472, 167-184. (<https://doi.org/10.1016/j.memsci.2014.08.016>)
- Li X. Z., Liu H., Cheng L. F., Tong H. J. (2003): Photocatalytic oxidation using a new catalyst TiO<sub>2</sub> microsphere for water and wastewater treatment. *Environmental Science & Technology* 37, 3989–3994. (<https://doi.org/10.1021/es0262941>)
- Veréb G., Kálmán V., Gyulavári T., Kertész S., Beszédés S., Kovács G., Hernádi K., Pap Z., Hodúr C., László Z. (2019): Advantages of TiO<sub>2</sub>/carbon nanotube modified photocatalytic membranes in the purification of oil-in-water emulsions. *Water Supply* 19 (4), 1167-1174. (<https://doi.org/10.2166/ws.2018.172>)

2025.08.27.

EnergyWaterFoodClimateNexus

### RESULTS #+1 Droplet size distribution

Malvern ZetaSizer Nano ZS

“A” oil

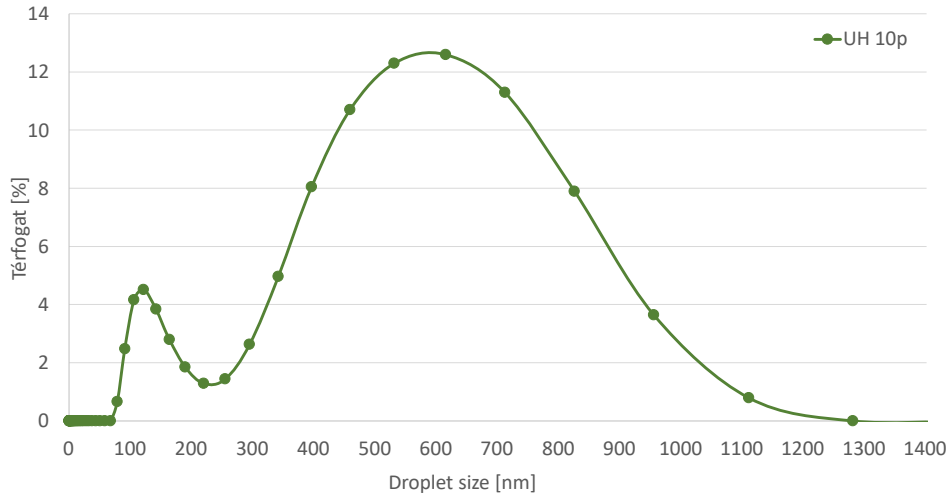

### RESULTS #+1 Oil droplet distribution/pore size

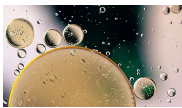

$\eta_{10p} = 99,9\%$

$\eta_{30p} = 93,1\%$

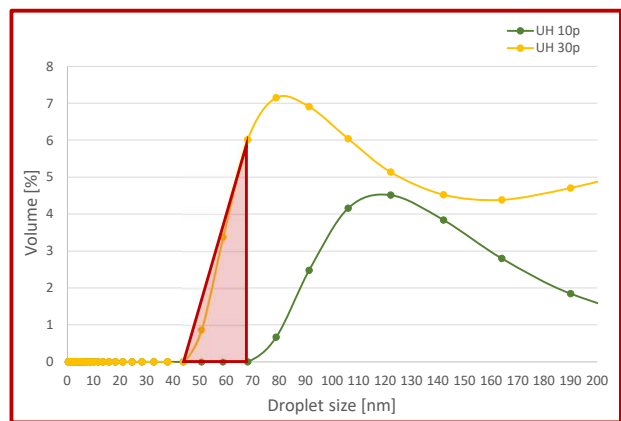
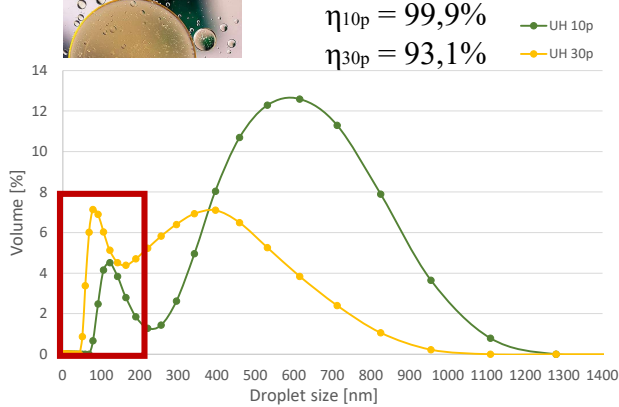

*TiO<sub>2</sub>-Blending-TiO<sub>2</sub>-Grafting*  
 biggest pore size of the membrane:  $d \leq 70 \text{ nm}/0,07 \mu\text{m}$

Instrument:  
 Malvern ZetaSizer Nano ZS

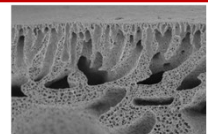

**DETEP**  
Debreceni Egyetem  
Tehetséggondozó Program



# The edibility of microgreens grown on greywater

Made by: Gyöngyüér Boglárka Nusser<sup>1</sup>, Andrea Izbéki-Szabolcsik<sup>2</sup>,

<sup>1,2</sup> Department of Environmental Engineering, Faculty of Engineering,  
University of Debrecen, Óttemető u. 2-4., Debrecen

ENERGYWATERFOODCLIMATE  
**NEXUS**  
INTERNATIONAL SUMMIT

AUGUST 26-28, 2025  
EUROPE  
MISKOLC, HUNGARY

# Overview

- Microgreens
- Greywater
- Material and methods
- Results
- Conclusion
- Summary

## Microgreens

- Young plants, with matured cotyledons
- Growth time:
  - 5-21 days, 7-10 days
- Needs for growth:
  - seed, water, sunshine
- Nutrients:
  - Vitamins, minerals, antioxidants



## Greywater

- Water types:



Drinking/clean water



Greywater (GW)



Blackwater (BW)



4

## Material and methods



Tap water (TW)



Untreated greywater (UTGW)



Treated Greywater (TGW)

## Material and methods

### • Water quality indicators:

- pH
- Turbidity
- Conductivity
- Zeta potential
- Organic matter content

### • Crops quality indicators:

- Mass and length measurement
- Moisture content
- Elemental analysis

## Material and methods

### Studied plants:

- **Wheat**
- Broccoli
- Alfalfa
- **Red cabbage**

### Edibility:

- THQ and HI value

$$THQ = \frac{EF \times ED \times IR \times Cm \times 10^{-3}}{RfD \times BW \times TA}$$

$$HI = \sum THQ$$

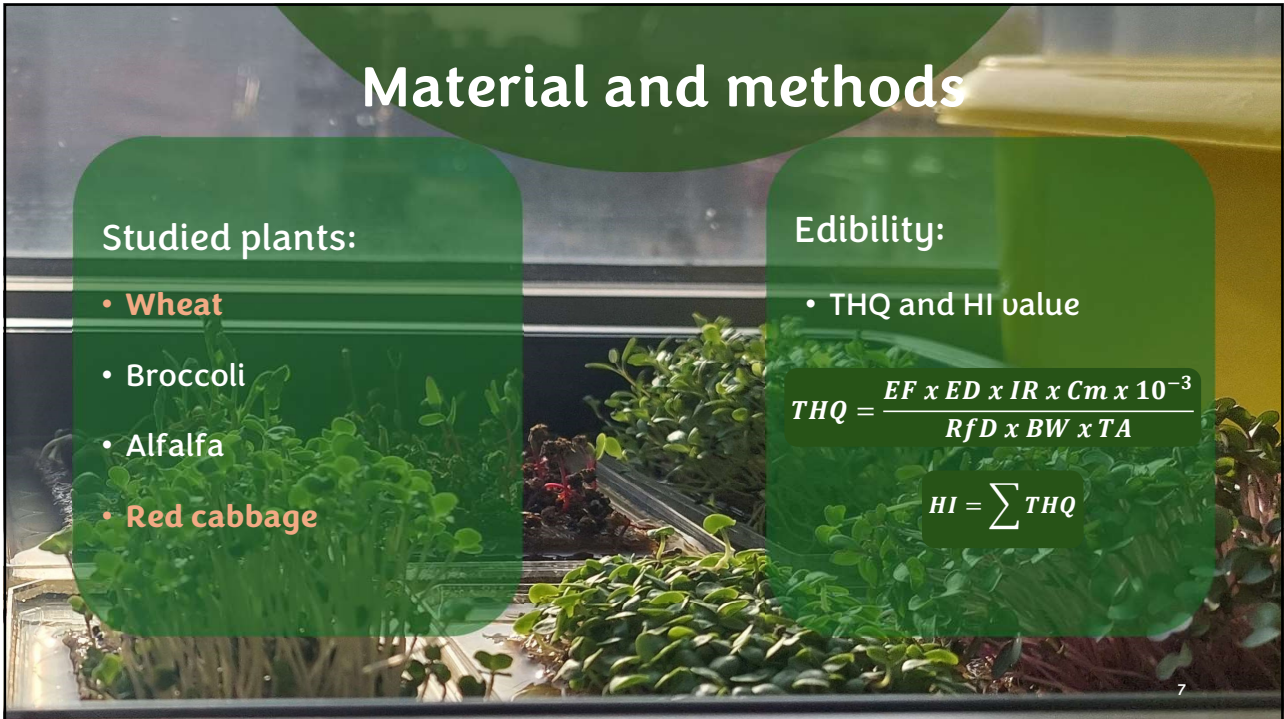

## Results

- Waters:

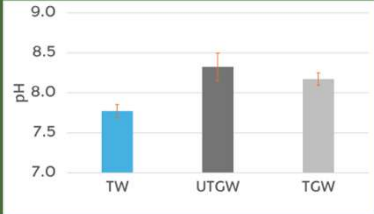

Water Type	pH
TW	~7.8
UTGW	~8.3
TGW	~8.1

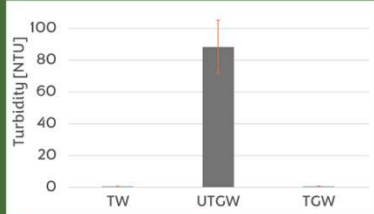

Water Type	Turbidity [NTU]
TW	~0
UTGW	~85
TGW	~0

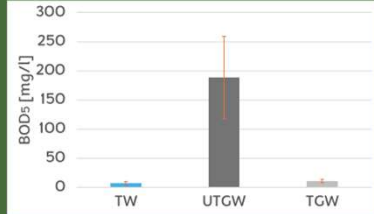

Water Type	BOD5 [mg/l]
TW	~0
UTGW	~180
TGW	~0

	pH	Turbidity	BOD5
Limit value*	6-9	Average 2, Max. 5 NTU	<25 mg/l

\*The European Parliament and the Council, Regulation EU 2020/741, Minimum requirements for water reuse Eur. Comm. , 2020, The European Parliament and the Council Regulation EU /741, Minimum requirements for water reuse, 20202019 (EU 2020/741 Category B). USEPA (United States Environmental Protection Agency), 2004. Guidelines for Water Reuse. Report EPA/625/R-04/108, USEPA, Washington, DC, USA. Winward et al. A study of the microbial quality of grey water and an evaluation of treatment technologies for reuse, ecological engineering 32 (2008) 187-197

# Results

## Wheat



	TW	UTGW	TGW
Number of plants	77	82	72
Average height [cm]	7.29 ± 2.50	12.12 ± 4.10	10.02 ± 2.78
Mass of wet biomass [g]	3.67	6.43	4.70

9

# Results

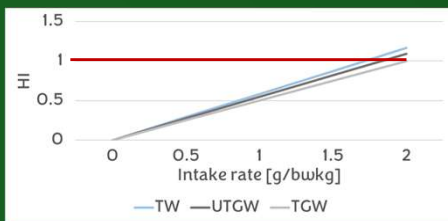
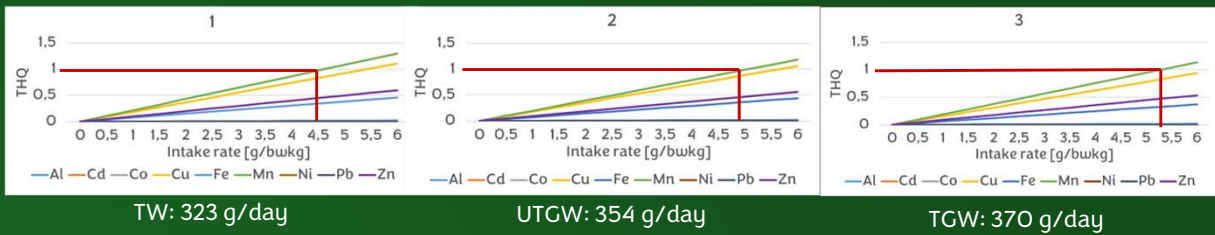

- HI:
- TW: 124 g/day
  - UTGW: 128 g/day
  - TGW: 140 g/day

10

# Results

## Red cabbage



	TW	UTGW	TGW
Number of plants	20	20	20
Average height [cm]	2.44 ± 0.54	2.52 ± 0.62	3.01 ± 0.72
Mass of wet biomass [g]	3.80	3.51	6.10

11

# Results

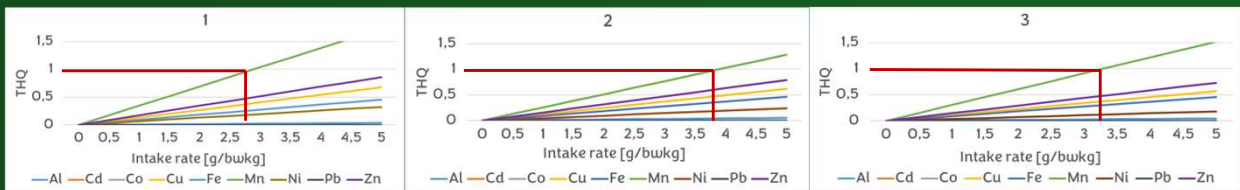

TW: 203 g/day

UTGW: 273 g/day

TGW: 231 g/day

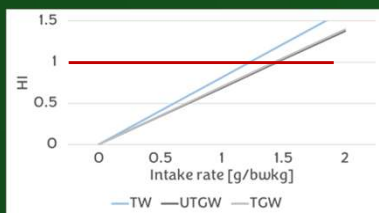

- HI:
- TW: 86 g/day
  - UTGW: 102 g/day
  - TGW: 100 g/day

12

**• Conclusion**

- The edibility was **not drastically affected** by the use of greywater
- The mass of the plants were
- The results are plant specific

13

**Review**

	Wheat		Broccoli	
	UTCW	TGW	UTCW	TGW
Edibility	+	++	-	+
Growth	++	+	++	+

	Alfalfa		Red cabbage	
	UTCW	TGW	UTCW	TGW
Edibility	+	++	++	+
Growth	--	-	-	+

14

## **Acknowledgements**

We would like to thank Dr. Edina Baranyai and Dr. Zsofi Sajtos for their help in the analysis of the water and plant samples at the Environmental Analysis Laboratory of the Department of Inorganic and Analytical Chemistry, University of Debrecen.

**Thank you for your attention!**

15

## Heat conduction in a rotating body *On the example of a bicycle disc brake*



Made by: RITTGASSZER TAMÁS

CONSULTANT: *Dr. Szücs Mátyás*  
*adjunct*

ENERGY WATER FOOD CLIMATE NEXUS – 2025  
MISKOLC, 2025. AUGUST 26-28.

### Rotating systems with thermal processes



- Friction
- Plastic deformation
- Electrical resistance



## Analysing these systems

### The advantages of measurement

- More accurate
- Easily repeatable
- We can compare different brakes
- We can compare the effects of the brake parts

### The advantages of simulation

- Much faster
- Much cheaper (on the long run)
- Less labor-intensive, space intensive

## Heating up of brakes- overview

### Why is it a problem, that it is heating up?

- Temperature dependency of brake performance
- It could cause the degradation of brake parts
- It could cause the brake fluid, to boil up



## The purpose of my measurements and simulation

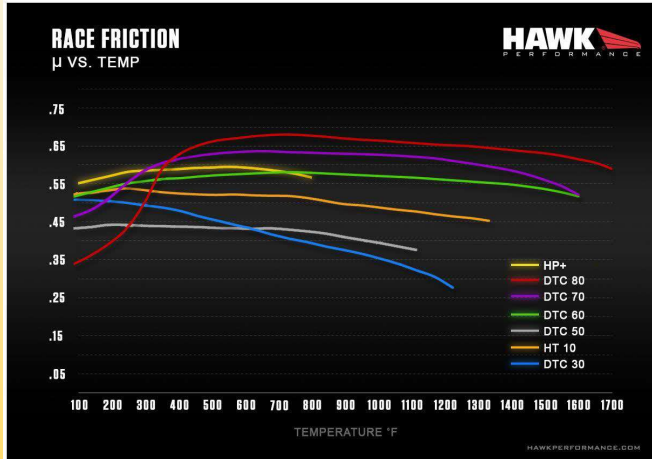

### The purpose of the measurement

- Measuring the change of brake performance
- Measuring the heating up, and cooling down of the brake

### The purpose of the simulation

- Simulating the heating up, and cooling down of the brake
- Comparing with the measurement

## Measurement layout



- *TACX flow T2200* trainer
- *Raytek MI3* spot thermal camera
- K-type thermocouple (for calibration)



## Mechanical background of the measurement

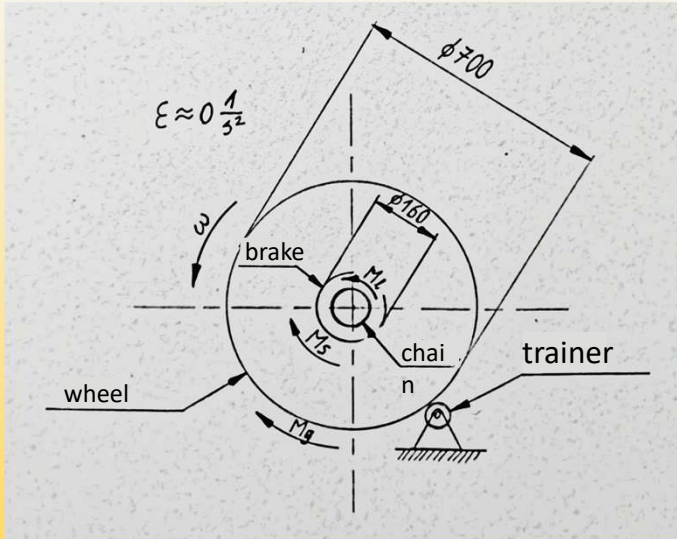

- Constant angular velocity
- Power balance
  - Power on chain (measured)
  - Power on trainer (constant)
  - Power on brake (unknown)
  - $P_t + P_b = P_c$
- → From this, we can calculate the torques

## Results

### Brake torque

- $\approx$  constant
- Probably because of the not high enough temperature
- The measurement principle looks correct

### Temperature

- Later...

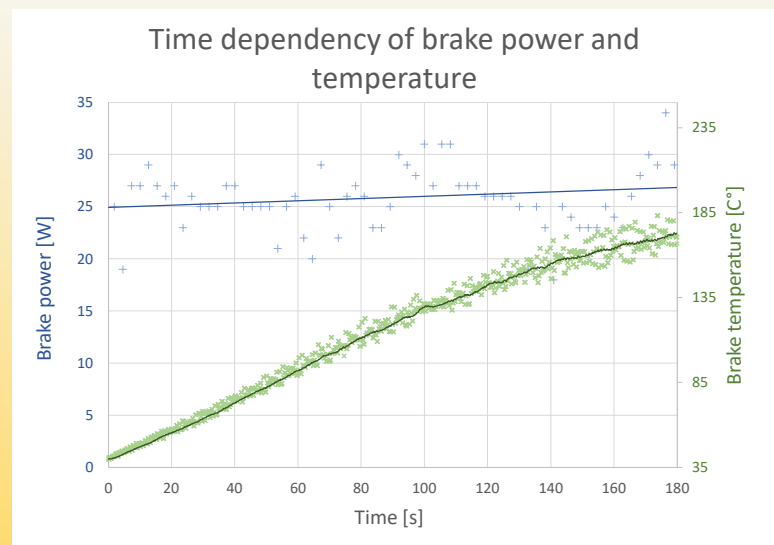

## Numerical simulation – The base of the modell

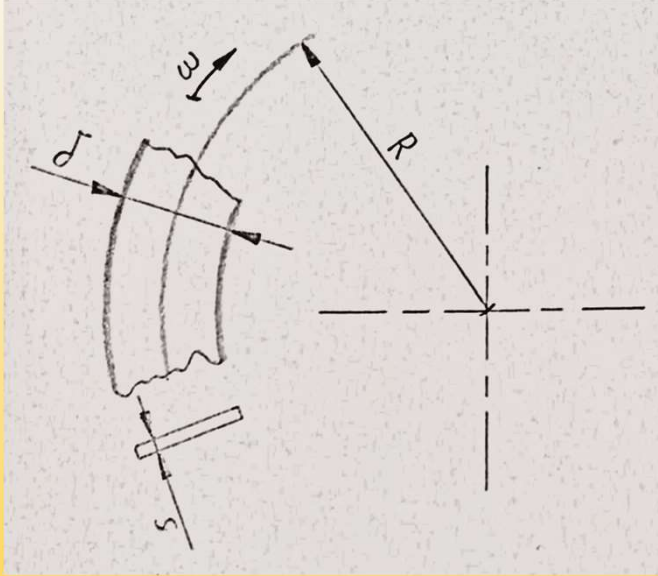

- Constant angular velocity
- Effective one spatial dimension
- Braking (heat source)
- Air cooling (heat transfer)

## Differential equation

The differential equation for heat conduction in a moving solid body:

$$\rho c \frac{DT}{Dt} = -\nabla \cdot \underline{\dot{q}} + q_V^* + q_S^*$$

$$\frac{DT}{Dt} = \frac{\partial T}{\partial t} + \nabla T \cdot \underline{v} \quad \text{time derivate (local + convective change of temperature)}$$

$$q_S^* \quad \text{the thermal power of the braking}$$

$$q_V^* \quad \text{the cooling of the disc brake}$$

$$\underline{\dot{q}} = -\lambda \cdot \nabla T \quad \text{heat flow (according to Fourier's law)}$$

## Transforming the equation

Surface integral → Volume integral

$$-2 \int_{(A)} \alpha \cdot (T - T_{\infty}) dA = \int_{(V)} \frac{-2}{s} q_{\alpha}^* dV \rightarrow q_V^* = \frac{-2}{s} \alpha \cdot (T - T_{\infty})$$

Effective one spatial dimension → simplifications (non vector equation)

→ Second-order partial differential equation

$$\frac{\partial T}{\partial t} + \frac{\partial T}{\partial \varphi} \omega = \frac{a}{R^2} \frac{\partial^2 T}{\partial \varphi^2} - \frac{2}{s \cdot \rho \cdot c} \alpha \cdot (T - T_{\infty}) + \frac{1}{\rho \cdot c} q_S^*$$

## Dimensionless differential equation system

Dimensionless quantities:

$$Fo := \frac{a \cdot t}{R^2}$$

$$\frac{\partial}{\partial t} = \frac{a}{R^2} \frac{\partial}{\partial Fo}$$

$$\vartheta := \frac{T - T_{\infty}}{T_{\infty}}$$

Dimensionless parameters:

$$C_1 := \omega \frac{R^2}{a}$$

$$C_2 := \frac{R^2}{a \cdot \rho \cdot c \cdot T_{\infty}} q_S^*$$

$$C_3 := \frac{2 \cdot R}{s}$$

$$Bi := \frac{R}{\lambda} \alpha$$

→ First-order differential equation system (with the introduction of **dimensionless heat flow**)

$$\frac{\partial \vartheta}{\partial Fo} + C_1 \chi = \frac{\partial \chi}{\partial \varphi} - C_3 \cdot Bi \cdot \vartheta + C_2$$

$$\chi = \frac{\partial \vartheta}{\partial \varphi}$$

## Discretization

Time-advanced, space-central, half-shifted, finite discretization

$$\frac{\partial \vartheta}{\partial Fo} (t^j, \varphi_n) \approx \frac{\vartheta_n^{j+1} - \vartheta_n^j}{\Delta Fo}$$

$$\frac{\partial \vartheta}{\partial \varphi} (t^j, \varphi_{n+\frac{1}{2}}) \approx \frac{\vartheta_{n+1}^j - \vartheta_n^j}{\Delta \varphi}$$

$$\frac{\partial \chi}{\partial \varphi} (t^j, \varphi_n) \approx \frac{\chi_{n+\frac{1}{2}}^j - \chi_{n-\frac{1}{2}}^j}{\Delta \varphi}$$

Explicit Euler method

$$\vartheta_n^{j+1} = \vartheta_n^j - \frac{\Delta Fo \cdot C_1}{2} \left( \chi_{n-\frac{1}{2}}^j + \chi_{n+\frac{1}{2}}^j \right) + \frac{\Delta Fo}{\Delta \varphi} \left( \chi_{n+\frac{1}{2}}^j - \chi_{n-\frac{1}{2}}^j \right) - \Delta Fo \cdot Bi \cdot \vartheta_n^j + \Delta Fo \cdot C_2$$

$$\chi_{n+\frac{1}{2}}^{j+1} = \frac{1}{\Delta \varphi} \left( \vartheta_{n+1}^{j+1} - \vartheta_n^{j+1} \right)$$

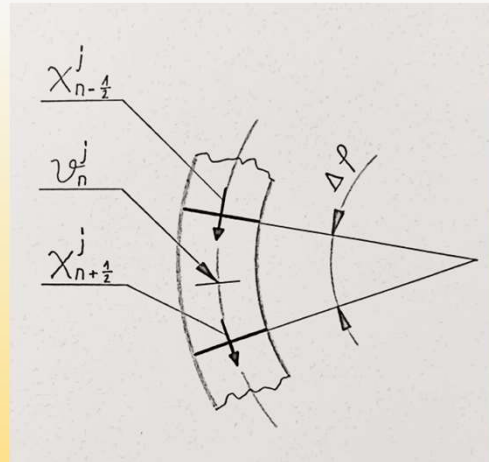

## Initial and boundary conditions

Homogenous temperature distribution

$$\vartheta_n^0 = \frac{T_0 - T_\infty}{T_\infty}$$

$$\chi_{n+\frac{1}{2}}^j = 0$$

Periodic boundary condition (in every time step)

$$\vartheta(Fo; 0) = \vartheta(Fo; 2\pi)$$

$$\chi(Fo; 0) = \chi(Fo; 2\pi)$$

## Determining parameters

Some can be determined from measurement circumstances

$$C_1 := \omega \frac{R^2}{a} = 5150$$

$$C_2 := \frac{R^2}{a \cdot \rho \cdot c \cdot T_\infty} q_S^* = 3,7 \cdot 10^{-7} \cdot q_S^*$$

$$C_3 := \frac{2 \cdot R}{s} = 72$$

$$Bi := \frac{\alpha \cdot R}{\lambda} = 1,57 \cdot 10^{-3} \cdot \alpha$$

Parameters to be fit

Thermal power of braking:

$$q_S^* = 10^{8,2} \left[ \frac{W}{m^3} \right]$$

Heat transfer coefficient:

$$\alpha = 10^{1,75} \frac{W}{m^2 K} \approx 56 \frac{W}{m^2 K}$$

## Simulation results

First measurement (partly)

- For defining parameters

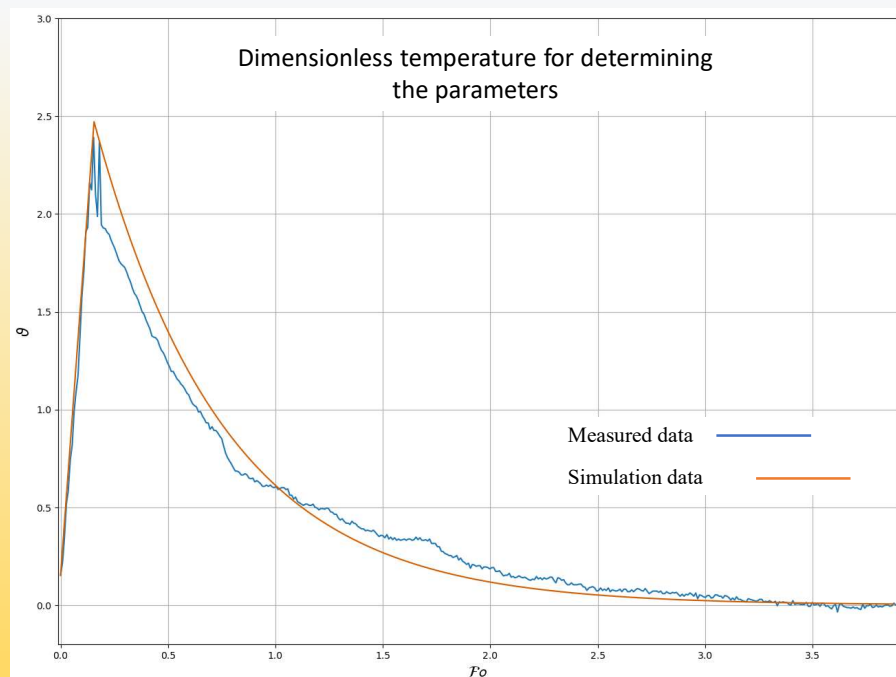

### Second measurement

- Measurement error
- Warming characteristic

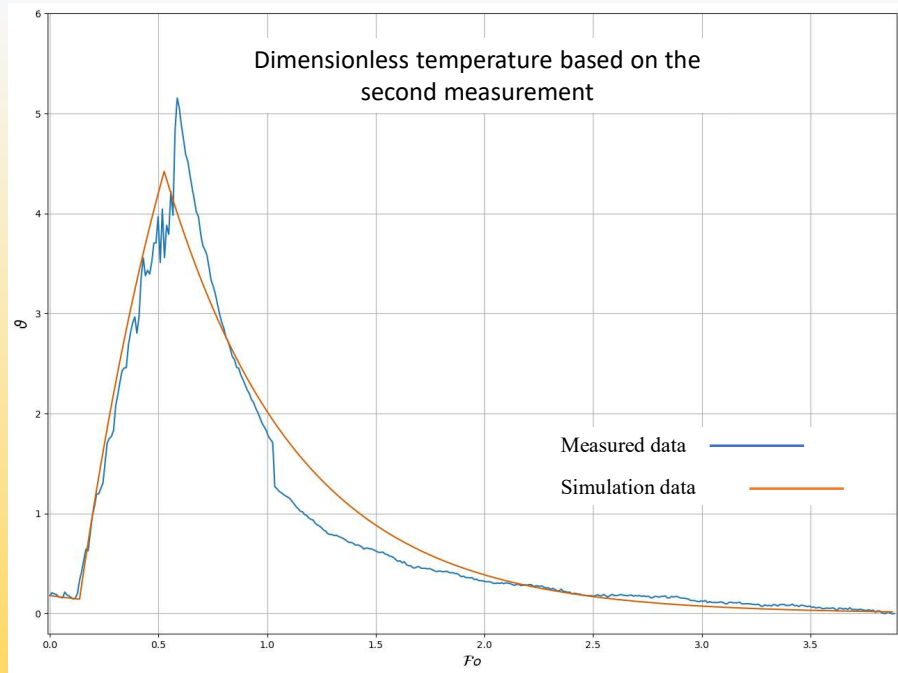

### First measurement (whole)

- More complicated

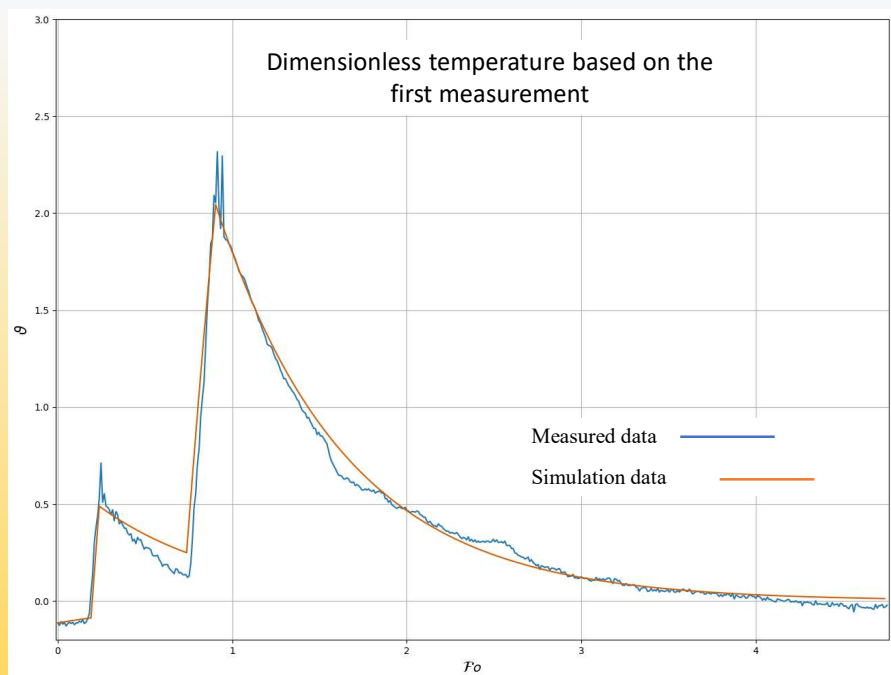

## Expanding the topic

### Measurement

- High resolution thermal camera
- Higher temperature measurements
- Designing a measuring equipment

### Data processing

- 

### Simulation

- Fitting the parameters automatically
- Testing the sensitivity
- Expanding the model
  - Temperature dependent quantities

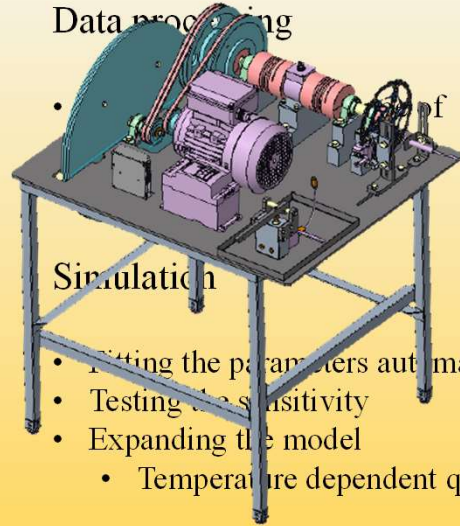

**Thank you for your  
attention!**

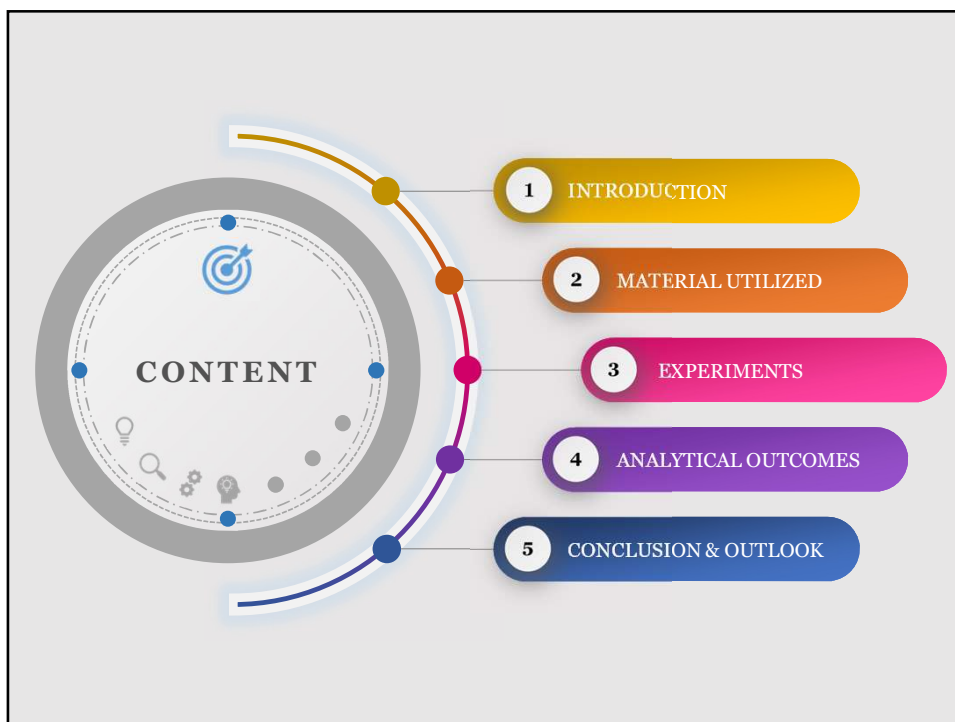
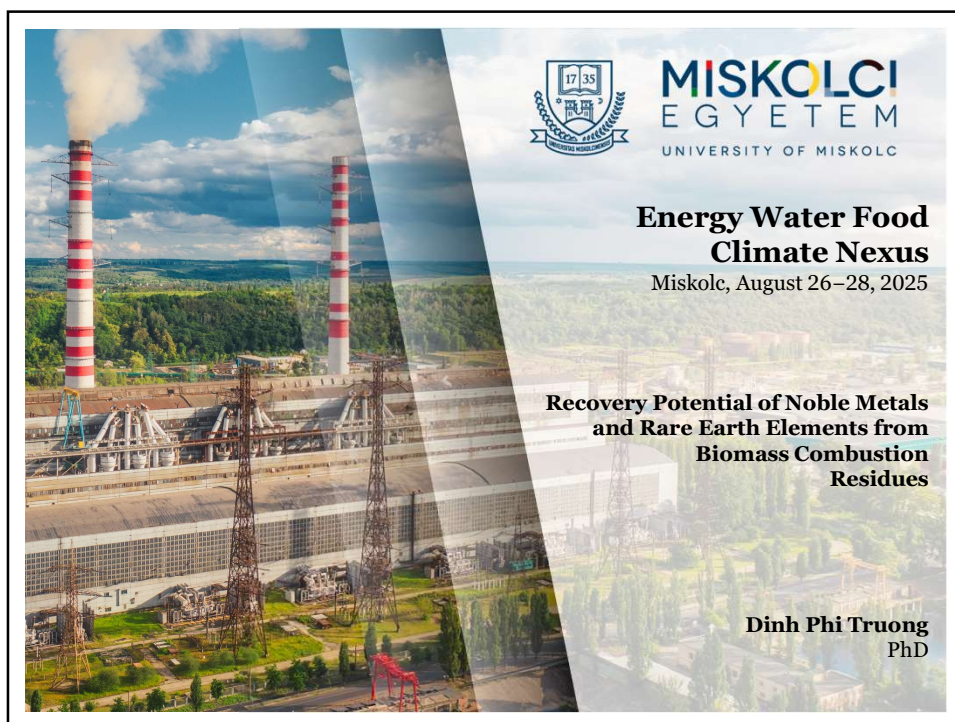

## INTRODUCTION

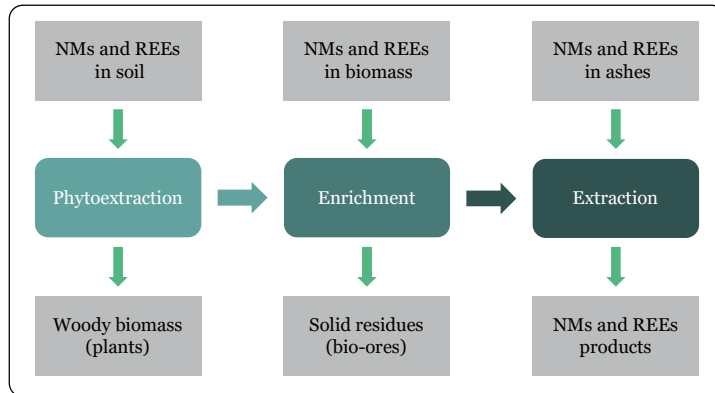

- ❖ **Study:** Enrichment of noble metals (NMs) and rare earth elements (REEs) in solid burning residues coming from biomass combustion.
- ❖ **Goals:** Investigate the enrichment of NMs and REEs by combustion and ash leaching techniques utilizing pelletized woody biomass used as fuel, while describing the behavior and depicting the formation of high-value metals in the combustion system is supported by ICP and SEM methodologies.

## SAMPLING LOCATION



## BIOMASS SAMPLING



## EXPERIMENTAL SYSTEM

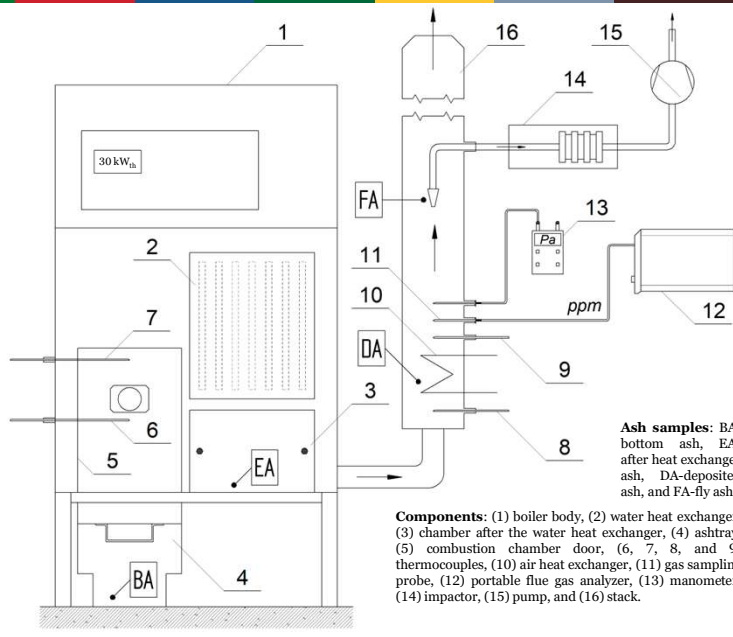

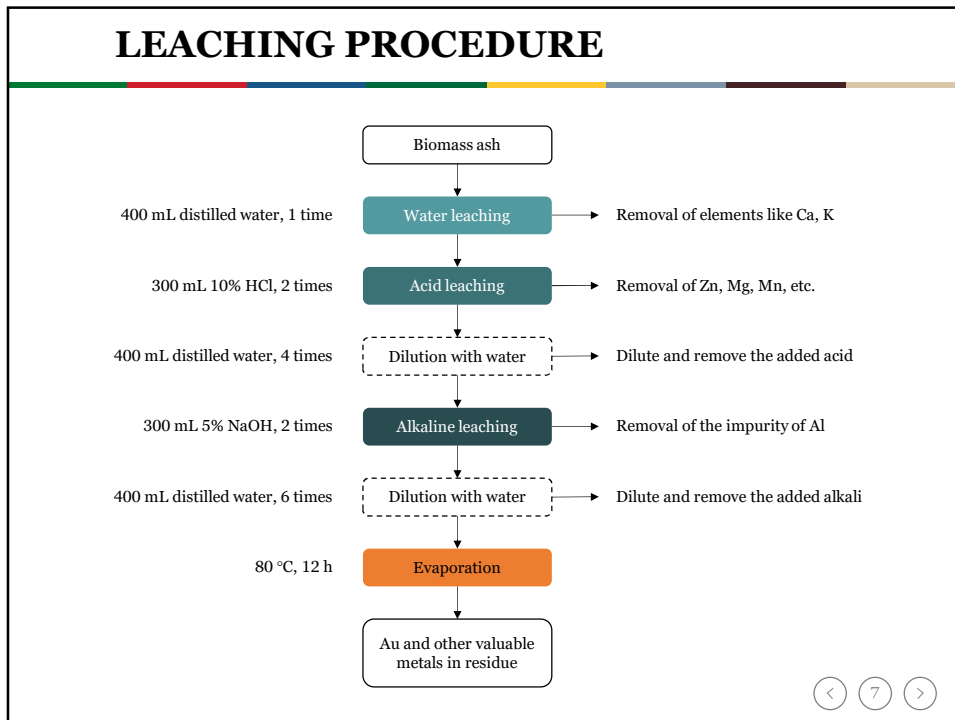

### ICP ANALYSIS

#### Concentrations of NMs and REEs in solid samples (mg/kg)

Metal	Biomass	Biomass combustion ashes				Leaching residues		
	WB	BA	HXA	DA	FA	LB	LHX	LD
Ag	<0.5	2.94	8.32	17.13	18.87	14.2	21.5	13.1
Au	<0.05	1.52	1.99	2.64	3.52	12.1	<4	12.6
Ce	0.526	5.85	4.08	2.40	<1.5	3.01	2.36	<5
Dy	<1	2.27	1.61	<1	<3	<4	<4	<10
Gd	0.026	7.02	4.30	2.49	<1.5	<2	<2	<5
La	<0.25	4.76	2.99	1.69	<1	1.89	1.02	<3
Nd	<0.5	32.10	19.43	8.01	<3	54.9	20	11.7
Sc	<0.01	0.35	0.38	<0.25	<1	<1	<1	<3
Sm	0.026	3.83	2.16	0.79	<1.5	<2	<2	<5
Y	<0.25	2.87	1.95	1.13	<1	1.05	0.404	<1

"<": Below the detection limit; WB: Woody biomass; BA, HXA, DA, and FA: Bottom ash, after heat exchanger ash, deposited ash, and fly ash, respectively; LB, LHX, and LD: leaching residues derived from leaching of bottom ash, after heat exchanger ash, and deposited ash, respectively.

< 8 >

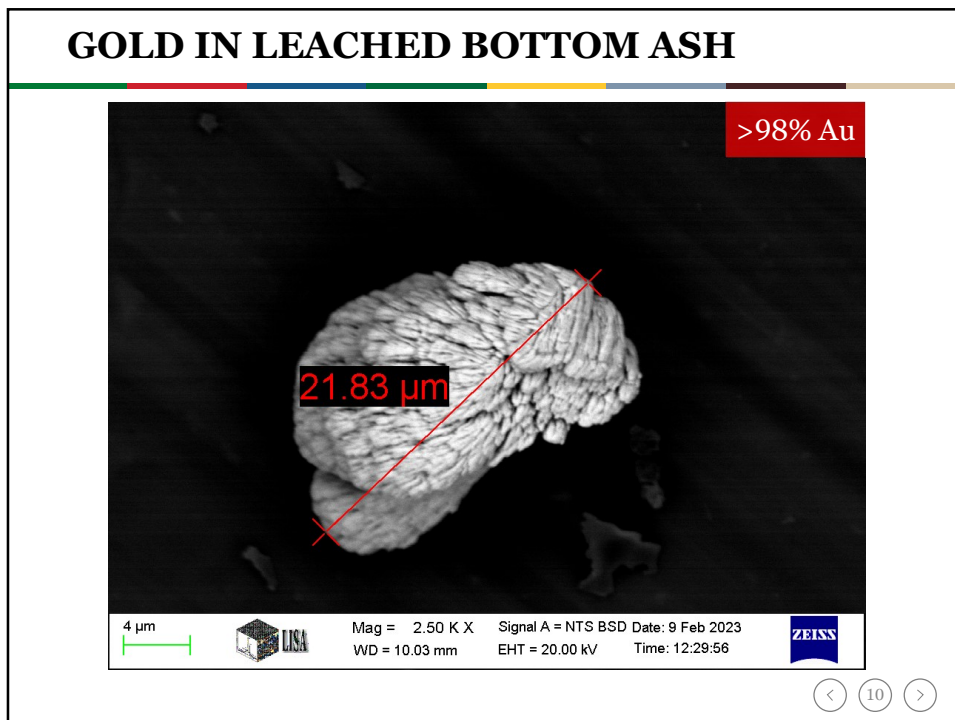
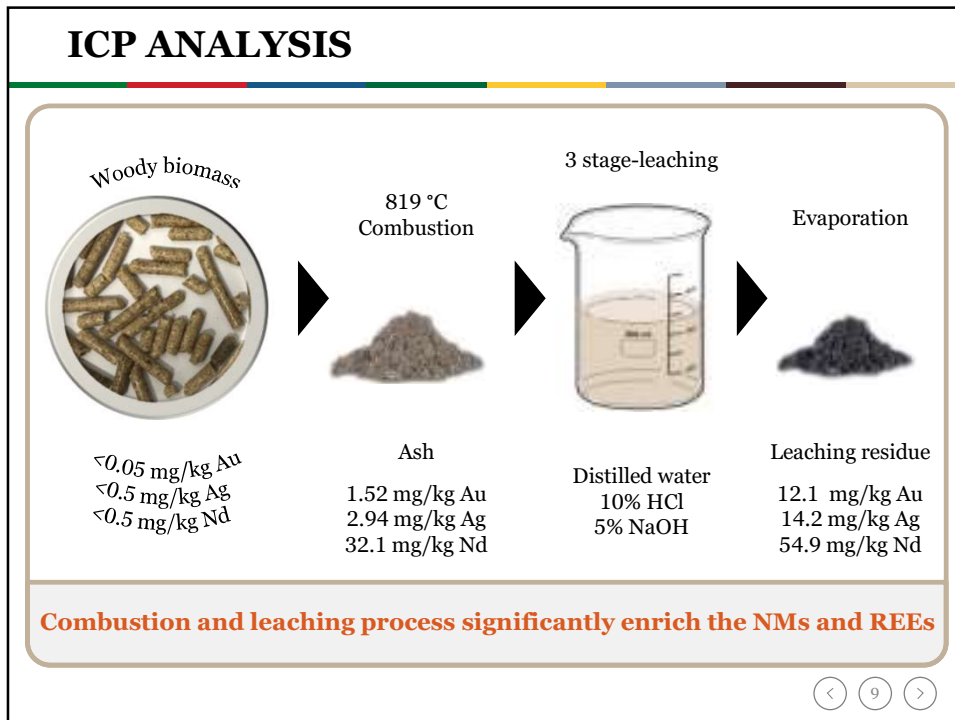

### GOLD IN LEACHED BOTTOM ASH

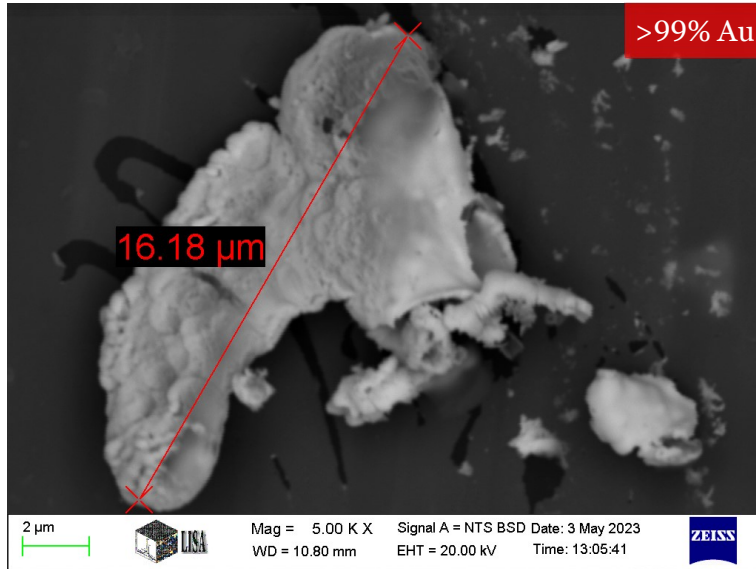

< 11 >

### GOLD IN AFTER HEAT EXCHANGER ASH

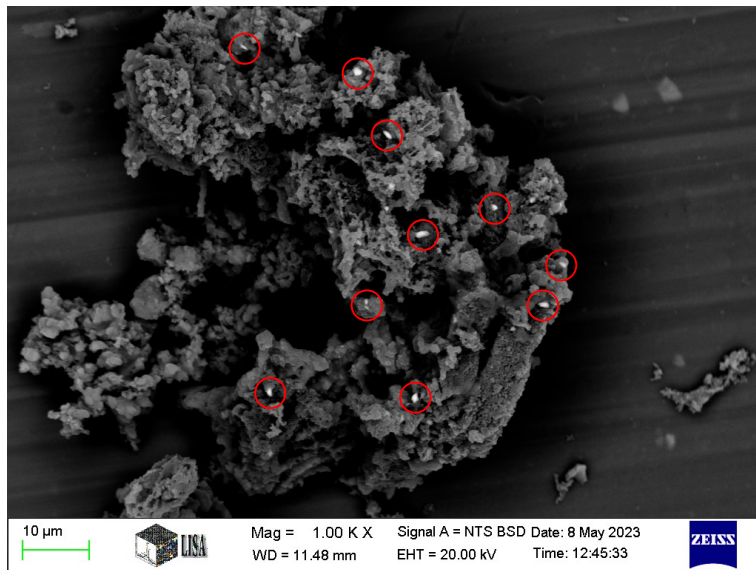

< 12 >

## GOLD IN DEPOSITED ASH

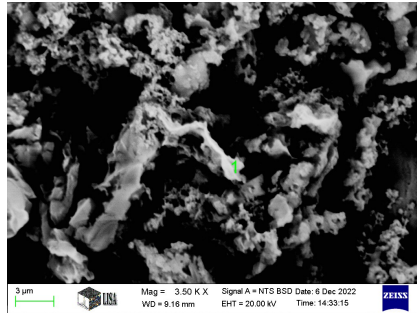

Ele.	Concentration (wt%)
C	7.4
O	20.64
Al	9.38
Au	35.42
S	4.49
K	21.63
Zn	1.04

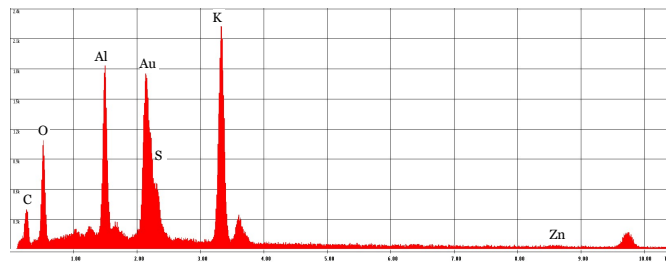

< 13 >

## GOLD IN FLY ASH

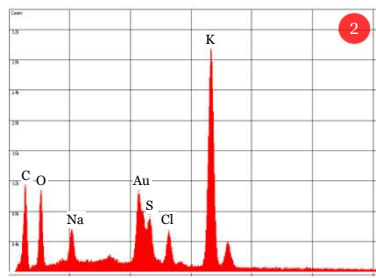

2

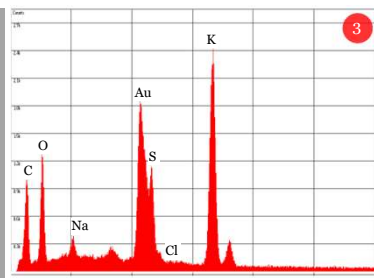

3

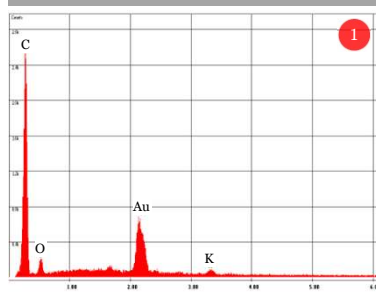

1

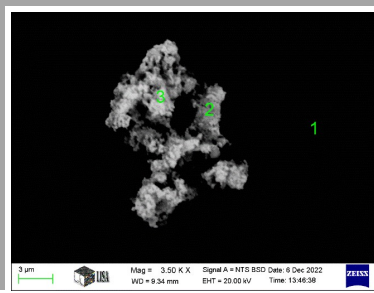

< 14 >

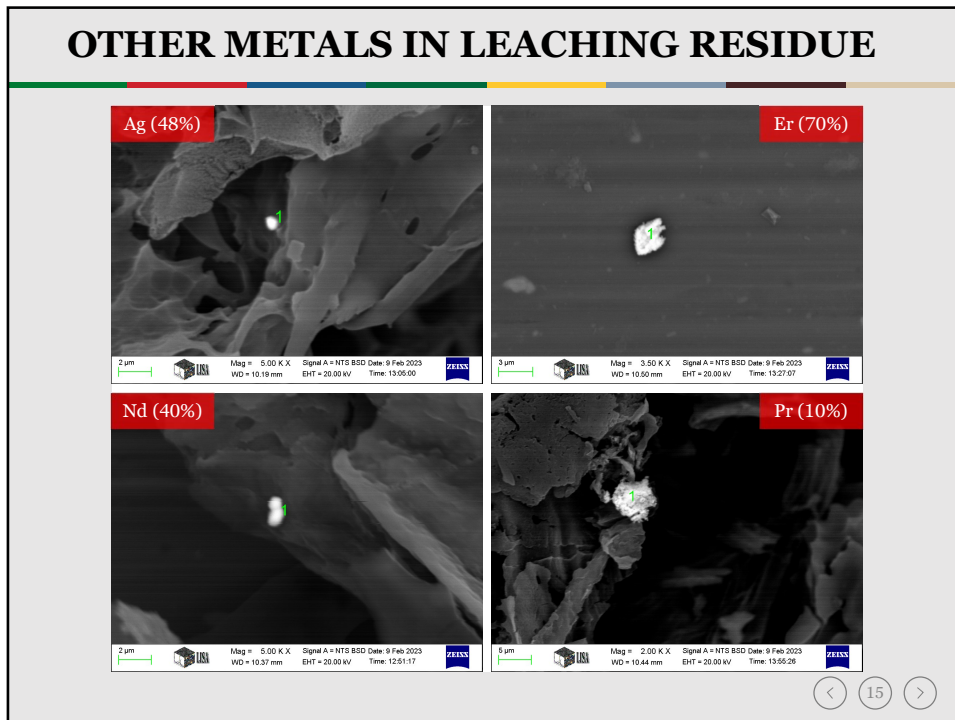

**Conclusion**

Combustion and leaching processes can significantly enrich the NMs and REEs concentration from the woody biomass into the leaching residual. Gold was present as pure particles in bottom ash and heat exchanger ash, but as compounds in fly and deposited ash. The formations of other valuable metals exhibited various patterns.

---

**Conclusion & Outlook**

---

**Outlook**

Noble metals and rare earth elements will be subsequently extracted and recovered from the leaching residues. The combustion technique and somehow the overall concept of phytoextraction-enrichment-extraction can be applied to other material inputs of contaminated biomass coming from different brownfields.

16



**MISKOLCI**  
EGYETEM  
UNIVERSITY OF MISKOLC

**THANK YOU**

 **Truong Phi Dinh**

 [truong.dinh@uni-miskolc.hu](mailto:truong.dinh@uni-miskolc.hu)

 **Institute of Energy, Ceramics  
and Polymer Technology**

 [www.energy.uni-miskolc.hu](http://www.energy.uni-miskolc.hu)



# Investigation of carbon dioxide conversion via microwave plasma and its characterization

Balazs Peter KISS, George KAPTAY, Zsolt DOBO



EnergyWaterFoodClimateNexus 27.08.2025

Miskolc, Hungary

## Contents



### What are the key parameters from the literature?

CCSU and Power to X

Main differences between studies according to CO<sub>2</sub> conversion and energy efficiency



### Experimental setup and used methods

Materials and methods for plasma characterization and pure CO<sub>2</sub> conversion and energy efficiency calculation



### Results and discussion

Characteristic curve form OES data & Pure CO<sub>2</sub> conversion

How are these results connecting

EnergyWaterFoodClimateNexus 2025



# Introduction



## Motivation

Give a possible solution for problem caused by  $\text{CO}_2$



## CCSU and Power to X

I will focus on utilization  
Using renewable electricity to make value added products  
Non-thermal plasma



## Literature

Typical catalyst-free conversion: 30–35%  
Typical energy efficiency: 5–15%  
You can't maximize both at once

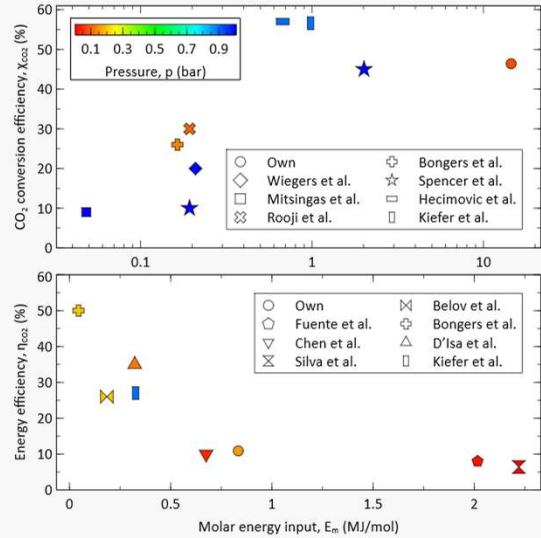

EnergyWaterFoodClimateNexus 2025

# Experimental setup

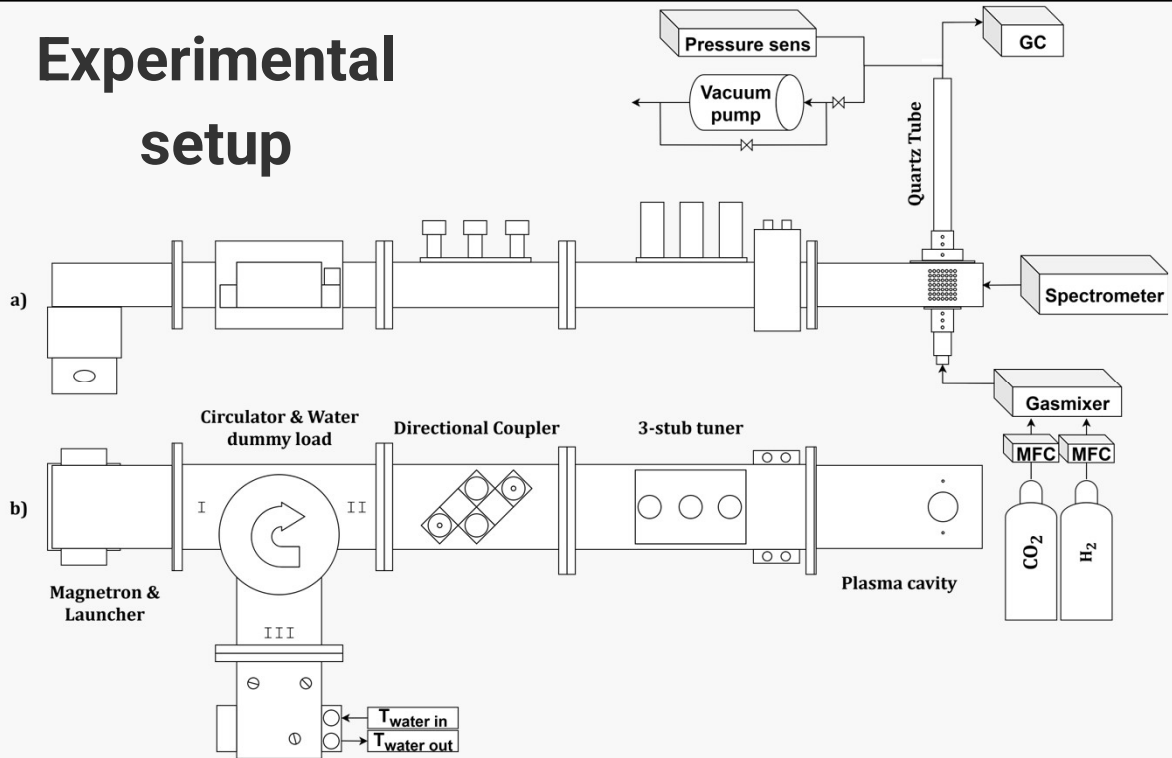

## Methodology – Primary results

**OH radical spectral region – Plasma gas temperature,  $T_g$**

Method: Boltzmann plot.

The obtained value is the rotational temperature, which according to the literature correlates with the gas temperature

**$H_\alpha$  spectral region – Electron number density,  $n_e$**

The Stark broadening of the line spectrum correlates with the electron concentration

**Atomic oxygen (O) spectral region – Electron temperature,  $T_e$**

Method: Boltzmann plot.

The obtained value is the excitation energy, which according to the literature provides a lower estimate and correlates with the electron temperature

**Primary results for plasma characterization**

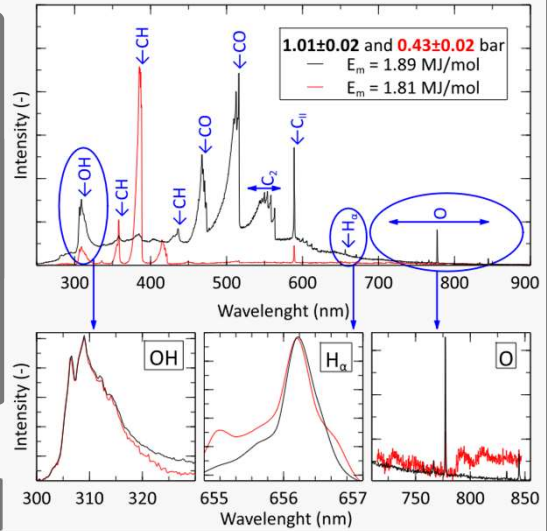

EnergyWaterFoodClimateNexus 2025

## Methodology – Characteristic curve

$$n_{np} = \frac{p}{k_B \cdot T_g} \quad \text{Neutral particle density}$$

$$v = \sqrt{\frac{8 \cdot T_e \cdot k_B}{\pi \cdot m_e}} \quad \text{Electron velocity}$$

$$v_{e-np} = n_{np} \cdot v \cdot \sigma_{tot} \quad \text{Collision frequency}$$

$$\mathcal{P}_{coll} = \frac{P_\omega}{V \cdot E^2} = \frac{e^2}{m_e} \cdot n_e \cdot \frac{v_{e-np}/\omega}{1 + (v_{e-np}/\omega)^2} \quad \text{Specific power absorption}$$

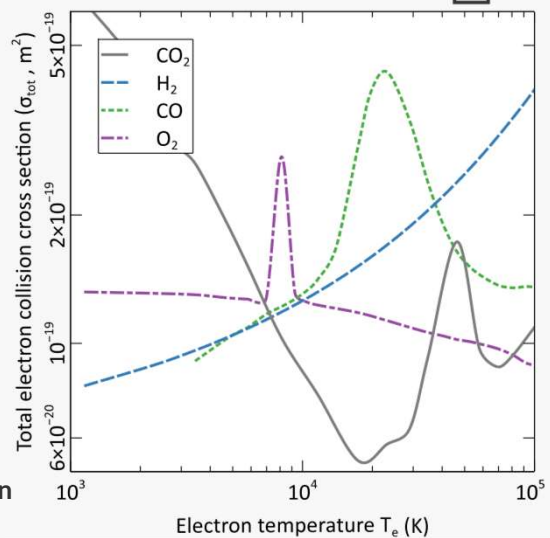

EnergyWaterFoodClimateNexus 2025

## Methodology – Conversion & efficiency

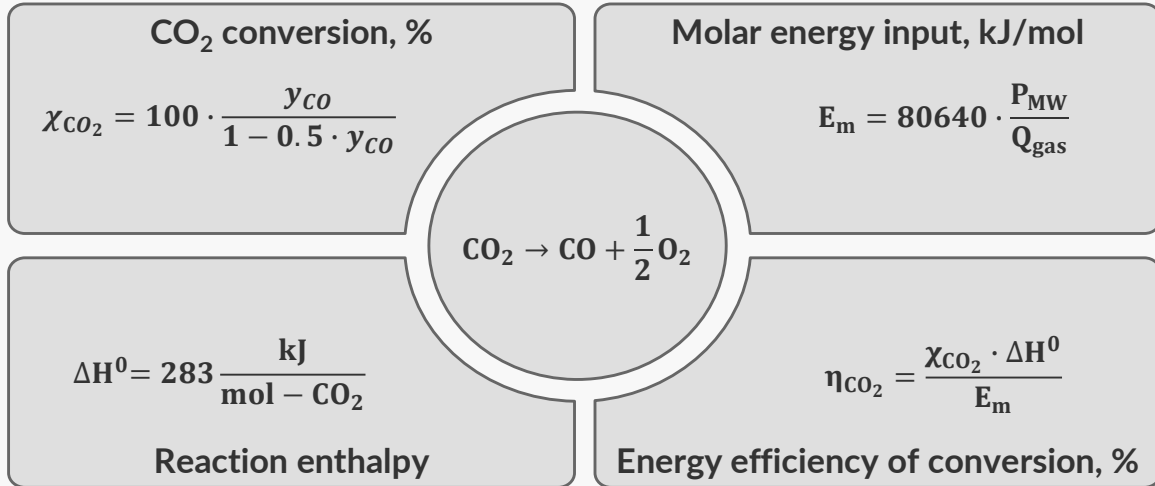

EnergyWaterFoodClimateNexus 2025

## Results – Plasma characterization



	Gas temperature	Electron density	Electron temperature
Atmospheric pressure	2.84-2.97 kK	1.8-2.06·10 <sup>22</sup> m <sup>-3</sup>	13.7-16.6 kK
Reduced pressure	2.37-3.18 kK	1.8-2.47·10 <sup>22</sup> m <sup>-3</sup>	6.35-15 kK

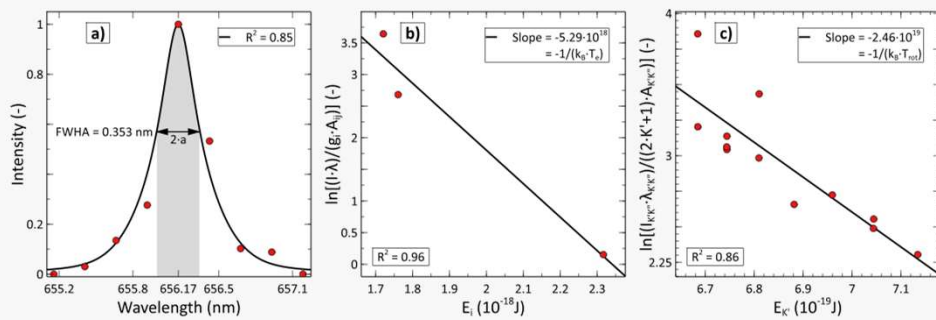

EnergyWaterFoodClimateNexus 2025

## Results – Characteristic curve

$\mathcal{P}_{\text{coll}}^{\text{max}} @ v_{e-np}/\omega = 1$   
 $\eta_{\text{coupling}} \equiv 100 \cdot \frac{\mathcal{P}_{\text{coll}}}{\mathcal{P}_{\text{coll}}^{\text{max}}}$

$\eta_{\text{coupling}}$ :

$P_{\text{optimal@2.45 GHz}} \approx 0.1 \text{ bar}$   
 $f_{\text{optimal@1.01 bar}} \approx 20 \text{ GHz}$

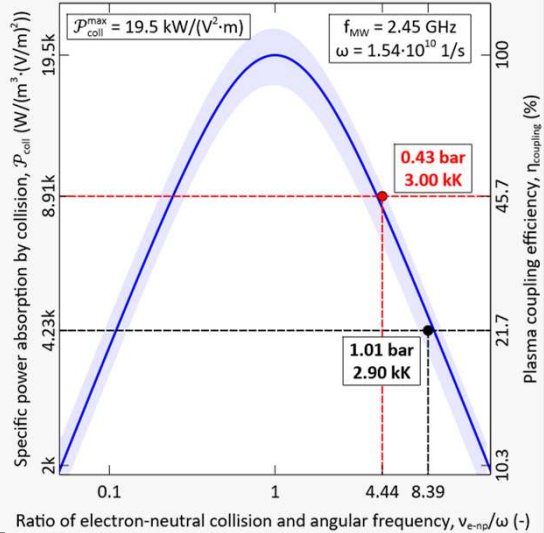

EnergyWaterFoodClimateNexus 2025

## Results – Conversion & efficiency

- Reducing  $p$  leads to higher  $\chi$  and  $\eta$
- Increasing  $E_m$  lowers  $\eta$  and after a point no longer increases  $\chi$   
Plasma  $\rightarrow$  thermodynamic equilibrium
- Optimum  $\eta \cdot \chi = \text{MAX}$   
30 NL/h:  $\eta = 4.5\%$ ,  $\chi = 40\%$
- Observed extremes  
 $\eta = 10.9\%$ ,  $\chi = 46.4\%$

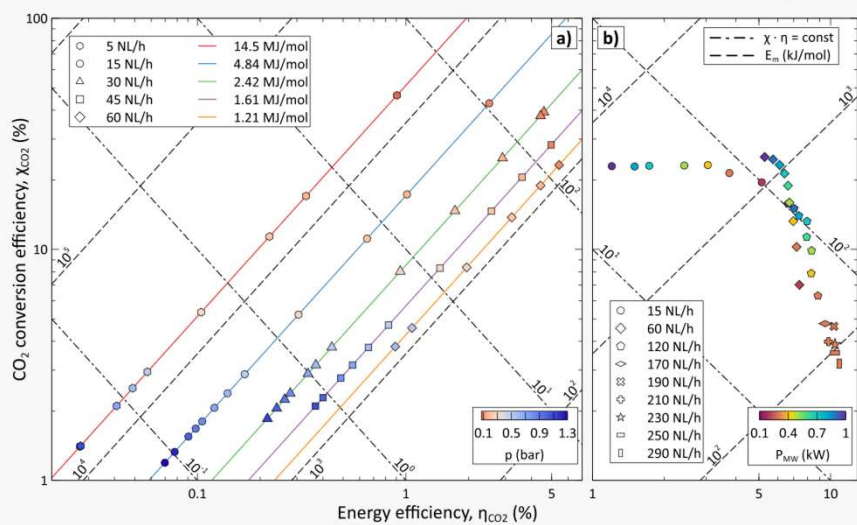

EnergyWaterFoodClimateNexus 2025

## Conclusion – Key finding

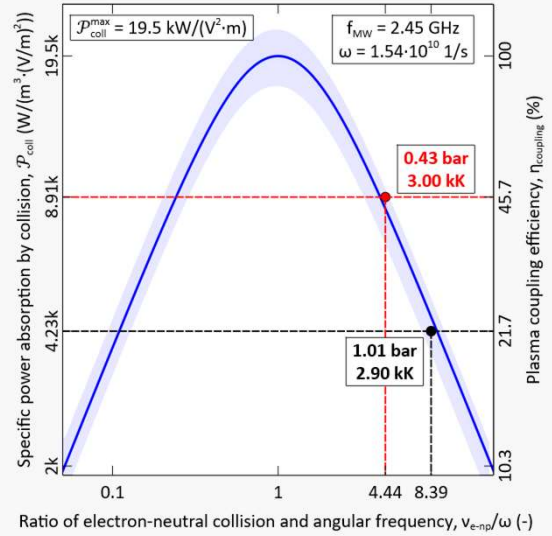
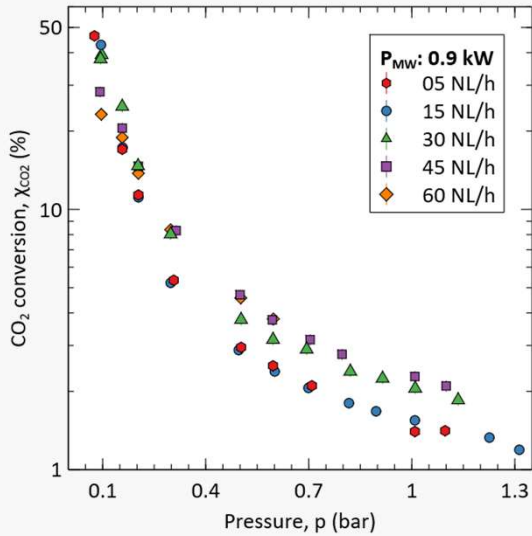

EnergyWaterFoodClimateNexus 2025

## Recently published papers - Outlook

- B. P. Kiss, C. E. Tóth, I. Slezsák, G. Kaptay, Z. Dobó, *Carbon dioxide conversion and characterization of microwave-induced plasma*. *Frontiers of Chemical Science and Engineering*. (2025).
  - You may gain deeper insight into today's topic
- B. P. Kiss, G. Kaptay, Z. Dobó, *Investigation of microwave-induced nitrogen-oxygen plasma for nitrogen fixation*. *International Journal of Plasma Environmental Science and Technology*. (2025).
  - Sustainable, plasma-assisted nitrogen fixation
- B. P. Kiss, Z. Dobó, G. Kaptay, *Green Reverse Water Gas Shift Reaction Achieved by Microwave-Induced Plasma*. *Green Chemistry Letters And Reviews*. (2025). (accepted)
  - Experimental and theoretical investigations about plasma based RWGS for syngas production

EnergyWaterFoodClimateNexus 2025

# Thanks!

Do you have any questions?  
balazs.peter.kiss@uni-miskolc.hu

SUPPORTED BY THE UNIVERSITY RESEARCH SCHOLARSHIP PROGRAM OF THE MINISTRY FOR CULTURE AND INNOVATION FROM THE SOURCE OF THE NATIONAL RESEARCH, DEVELOPMENT AND INNOVATION FUND.

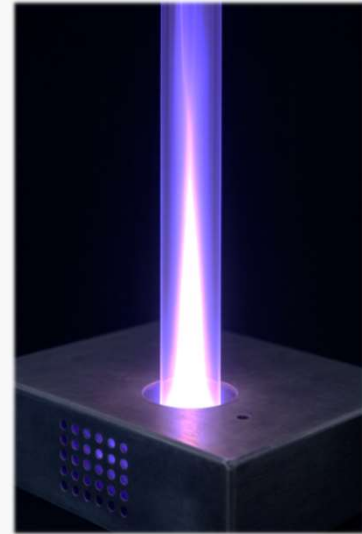

EnergyWaterFoodClimateNexus 27.08.2025

Miskolc, Hungary

## Results – Characteristic curve

$\mathcal{P}_{\text{coll}}^{\text{max}} @ v_{e-np}/\omega = 1$   
 $\eta_{\text{coupling}} \equiv 100 \cdot \frac{\mathcal{P}_{\text{coll}}}{\mathcal{P}_{\text{coll}}^{\text{max}}}$

$\eta_{\text{coupling}}$ :

$p_{\text{optimal@2.45 GHz}} \approx 0.1 \text{ bar}$   
 $f_{\text{optimal@1.01 bar}} \approx 20 \text{ GHz}$

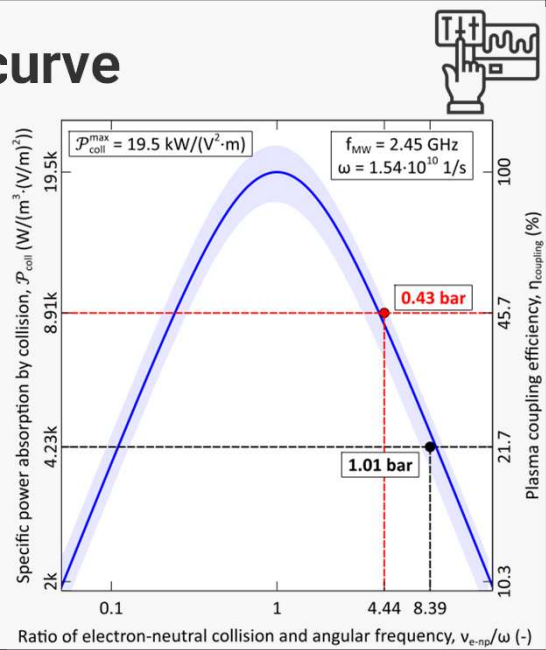

EnergyWaterFoodClimateNexus 2025

## Conclusion – Key findings

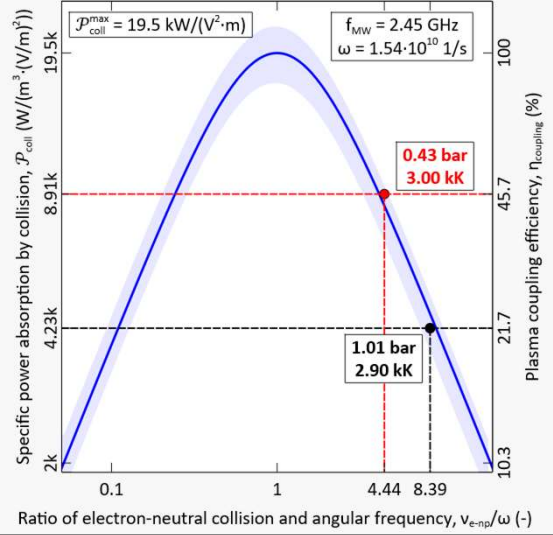
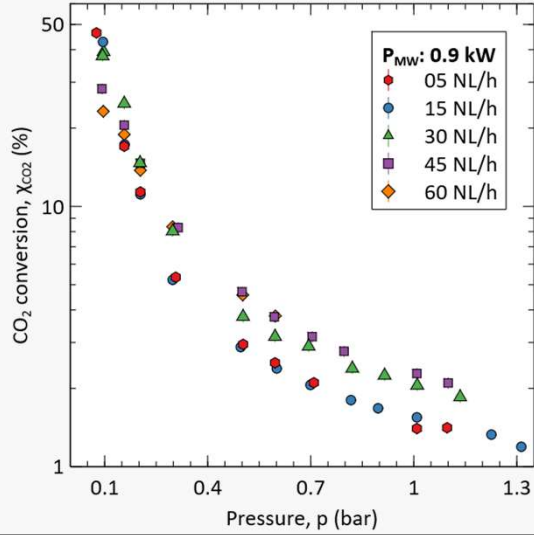

EnergyWaterFoodClimateNexus 2025

WHAT WE WANT IS  
**POSSIBLE**



ENERGY WATER FOOD CLIMATE  
**NEXUS**<sup>®</sup>  
INTERNATIONAL SUMMIT

## HYDROGEN UTILISATION POTENTIAL AND EXPERIENCE IN CONVENTIONAL HEAT ENGINES

**K. Lukács., E. Lévai, Á. Bereczky**

Energy, Water, Food and Climate Nexus International Summit,  
August 26-28, 2025 Miskolc



### HYDROGEN-RELATED VISIONS

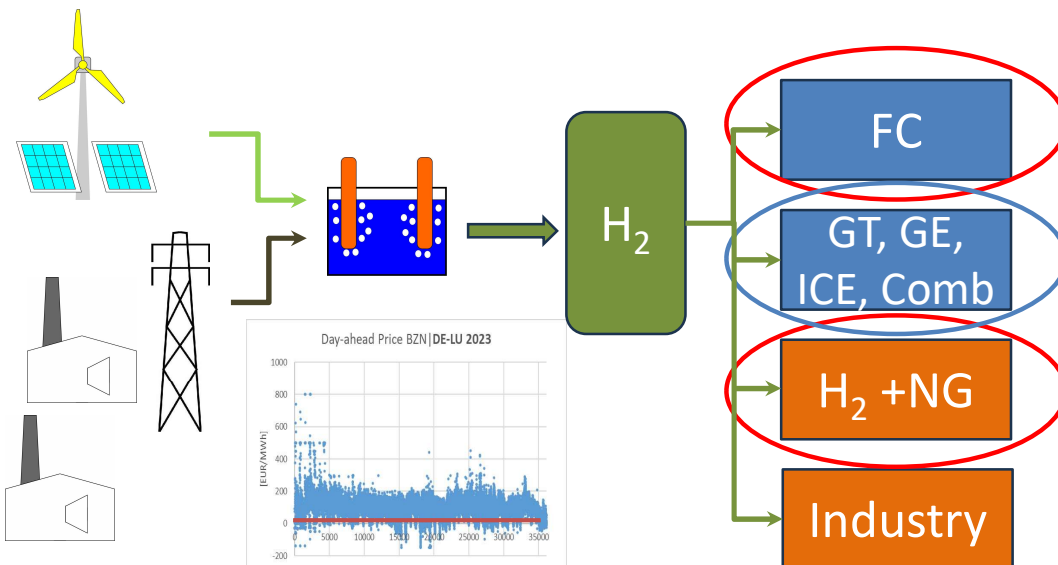

## ELECTRICITY PRICES IN 2023

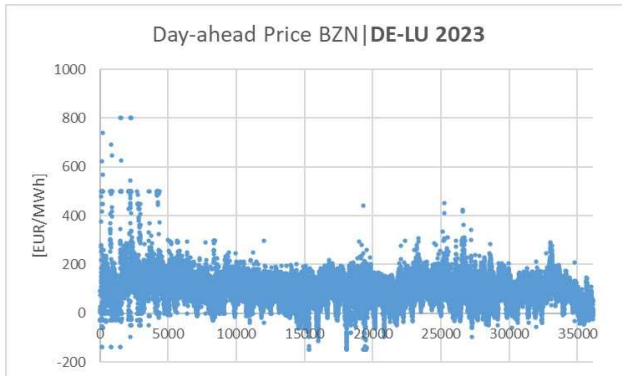

### Installed capacity in Hungary (2025):

Solar: 6,3 GW  
Nuclear: 1,9 GW  
Gas: 2,97 GW

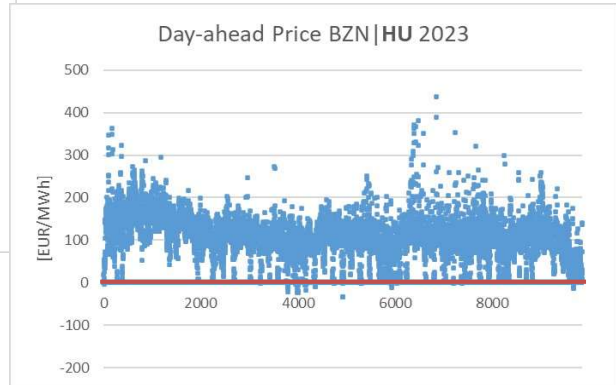

- Day-ahead energy prices in DE-LU and HU countries in 2023 [2]
- MAVIR, (<http://mavir.hu/web/mavir/eromuvi-termeles-forrasok-megoszlasa-szerint-netto-uzemiranyitasi-meresek-alapjan> )
- ENTSO-E Transparency Platform ( <https://transparency.entsoe.eu/> )



DEPARTMENT OF  
ENERGY ENGINEERING

## CARBON INTENSITY OF HUNGARY 20/08/2025

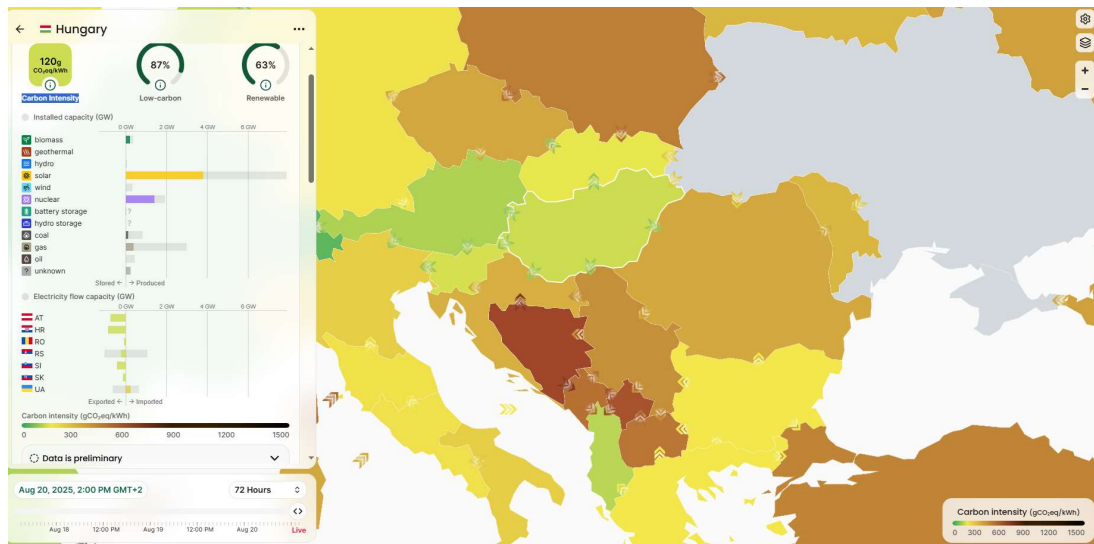

DEPARTMENT OF  
ENERGY ENGINEERING

<https://app.electricitymaps.com/zone/HU/72h/hourly?solar=false&remote=true&wind=false>

## COMPARISON OF ENERGY STORAGE METHODS

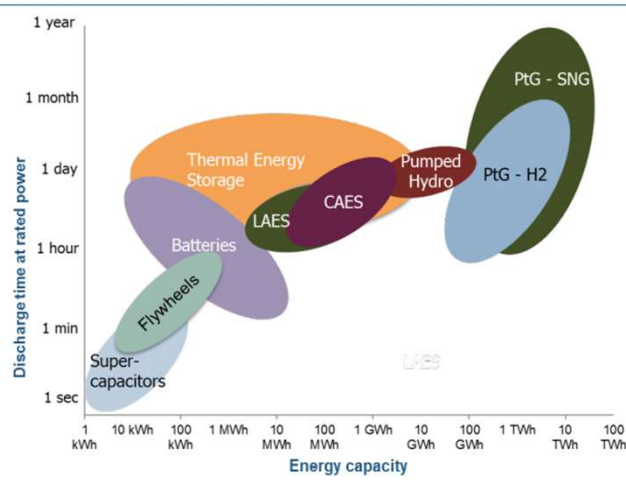

Comparison between Power-to-Gas (P2G) technology and other energy storage technologies. Liquid Air energy Storage (LAES), Compressed Air Energy Storage (CAES), Synthetic Natural Gas (SNG). Source (PWC) [<https://www.worldenergy.org/assets/downloads/Resources-E-storage-report-2016.02.04.pdf>]



## HYDROGEN-RELATED VISIONS from AUSTRALIA

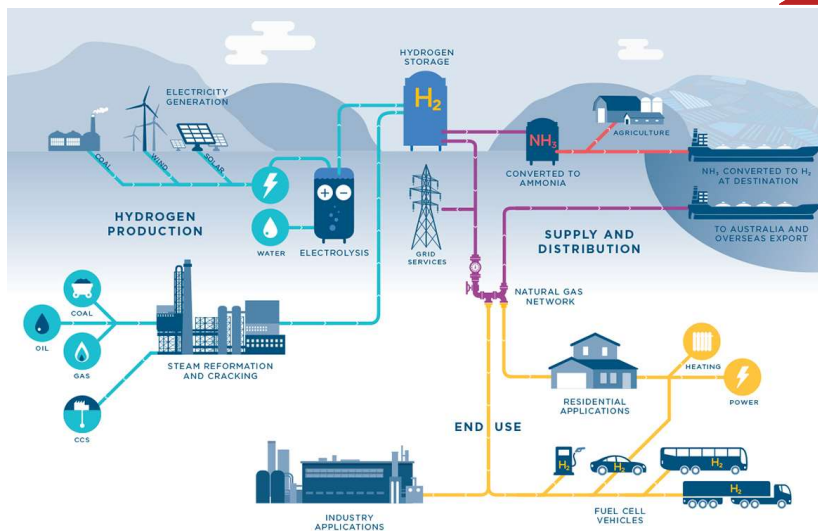

<https://www.herbertsmithfreehills.com/insights/2019-09/a-national-hydrogen-strategy-shaping-possibilities-for-australias-hydrogen-economy>



## P2G METHODS

- 1)  $H_2O + E \rightarrow H_2 + O_2$
- 2)  $4H_2 + CO_2 \rightarrow$  Methanization  $\rightarrow CH_4 + 2 H_2O$   
– Biomethanation or Sabatier reaction (T)
- 3) Synthetic (or E) Fuels
- 4) Fischer-Tropsch Process (T)  
– pl.:  $(2n + 1) H_2 + n CO \rightarrow C_n H_{2n+2} + n H_2O$

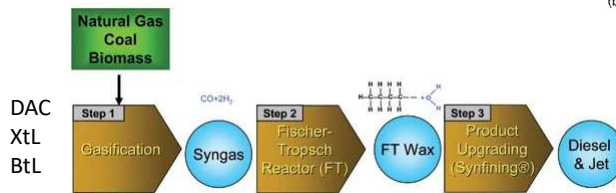
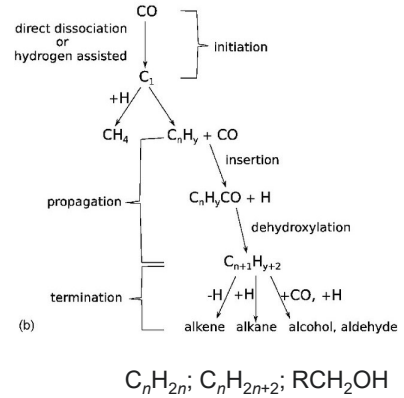

<https://www.azocleantech.com/article.aspx?ArticleID=385>

van Santen, R. A. and Markvoort, A. J. and Filot, I. A. W. and Ghouri, M. M. and Hensen, E. J. M.: Mechanism and microkinetics of the Fischer-Tropsch reaction, Phys. Chem. Chem. Phys., 2013, 15(40), pp 17038-17063, doi=10.1039/C3CP52506F,

## HUNGARIAN NATURAL GAS SYSTEM



### Key indicators (2025)

Number of settlements supplied with piped gas: 2,876 (91.2%),  
Number of households consuming piped gas: 3,241,149 (70.4%),  
Length of gas pipeline network: 85,703 km,  
Annual piped gas consumption per household consumer: 827.0 m<sup>3</sup>

[https://mindentafoldgazrol.hu/uploads/FGSZ\\_vezetekrendszer\\_20160211.jpg](https://mindentafoldgazrol.hu/uploads/FGSZ_vezetekrendszer_20160211.jpg)

[https://www.ksh.hu/stadat\\_files/kor/hu/kor0043.html](https://www.ksh.hu/stadat_files/kor/hu/kor0043.html)



## BIOMETHANE INJECTION



The map displays historical data of the Hungarian high-pressure natural gas transmission system's Exit points, which aims to assist interested parties considering biomethane injection into the gas network

<https://fgsz.hu/en>



## LEHETŐSÉGEK

- The blending of hydrogen into the network is permitted in several countries [5]: 10% in Germany under certain conditions, 6% in France, 4% in Austria, and 1% in Finland.
- According to one study, hydrogen can be fed into the gas network at a rate of 5-10% in the near future without the need for significant modifications to the transmission infrastructure and end-user equipment.
- Towards the end of the decade, this could increase to 15-20% once the necessary changes have been made to the infrastructure and consumer equipment [6].

Limitations on Hydrogen Concentration in National Gas Grid

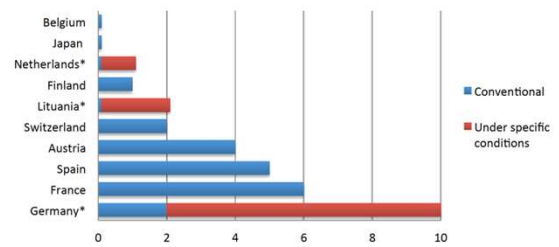

## COMPARISON OF THE COMBUSTION PARAMETERS OF HYDROGEN AND METHANE

Parameter	Unit	Hydrogen	Methane	Change (H <sub>2</sub> /CH <sub>4</sub> )
Molecular weight	kg/kmol	2,0159	16,043	12,57%
Specific gas constant	J/(kgK)	4124,47	518,26	795,83%
Real gas factor at normal conditions	-	1,0006	0,9976	100,30%
Density at normal conditions	kg/m <sup>3</sup>	0,08989	0,7175	12,53%
Relative density at normal conditions	-	0,0695	0,555	17,57%
Theoretical combustion air requirement [V/V (m <sup>3</sup> /m <sup>3</sup> )]	-	2,39 (34,3)	9,7 (17,2)	24,64%
HHV	MJ/m <sup>3</sup>	12,745	39,831	32,00%
LHV	MJ/m <sup>3</sup>	10,782	35,894	30,04%
	MJ/kg	119,947	50,026	239,77%
	MJ/m <sup>3</sup>	40,892	48,184	84,87%
Lower Wobbe index	kWh/m <sup>3</sup>	11,359	13,384	84,87%
Ignition temperature	°C	530	645	82,17%
Ignition limits in air at 20°C (λ)	-	9,83-0,14	1,99-0,59	-
Ignition limits in air at 20°C	V/V%	4,0-77,0	4,4-16,5	-
Maximum laminar flame propagation speed in air	cm/s	346	43	804,65%
Specific heat at constant pressure	kJ/(kgK)	14,200	2,156	658,63%
Specific heat at constant volume	kJ/(kgK)	10,076	1,638	615,14%
Adiabatic exponent	-	1,409	1,316	107,07%
Kinematic viscosity	m <sup>2</sup> /s	106·10 <sup>-6</sup>	16,7·10 <sup>-6</sup>	-
Methane number	-	0	100	0,00%



DEPARTMENT OF ENERGY ENGINEERING

## ADIABATIC FLAME TEMPERATURE

The adiabatic flame temperature is of great importance for the combustion process and the chemical reactions that take place, and is also crucial in terms of emissions (e.g. NO<sub>x</sub>).

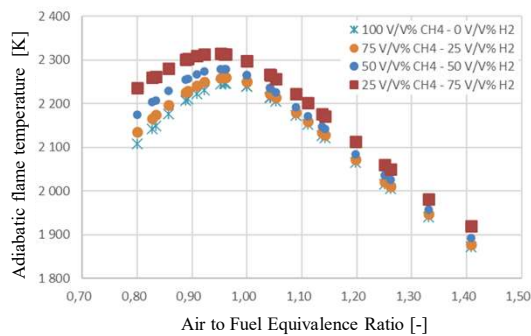

Adiabatic flame temperature as a function of excess air for different H<sub>2</sub> mixtures (GRI 3.0 mechanism, T<sub>0</sub>= 323 K, P<sub>0</sub>= 0.1 Mpa)



DEPARTMENT OF ENERGY ENGINEERING

## LAMINAR FLAME PROPAGATION VELOCITY

The laminar flame propagation velocity is a parameter that characterizes the speed of combustion. The laminar flame speed increases continuously with the addition of hydrogen. The increase is faster than linear

For CH<sub>4</sub>, it is between 0.9 and 1 with maximum H<sub>2</sub> addition, the maximum shifts to the rich range

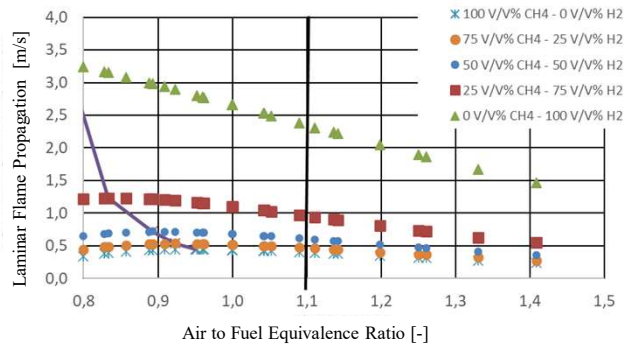

Laminar flame propagation velocity as a function of different H<sub>2</sub> mixing ratios (GRI 3.0 mechanism, T<sub>0</sub>= 323 K, P<sub>0</sub>= 0.1 Mpa)



DEPARTMENT OF  
ENERGY ENGINEERING

## LOWER AND UPPER INFLAMMATION LIMITS

Parameter	Unit	Hydrogen	Methane
Ignition limits in air at 20°C ( $\lambda$ )	-	9,83-0,14	1,99-0,59
Ignition limits in air at 20°C	%	4,0-77,0	4,4-16,5

Fuels can be ignited between the lower and upper flammability limits, and mixtures outside these limits cannot be ignited.

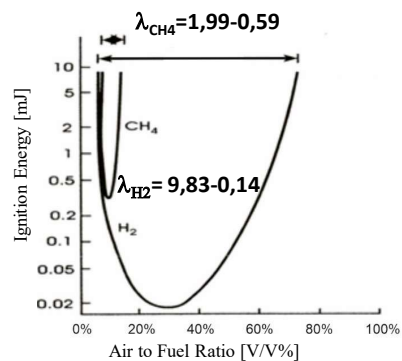

DEPARTMENT OF  
ENERGY ENGINEERING

# 1. / INJECTOR BURNERS – DOMESTICAL BURNERS

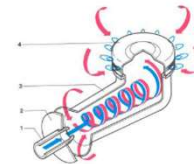
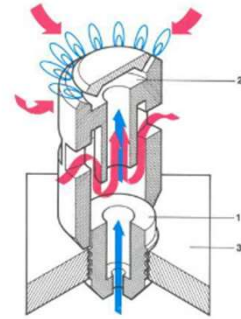
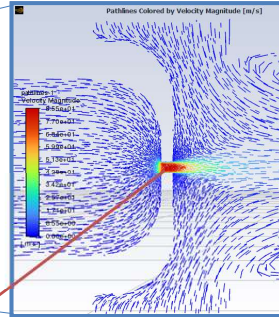

$$\dot{V}_{FUEL} = \alpha \frac{D^2 \pi}{4} \sqrt{\frac{2(p_0 - p_1)}{\rho_{FUEL}}}$$



Lévai, Emese ☒ ; Bereczky, Ákos: Effect of hydrogen mixing on the flame geometry of natural gas-powered equipment, POLLACK PERIODICA: AN INTERNATIONAL JOURNAL FOR ENGINEERING AND INFORMATION SCIENCES 20 : 2 pp. 119-123. , 5 p. (2025)

# THE EFFECTS OF HYDROGEN BLENDING - THEORY

Switching from natural gas to 23 V/V% H<sub>2</sub> – CH<sub>4</sub> mixture

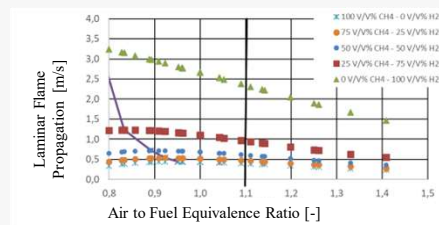
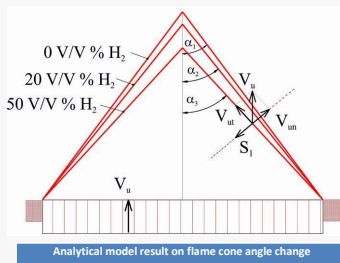

Lévai, Emese ☒ ; Bereczky, Ákos: Effect of hydrogen mixing on the flame geometry of natural gas-powered equipment, POLLACK PERIODICA: AN INTERNATIONAL JOURNAL FOR ENGINEERING AND INFORMATION SCIENCES 20 : 2 pp. 119-123. , 5 p. (2025)

## THE EFFECTS OF HYDROGEN BLENDING IN INJECTOR BURNERS - THEORY

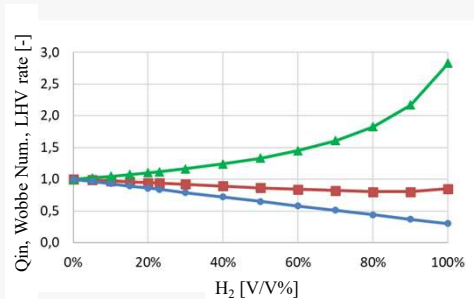

$$\dot{V}_{CH_4+H_2} / \dot{V}_{CH_4} = \alpha \frac{D^2 \pi}{4} \sqrt{\frac{2(p_0 - p_1)}{\rho_{CH_4+H_2}}} / \alpha \frac{D^2 \pi}{4} \sqrt{\frac{2(p_0 - p_1)}{\rho_{CH_4}}}$$

$$\dot{Q}_{inCH_4+H_2} / \dot{Q}_{inCH_4} = Wobbe_{CH_4+H_2} / Wobbe_{CH_4}$$

$$LHV_{CH_4+H_2} / LHV_{CH_4}$$

Numerous parameters must be measured and/or modelled, e.g.:

- The extent to which losses (flow and heating) hinder the theoretical volume flow increase;
- How the primary mixing with air changes in the injector;
- How this affects the flame pattern (re-ignition);
- How the efficiency of the equipment and the emission of harmful substances change;



DEPARTMENT OF ENERGY ENGINEERING

## THE EFFECTS OF HYDROGEN BLENDING IN INJECTOR BURNERS – TEST RESULTS

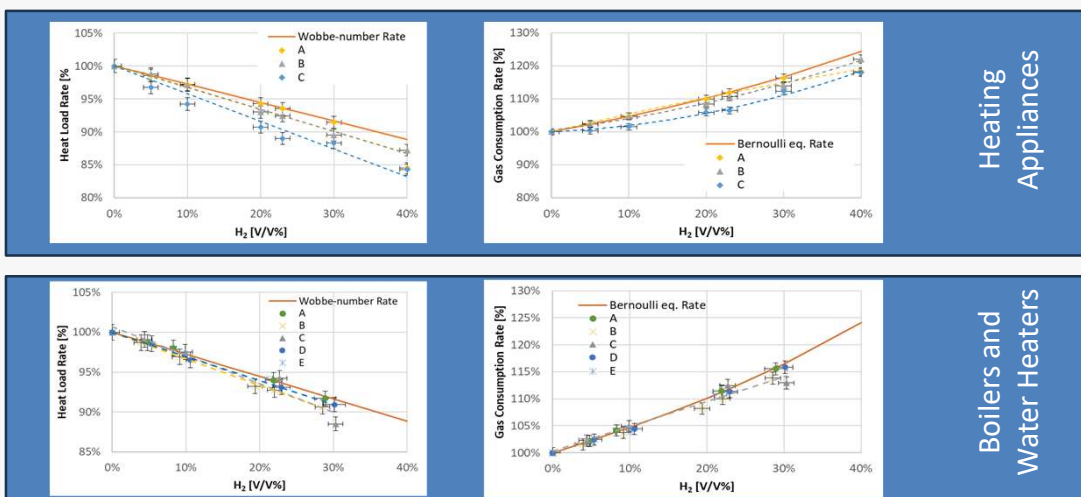

Léval, Emese ; Dobi-Szakál, Gyöngy ; Szalontai, Péter ; Lukács, Kristóf ; Bereczky, Ákos: Üzemelő kazánok és vízmelegítők vizsgálata hidrogéntartalmú földgázzal, MAGYAR ENERGETIKA 31 : 3 pp. 2-13. , 12 p. (2024)  
 Szalontai Péter, Dr. Bereczky Ákos: Üzemelő gázkészülékek vizsgálata hidrogén tartalmú földgázzal, 30. DUNAGÁZ Konferencia és Kiállítás, Esztergom, 2024.06.04.- 05.



DEPARTMENT OF ENERGY ENGINEERING

## THE EFFECTS OF HYDROGEN BLENDING IN INJECTOR BURNERS – TEST RESULTS

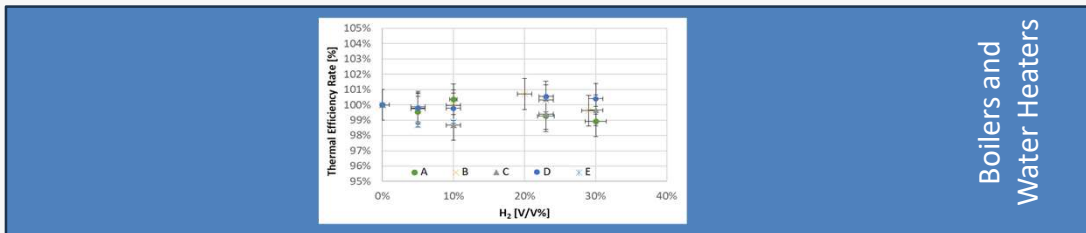
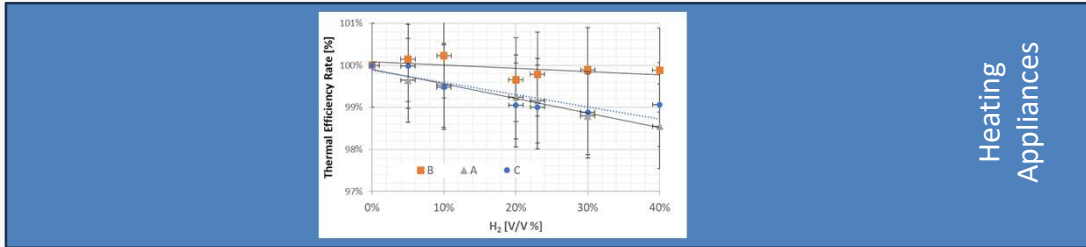

DEPARTMENT OF ENERGY ENGINEERING

Lévai, Emese ; Dobi-Szakál, Gyöngy ; Szalontai, Péter ; Lukács, Kristóf ; Bereczky, Ákos: Üzemelő kazánok és vízmelegítők vizsgálata hidrogéntartalmú földgázzal, MAGYAR ENERGETIKA 31 : 3 pp. 2-13. , 12 p. (2024)  
 Szalontai Péter, Dr. Bereczky Ákos: Üzemelő gázkészülékek vizsgálata hidrogén tartalmú földgázzal, 30. DUNAGÁZ Konferencia és Kiállítás, Esztergom, 2024.06.04.- 05.

## THE EFFECTS OF HYDROGEN BLENDING IN INJECTOR BURNERS – TEST RESULTS

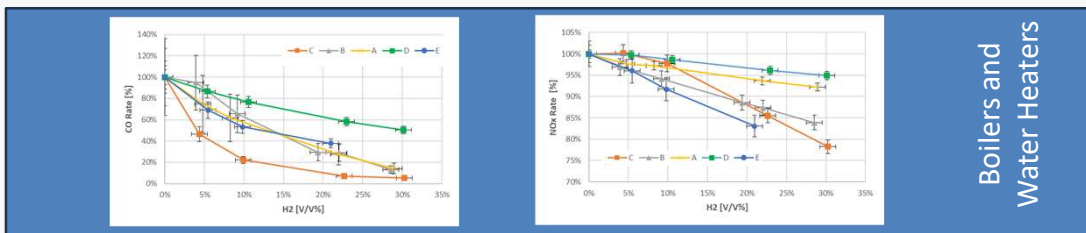
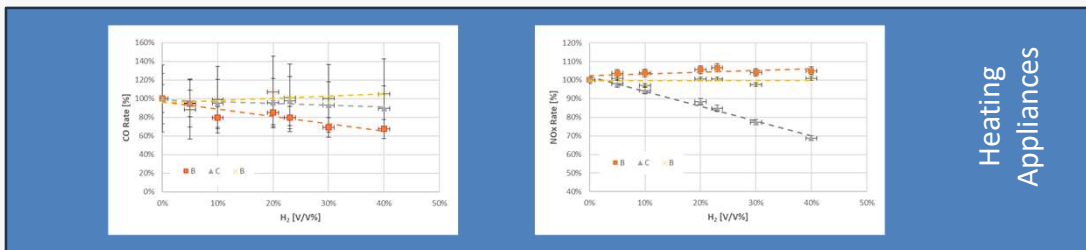

DEPARTMENT OF ENERGY ENGINEERING

Lévai, Emese ; Dobi-Szakál, Gyöngy ; Szalontai, Péter ; Lukács, Kristóf ; Bereczky, Ákos: Üzemelő kazánok és vízmelegítők vizsgálata hidrogéntartalmú földgázzal, MAGYAR ENERGETIKA 31 : 3 pp. 2-13. , 12 p. (2024)  
 Szalontai Péter, Dr. Bereczky Ákos: Üzemelő gázkészülékek vizsgálata hidrogén tartalmú földgázzal, 30. DUNAGÁZ Konferencia és Kiállítás, Esztergom, 2024.06.04.- 05.

## EFFECTS OF HYDROGEN INTENSIFICATION - HEATING APPLIANCE

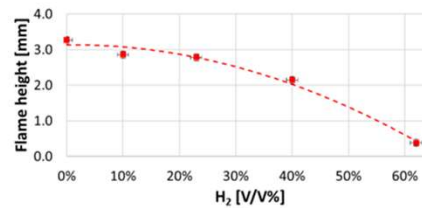
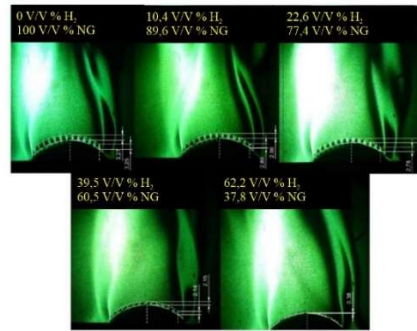
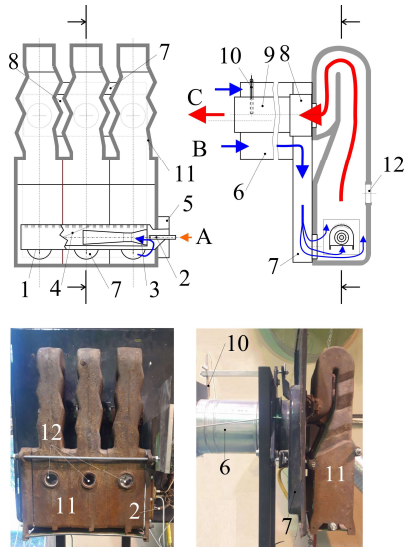

DEPARTMENT OF ENERGY ENGINEERING

Lévai, Emese; Bereczky, Ákos: Analysis of operational parameters and emissions in a domestic natural gas heating appliance with hydrogen blending, INTERNATIONAL JOURNAL OF HYDROGEN ENERGY 97 pp. 950-958., 9 p. (2025)

## EFFECTS OF HYDROGEN INTENSIFICATION - CONVECTORS

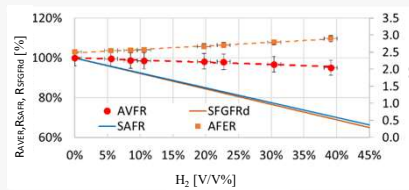
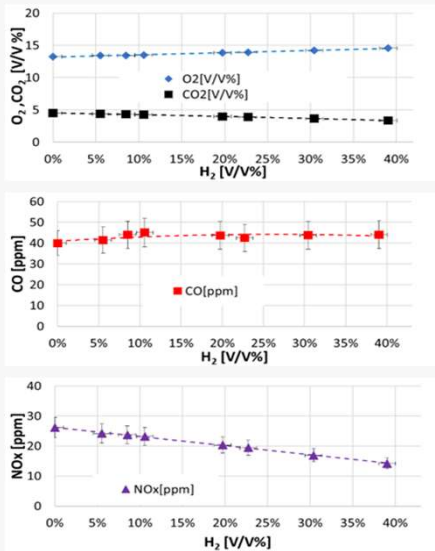

Relative air volume flow rate (RAVFR), stoichiometric air-fuel ratio (SAFR), dry stoichiometric flue gas-fuel ratio (RSFGFRd) and air-fuel equivalence ratio (AFER,  $\lambda$ ) as a function of hydrogen mixing.



DEPARTMENT OF ENERGY ENGINEERING

Lévai, Emese; Bereczky, Ákos: Analysis of operational parameters and emissions in a domestic natural gas heating appliance with hydrogen blending, INTERNATIONAL JOURNAL OF HYDROGEN ENERGY 97 pp. 950-958., 9 p. (2025)

## SUMMARY

- What operational changes should be expected in the case of hydrogen natural gas supply?  
According to theoretical considerations, the gas volume flow increases, but its extent depends on the design of the equipment and the losses that occur. Thus, the heat input decreases to a lesser extent than the lower heating value (LHV) that decreases with the addition of hydrogen.
- We have confirmed the safe use of 10-30 year old domestic combustion equipment that is not included in the scope of certification.
- Ignition experiments, flame extinction, flame interruption: during the tests, we were able to operate the equipment without problems up to 40 V/V% H<sub>2</sub> mixing in the case of convectors, and up to 30 V/V% H<sub>2</sub> mixing in the case of boilers and water heaters. Ignition experiments were successful in all equipment with 23 V/V% H<sub>2</sub> mixing.
- To test surface heating: with the addition of hydrogen, the wall temperature of the convectors decreased or remained constant, and with a good approximation constant in the case of water heaters and gas stoves.
- Changes in efficiency and harmful emissions: With the addition of hydrogen, the efficiency of most equipment decreased slightly (~1%) or was constant, except for gas stoves where it clearly decreased (<6%). The emission values typically decreased in the flue gas with the addition of hydrogen, but the trend and the degree of change are strongly dependent on the design. NO<sub>x</sub> emissions increased for one convector and one gas stove.



## 2. / DUAL-FUEL CI ICE

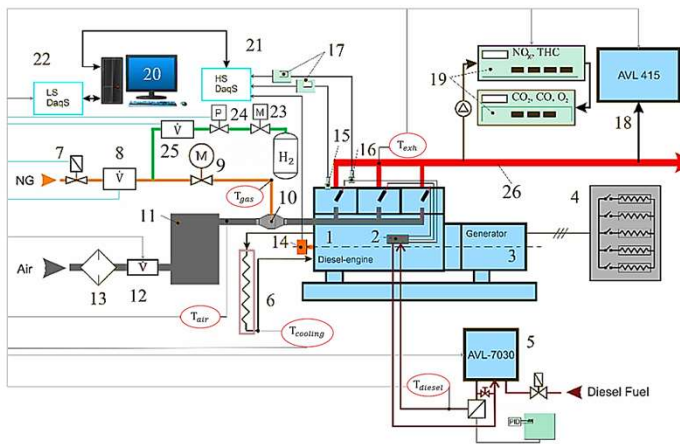
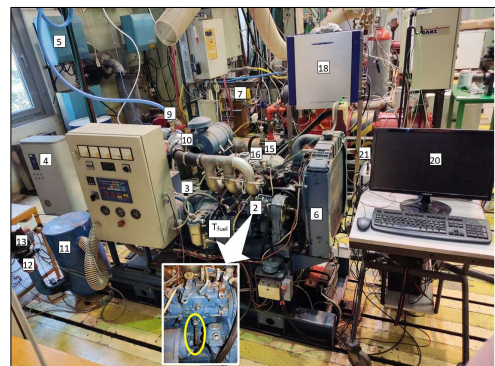
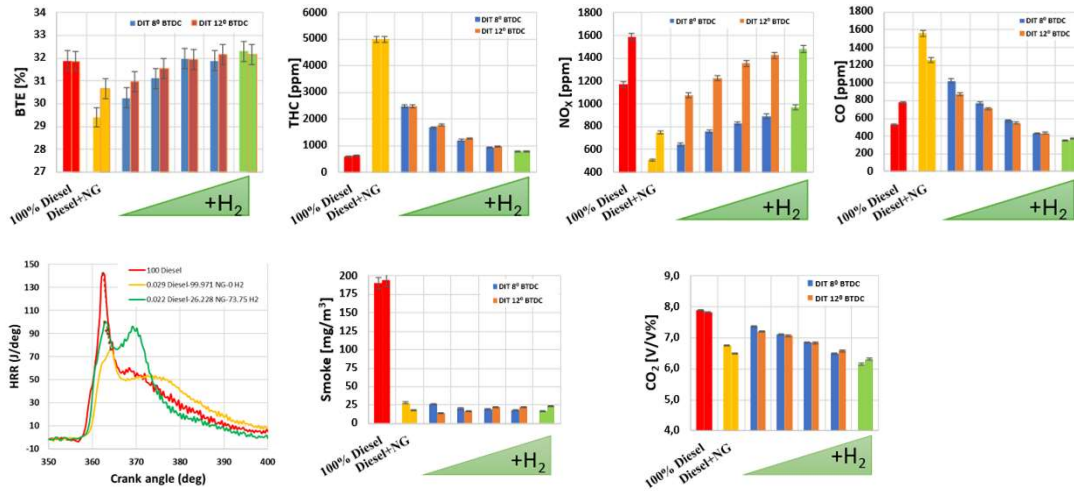

Diagram of the experimental setup



Muhssen Hassan Sadah, Ákos Bereczky, Máté Zöldy, Kristóf Lukács: The impact of hydrogen percentage on the combustion, performance, and emissions of NG-H<sub>2</sub>-diesel naturally aspirated engine at high engine load. Transportation Research Procedia (2025), accepted

## DUAL-FUEL CI ICE



Muhssen Hassan Sadah, Ákos Bereczky, Máté Zöldy, Kristóf Lukács: The impact of hydrogen percentage on the combustion, performance, and emissions of NG-H<sub>2</sub>-diesel naturally aspirated engine at high engine load. Transportation Research Procedia (2025), accepted

## 3. / GAS ENIGNS (SI ICE)

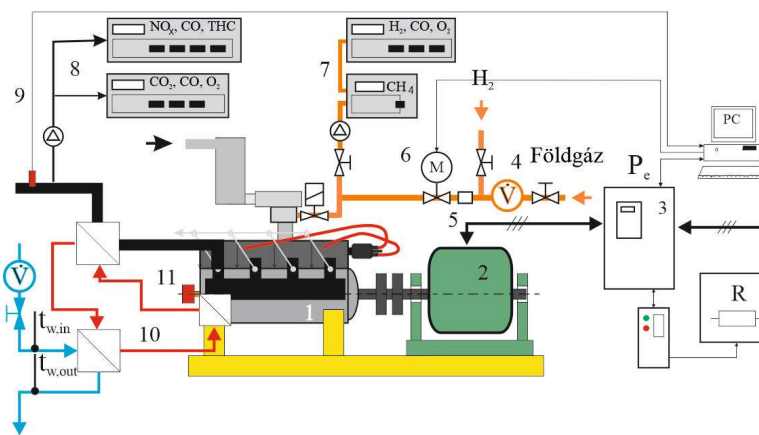
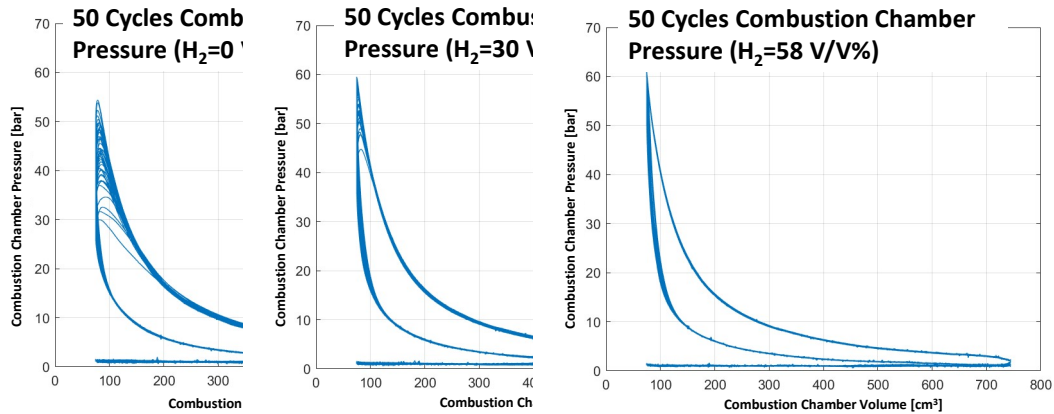

Diagram of the experimental setup



Dobi-Szakál, Gyöngy ; Szalontai, Péter ; Lukács, Kristóf ; Meggyes, Attila ; Bereczky, Ákos: Hidrogénbekeverési kísérletek energiatermelés céljára gázmotorokban, MAGYAR ENERGETIKA 30 : 1 pp. 2-6. , 5 p. (2023)

## PARAMETERS OF THE COMBUSTION CHAMBER



Combustion chamber pressure results for 1.4 Air-fuel equivalence ratio as a function of Cylinder Volume for different hydrogen mixing and pre-ignition optimised for natural gas



## IGNITION (PRE-IGNITION) OPTIMIZATION

Average combustion chamber pressure results  $\lambda=1.2$  [-] with Air to Fuel Equivalent Ratio, as a function of crankshaft angle for different hydrogen mixtures

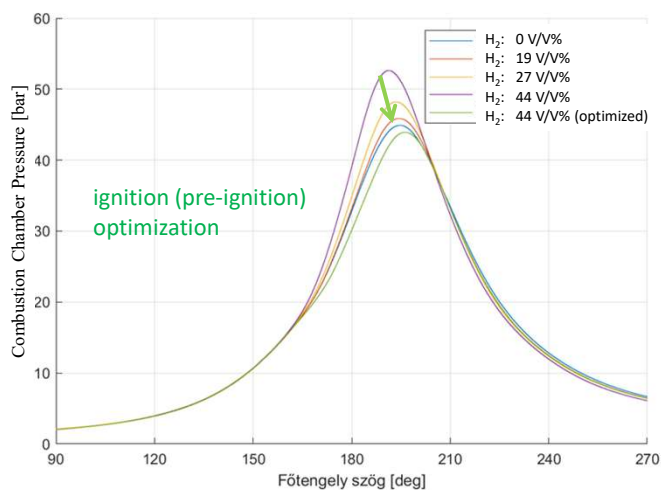

28



Dobi-Szakál, Gyöngy ; Szalontai, Péter ; Lukács, Kristóf ; Meggyes, Attila ; Bereczky, Ákos:  
Hidrogénbekeverési kísérletek energiatermelés céljára gázmotorokban, MAGYAR ENERGETIKA 30 : 1 pp. 2-6.  
, 5 p. (2023)

## HEATING VALUE AND HEAT INPUT

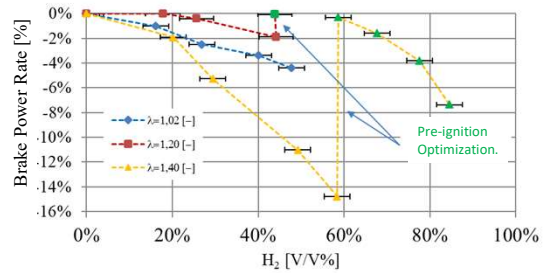
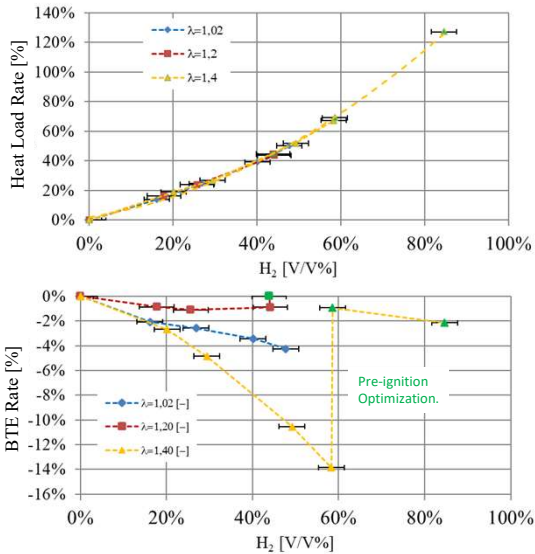

With constant air excess, the fuel flow rate increased with the addition of H<sub>2</sub>, but performance and efficiency decreased.

Combustion accelerated -> **Combustion Start (pre-ignition) Optimization.**



DEPARTMENT OF  
ENERGY ENGINEERING

Dobi-Szakál, Gyöngy ; Szalontai, Péter ; Lukács, Kristóf ; Meggyes, Attila ; Bereczky, Ákos:  
Hidrogénbekeverési kísérletek energiatermelés céljára gázmotorokban, MAGYAR ENERGETIKA 30 : 1 pp. 2-6.  
5 p. (2023)

## HARMFUL EMISSIONS

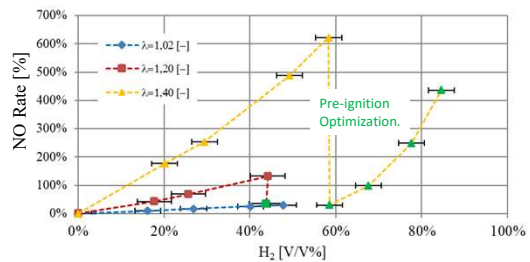
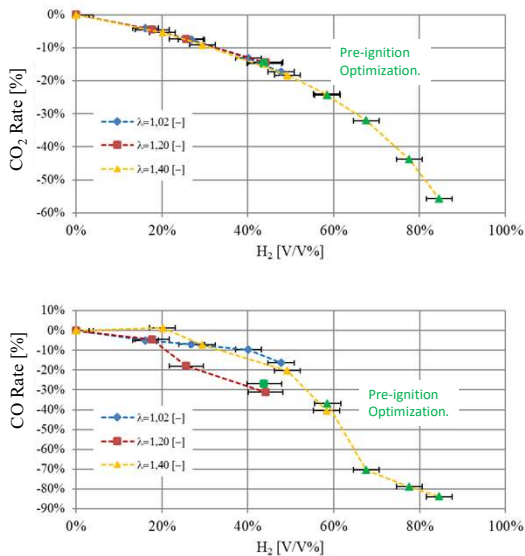

With constant air excess, the fuel flow rate increased with the addition of H<sub>2</sub>, but performance and efficiency decreased.

Combustion accelerated -> **Combustion Start (pre-ignition) Optimization.**



DEPARTMENT OF  
ENERGY ENGINEERING

Dobi-Szakál, Gyöngy ; Szalontai, Péter ; Lukács, Kristóf ; Meggyes, Attila ; Bereczky, Ákos:  
Hidrogénbekeverési kísérletek energiatermelés céljára gázmotorokban, MAGYAR ENERGETIKA 30 : 1 pp. 2-6.  
5 p. (2023)

## NH<sub>3</sub> COMBUSTION

Ammonia has poor combustion properties, but these can be improved (partially) through decomposition, resulting in a controllable flame propagation speed for H<sub>2</sub>+NH<sub>3</sub> combustion.

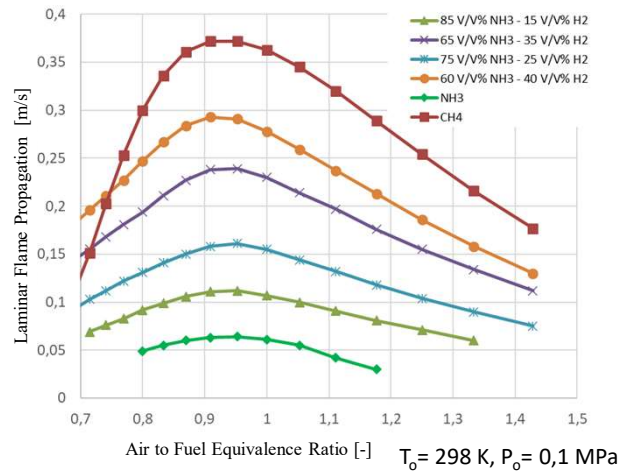

Based: Xinlu Han, Zhihua Wang, Mário Costa, Zhiwei Sun, Yong He, Kefa Cen: Experimental and kinetic modeling study of laminar burning velocities of NH<sub>3</sub>/air, NH<sub>3</sub>/H<sub>2</sub>/air, NH<sub>3</sub>/CO/air and NH<sub>3</sub>/CH<sub>4</sub>/air premixed flames, Combustion and Flame, Volume 206, 2019, Pages 214-226,



# Thank you!

- This research was in part supported by Project no. RRF-2.3.1-21-2022-00009, titled National Laboratory for Renewable Energy has been implemented with the support provided by the Recovery and Resilience Facility of the European Union within the framework of Program Széchenyi Plan Plus.



# Hydrogen-assisted combustion in a lean premixed natural gas swirl burner

Dániel Miklós Papp

Consultant:

Krisztián Sztankó

BME – Department of Energy Engineering



2025. 12. 11.

1/17

## Content

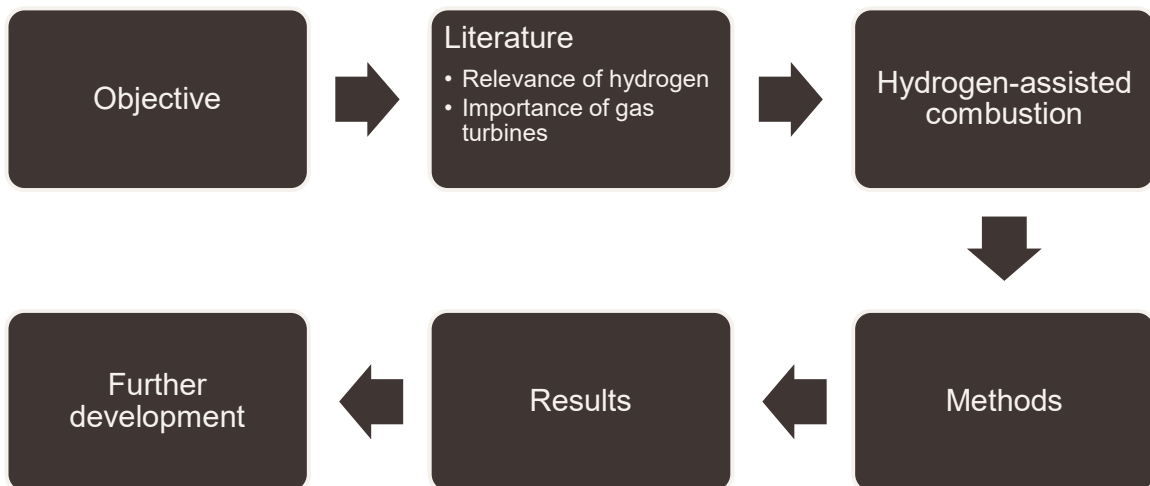

2025. 12. 11.

2/17

## Objective

- Investigation of the effects of hydrogen blending in natural gas
  - Combustion dynamics
  - High temperature intense zone in the combustion chamber
  - Emission values
- Hydrogen-assisted combustion in gas turbine
  - Mapping application possibilities

## Hydrogen

- Favorable combustion properties
  - Wider combustion range
  - Lower ignition temperature
  - Higher flame temperature
- Challenges
  - $H_2$  LHV is 1/3 of Natural gas LHV
  - High flame propagation speed
    - Danger of flashback
  - Higher flue gas temperature
    - Higher heat load at the first turbine stage

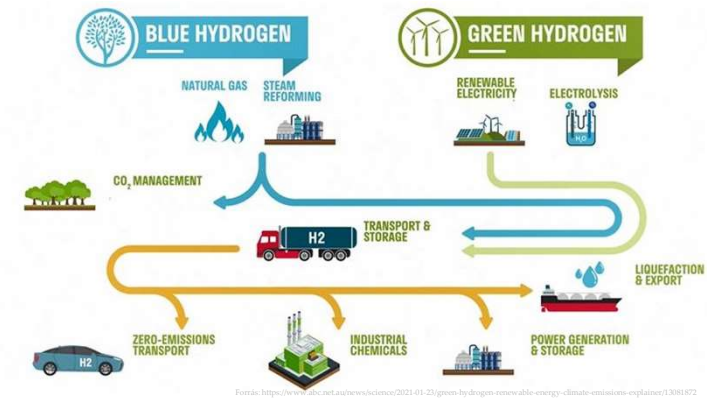

## Importance of gas turbines

Electricity grid dynamic change

↳

The share of gas turbine • Decreases

↳

Rotating mass, inertia • Decreases

↳

Difficult frequency control

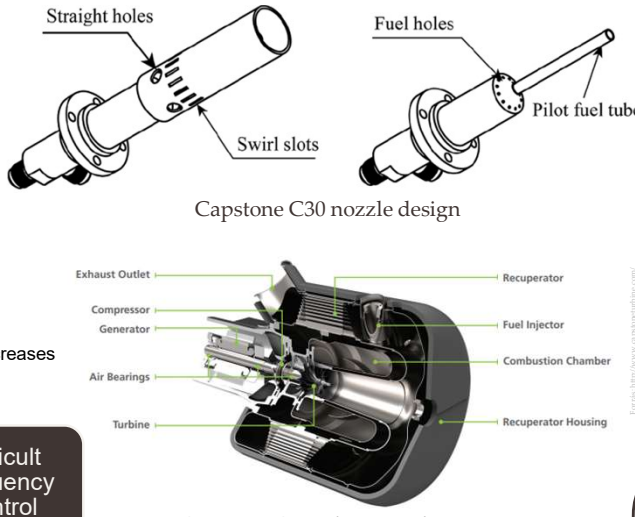

Capstone C30 nozzle design

Capstone C30 schematic drawing

2025. 12. 11.

Objective
Relevance of hydrogen
Importance of gas turbines
Hydrogen-assisted combustion
Methods
Results
Further development

5/17

## Measurement overview

- Constant thermal power – 13,35 kW
- Premixed natural gas (premix)
- Diffuse hydrogen (pilot)
- Hydrogen mixing according to P%
  - 0 – 30%
  - 30 P% ~ 60 V/V%
- Different oxygen levels
  - 3, 5, 7, 9 V/V%

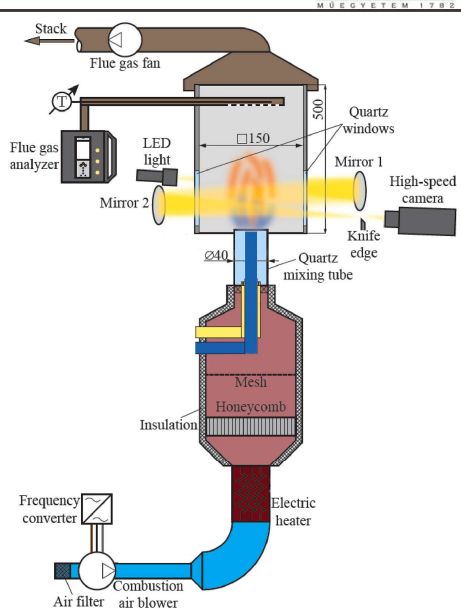

Schematic drawing of the test system

2025. 12. 11.

Objective
Relevance of hydrogen
Importance of gas turbines
Hydrogen-assisted combustion
Methods
Results
Further development

6/17



## Methods

- Schlieren optical analysis
  - 1000 image / second / measuring points
  - 28 measuring points
- Automated image processing
- PIVLAB flow visualization
- Emission measurements
  - CO<sub>2</sub>, CO, NO, NO<sub>2</sub>,

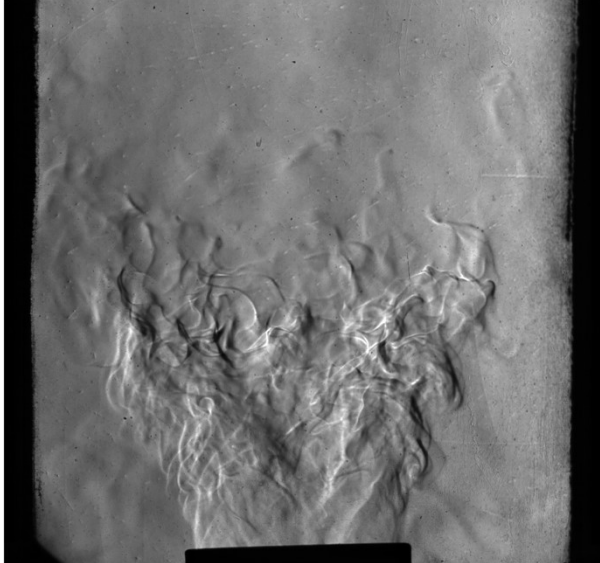

Schlieren image – 3 V/V% O<sub>2</sub>, 30 P% H<sub>2</sub>

2025. 12. 11.

Objective
Relevance of hydrogen
Importance of gas turbines
Hydrogen-assisted combustion
Methods
Results
Further development

7/17



## Emission

Carbon dioxide content with varying oxygen and hydrogen levels

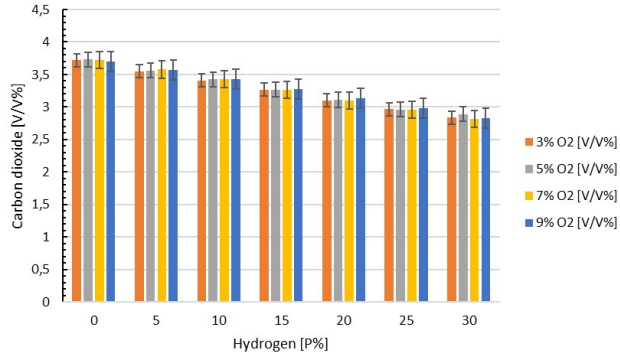

Hydrogen [P%]	3% O <sub>2</sub> [V/V%]	5% O <sub>2</sub> [V/V%]	7% O <sub>2</sub> [V/V%]	9% O <sub>2</sub> [V/V%]
0	3.6	3.6	3.6	3.6
5	3.5	3.5	3.5	3.5
10	3.4	3.4	3.4	3.4
15	3.3	3.3	3.3	3.3
20	3.2	3.2	3.2	3.2
25	3.1	3.1	3.1	3.1
30	3.0	3.0	3.0	3.0

Nitrogen oxides content with varying oxygen and hydrogen levels

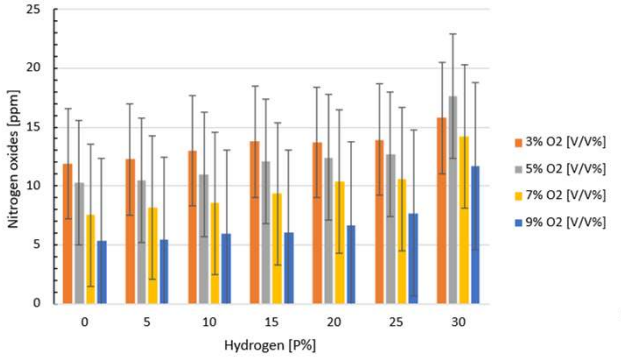

Hydrogen [P%]	3% O <sub>2</sub> [V/V%]	5% O <sub>2</sub> [V/V%]	7% O <sub>2</sub> [V/V%]	9% O <sub>2</sub> [V/V%]
0	12	10	8	5
5	13	11	9	6
10	14	12	10	7
15	15	13	11	8
20	16	14	12	9
25	17	15	13	10
30	18	16	14	11

2025. 12. 11.

Objective
Relevance of hydrogen
Importance of gas turbines
Hydrogen-assisted combustion
Methods
Results
Further development

8/17

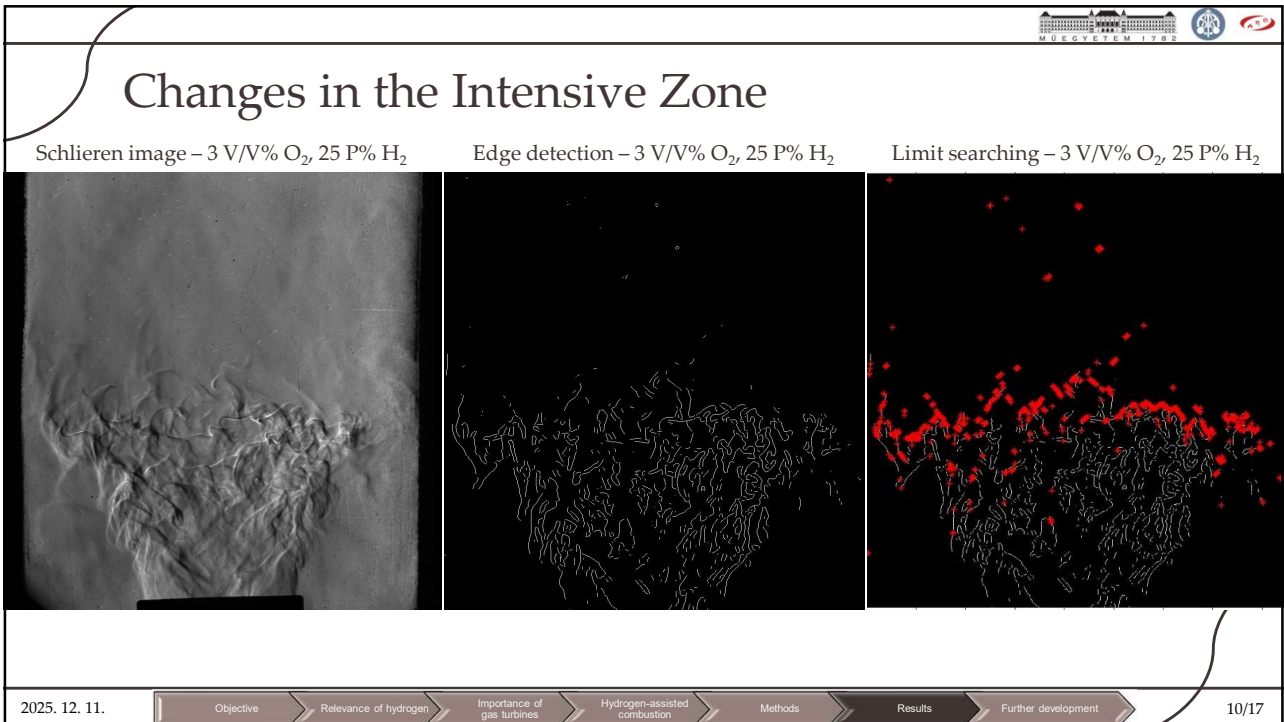
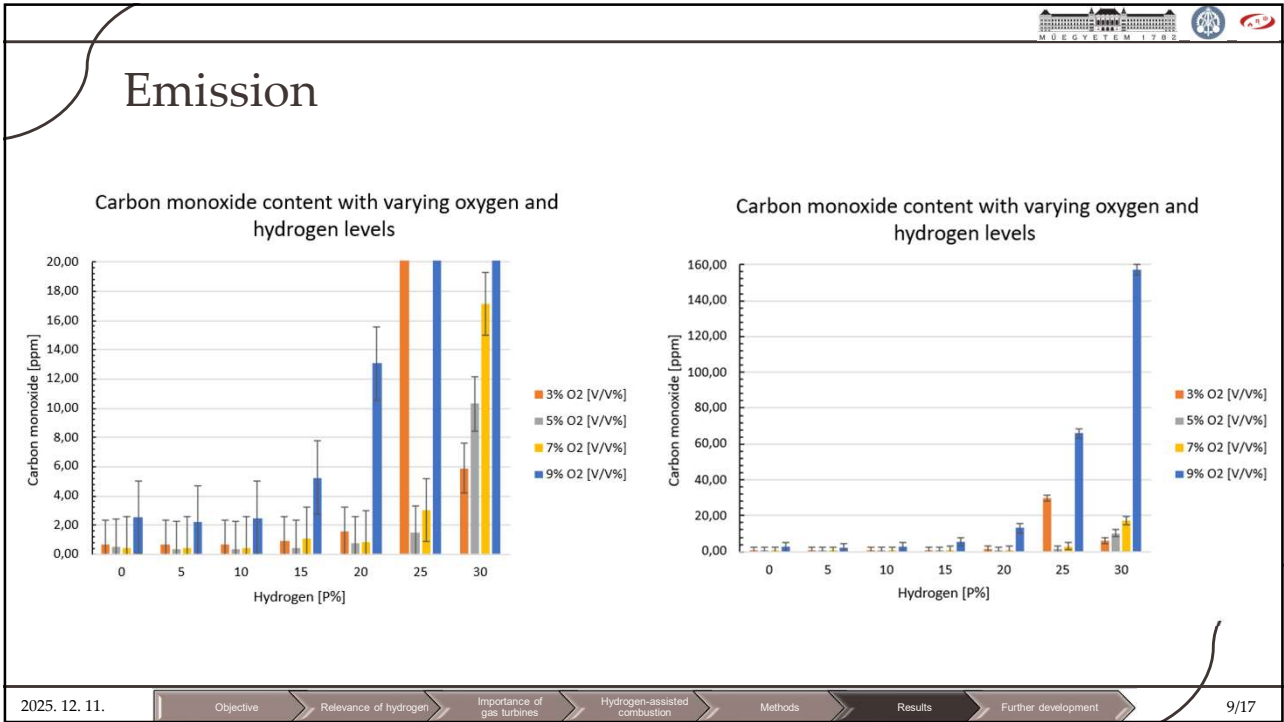

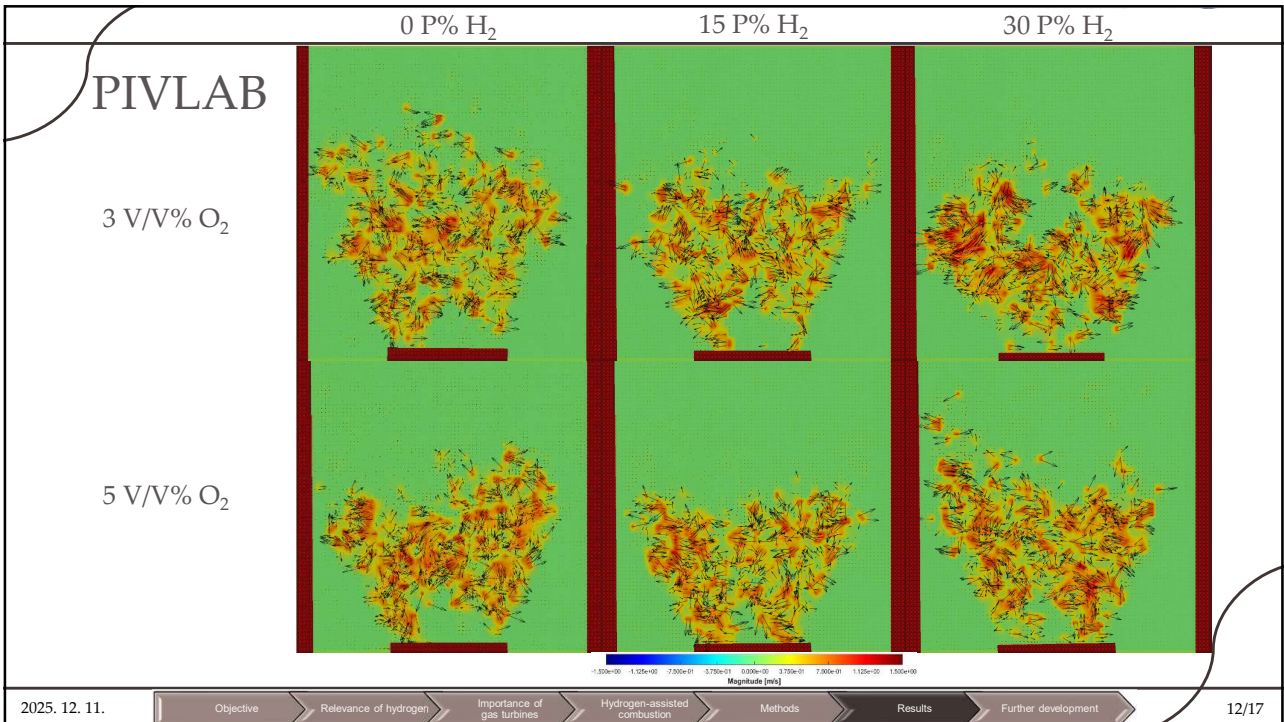
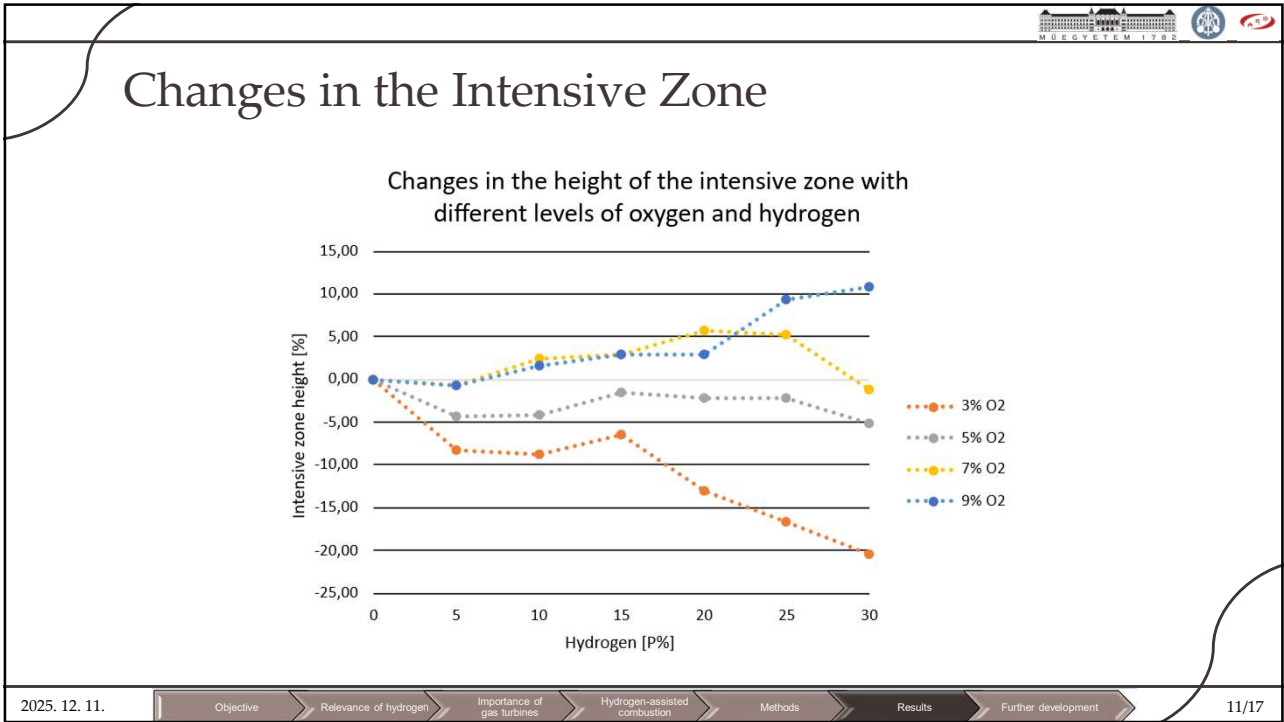

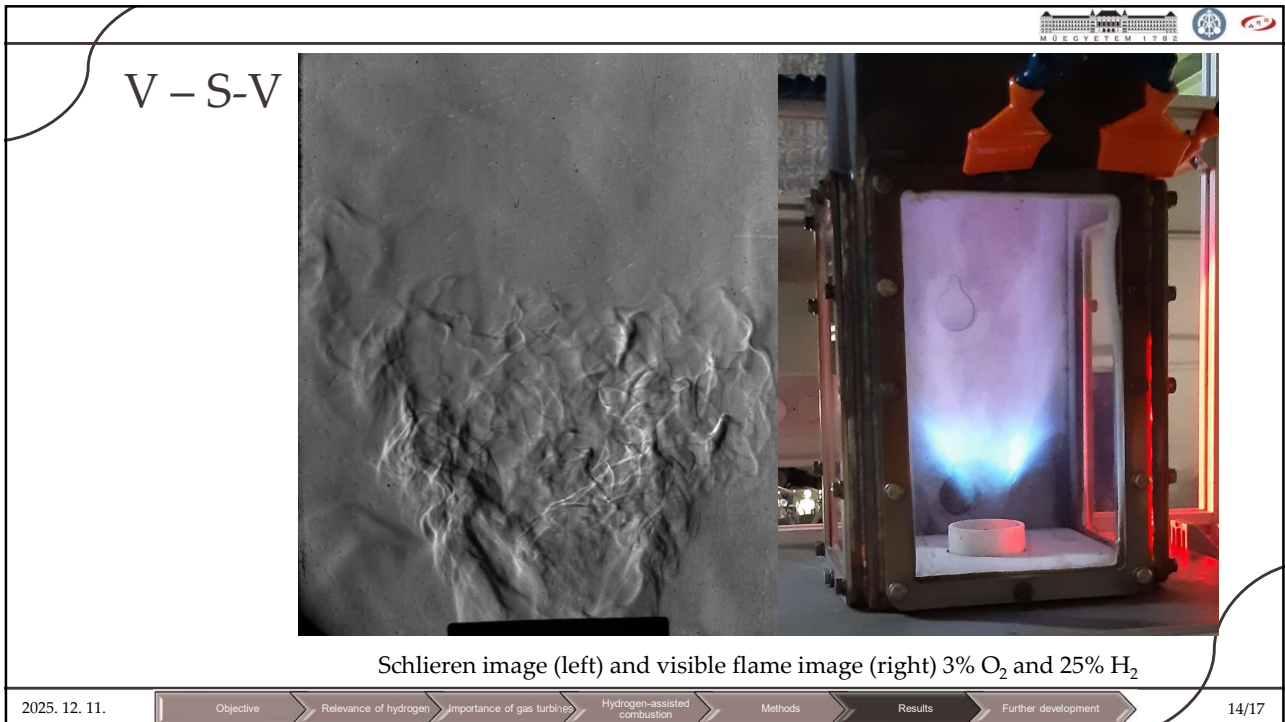
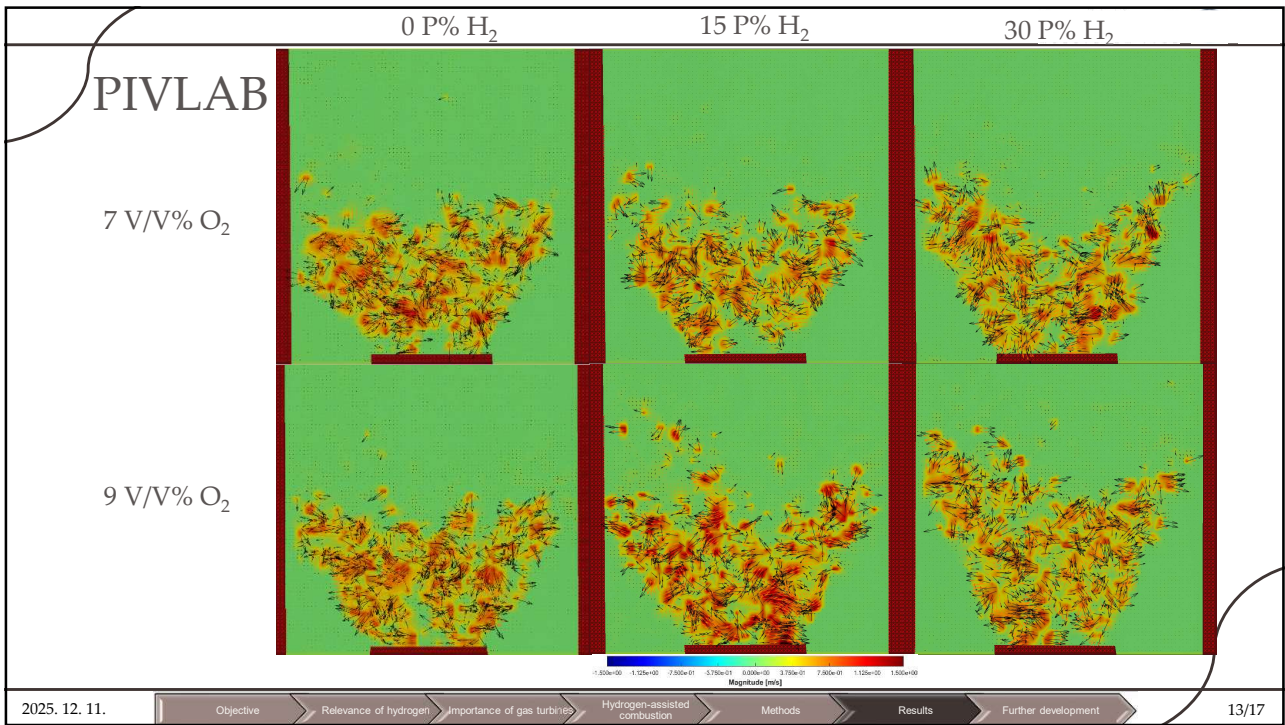

## Conclusion

- Emission
  - CO, CO<sub>2</sub>, NO<sub>x</sub>
- Intensive zone
  - Height
  - Area
- Diffuse hydrogen combustion
- Changes in excess air

2025. 12. 11.

Objective

Relevance of hydrogen

Importance of gas turbines

Hydrogen-assisted combustion

Methods

Results

Further development

15/17

## Further development

- Larger diameter pilot nozzle
- Higher hydrogen content
- Hydrogen combustion in gas turbine
  - Capstone C30 modified



2025. 12. 11.

Objective

Relevance of hydrogen

Importance of gas turbines

Hydrogen-assisted combustion

Methods

Results

Further development

16/17



**Thank you for your kind attention!**

Daniel Papp  
papp.daniel.m@eszk.org  
linkedin.com/in/daniel-papp/



2025. 12. 11. 17/17



## Higher hydrogen content

Schlieren image – 9 V/V% O<sub>2</sub>, 25 P% H<sub>2</sub>      Schlieren image – 9 V/V% O<sub>2</sub>, 40 P% H<sub>2</sub>      Schlieren image – 9 V/V% O<sub>2</sub>, 50 P% H<sub>2</sub>

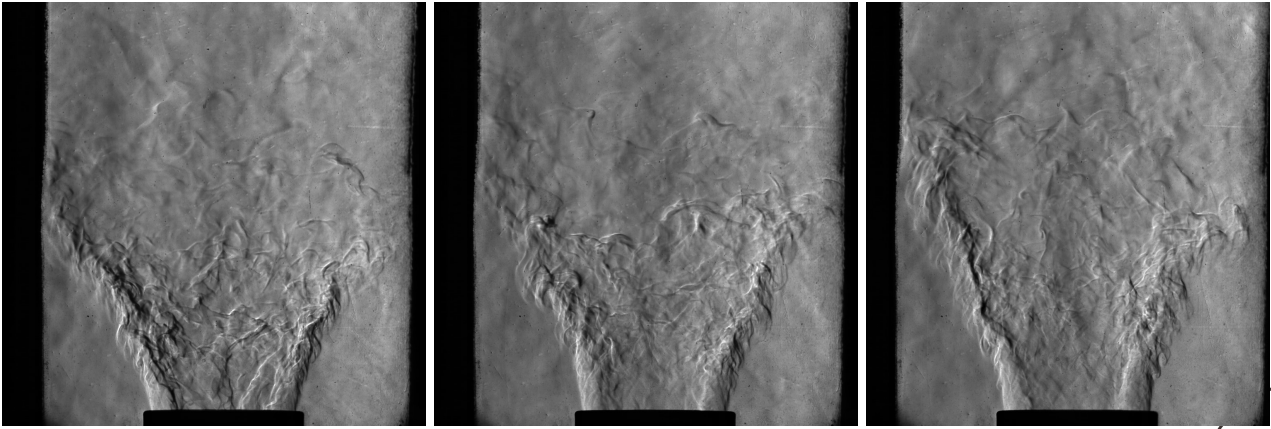

2025. 12. 11.      Objective      Relevance of hydrogen      Importance of gas turbines      **Hydrogen-assisted combustion**      Methods      Results      Further development      18/17

# Show pair

3ms Show pair image – 3 V/V% O<sub>2</sub>, 30 P% H<sub>2</sub>

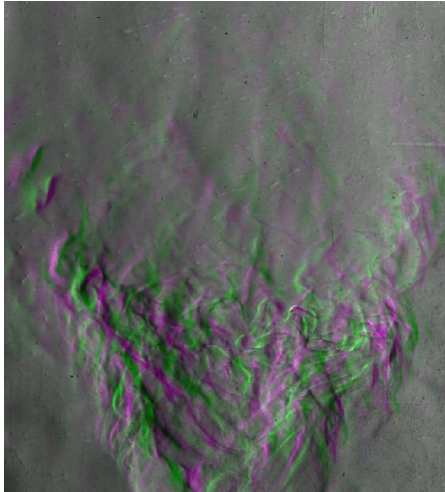

3ms Show pair image – 9 V/V% O<sub>2</sub>, 30 P% H<sub>2</sub>

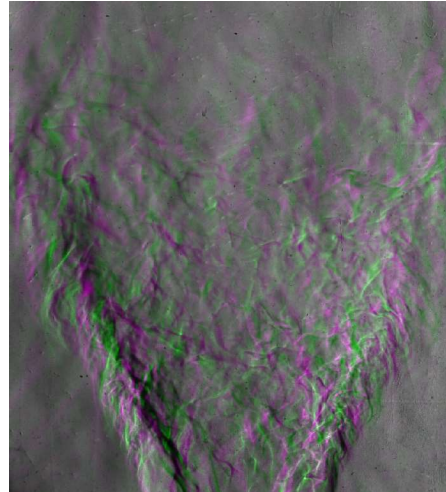



# From Nexus Thinking to Action: Renewables for Regional Cooperation

University of Miskolc,  
Miskolc, Hungary

*Jozsef Kadar*

*Center for Applied Environmental Diplomacy*



This project is part of the PRIMA programme supported by the European Union. GA n° [2243] [EcoFuture] [Call 2022 Section 1 NEXUS WEFE IA].



## What is the Arava Institute?



- Established: 1996
- Location: Kibbutz Ketura, Arava Valley
- Educational and Interdisciplinary Research Institute

ARAVA INSTITUTE  
מכון הערבה  
معهد وادي عربية



This project is part of the PRIMA programme supported by the European Union. GA n° [2243] [EcoFuture] [Call 2022 Section 1 NEXUS WEFE IA].



## EcoFuture

Partnership for Research and Innovation in the Mediterranean Area (PRIMA) - EU

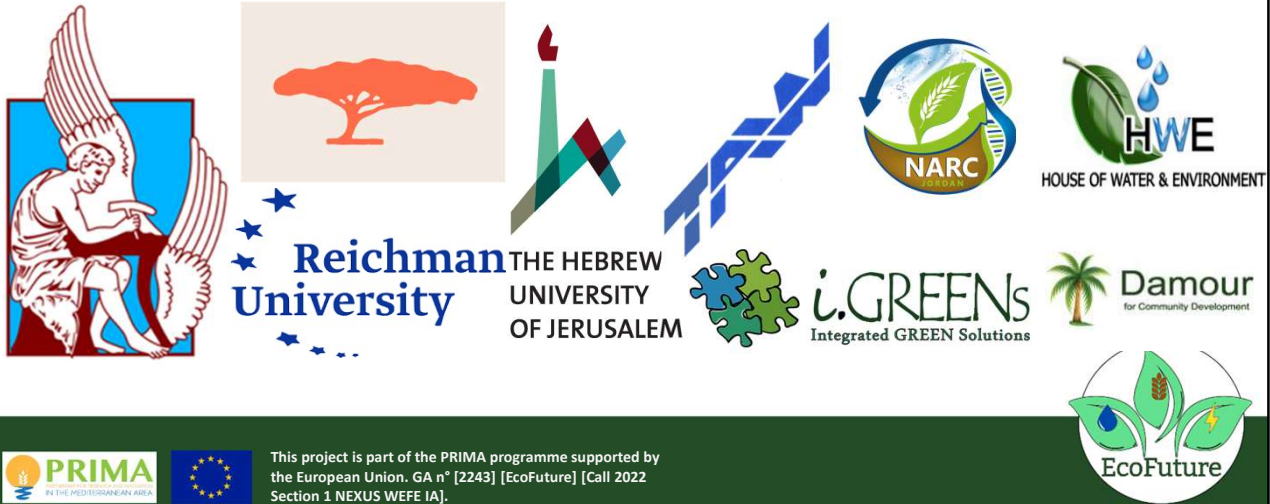

## EcoFuture

Partnership for Research and Innovation in the Mediterranean Area (PRIMA) - EU

The overall objective is to develop a **climate-change adaptation** plan oriented towards improving the socio-economic welfare for people in the **Mediterranean region** based on **Water-Energy-Food-Ecosystem (WEFE) nexus** methodologies.

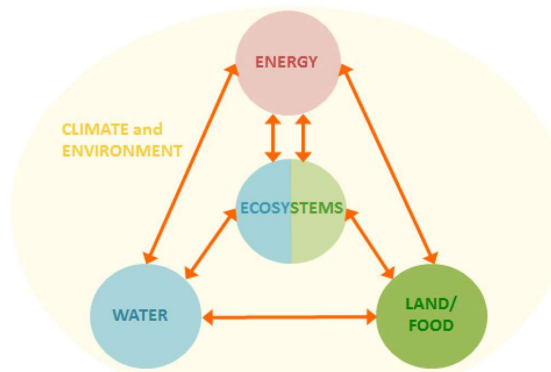

This project is part of the PRIMA programme supported by the European Union. GA n° [2243] [EcoFuture] [Call 2022 Section 1 NEXUS WEFE IA].



## EcoFuture Scope

Jordan Valley – east and west side of Jordan River

## Pilot Demonstrations

1. Eden Farm (Israel)
2. Marj Naje (Palestine)
3. Deir Alla (Jordan)

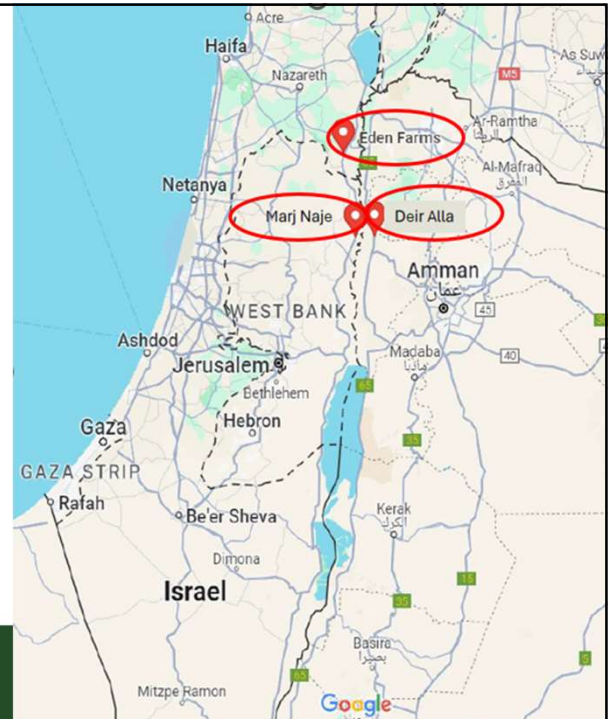

This project is part of the PRIMA programme supported by the European Union. GA n° [2243] [EcoFuture] [Call 2022 Section 1 NEXUS WEFE IA].

## Jordanian Pilot Demonstration - NARC

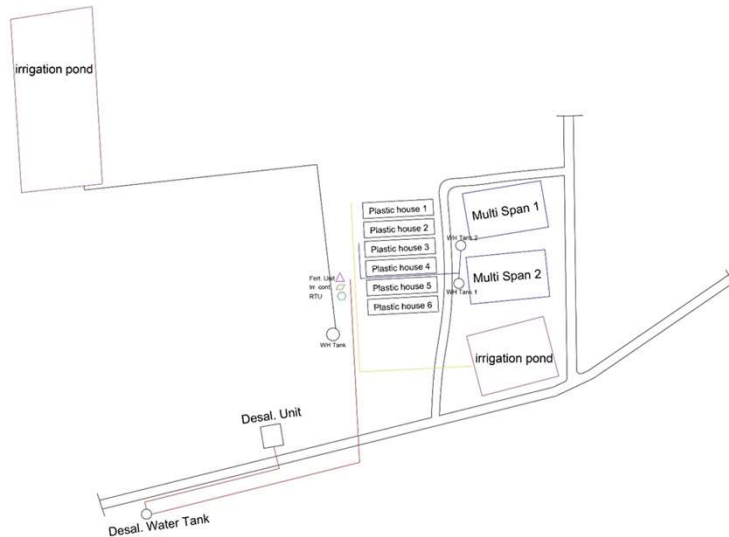

- Efficient irrigation based on soil moisture.
- Harvested rainwater.
- Compost (80%) and Manure (20%).
- Floating PV panels.
- Addition of fertilizers.
- Monitoring soil salinity and pH.
- Comparing water quantity and yield.



This project is part of the PRIMA programme supported by the European Union. GA n° [2243] [EcoFuture] [Call 2022 Section 1 NEXUS WEFE IA].





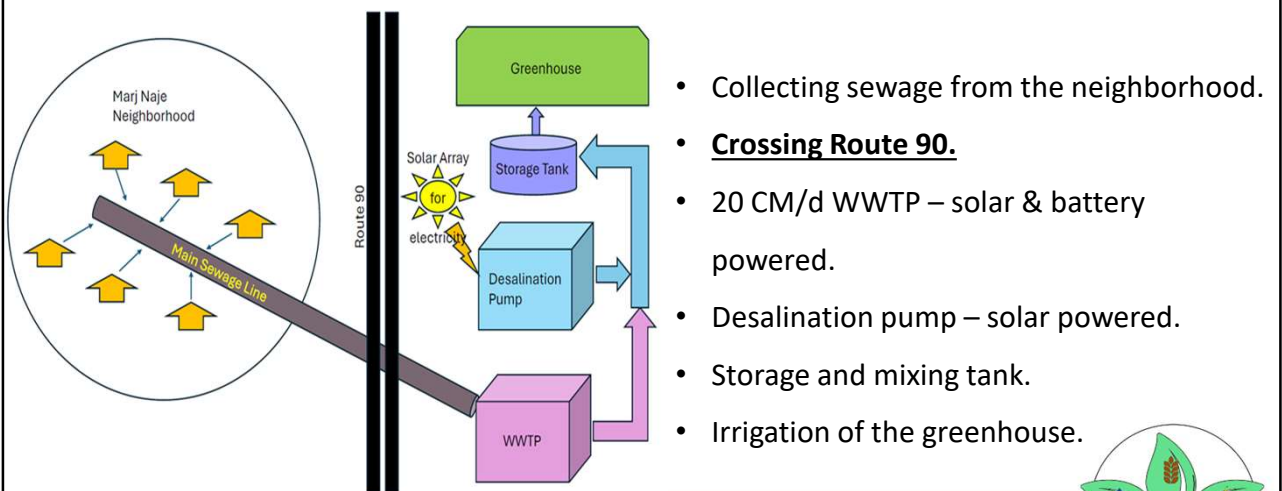

## Palestinian Pilot Demonstration - Marj Naje



- Collecting sewage from the neighborhood.
- **Crossing Route 90.**
- 20 CM/d WWTP – solar & battery powered.
- Desalination pump – solar powered.
- Storage and mixing tank.
- Irrigation of the greenhouse.



**PRIMA**  
IN THE MEDITERRANEAN AREA

 This project is part of the PRIMA programme supported by the European Union. GA n° [2243] [EcoFuture] [Call 2022 Section 1 NEXUS WEF E IA].



## Marj Naje

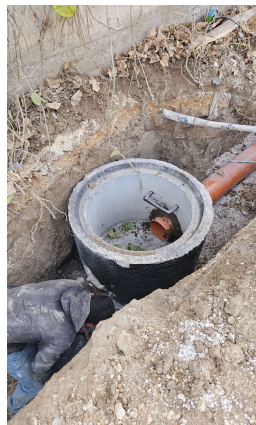
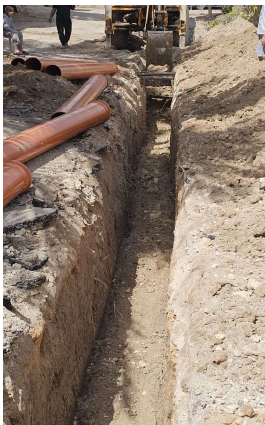

**PRIMA**  
IN THE MEDITERRANEAN AREA

 This project is part of the PRIMA programme supported by the European Union. GA n° [2243] [EcoFuture] [Call 2022 Section 1 NEXUS WEF E IA].



# Israeli Pilot Demonstration I. Nir David: Open fishpond

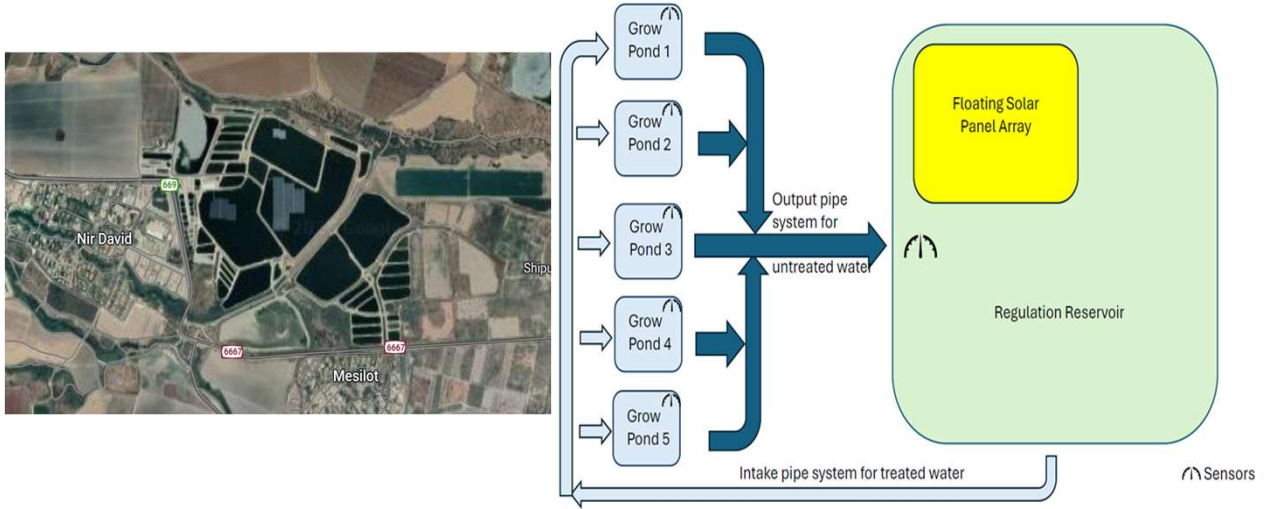

This project is part of the PRIMA programme supported by the European Union. GA n° [2243] [EcoFuture] [Call 2022 Section 1 NEXUS WEFE IA].

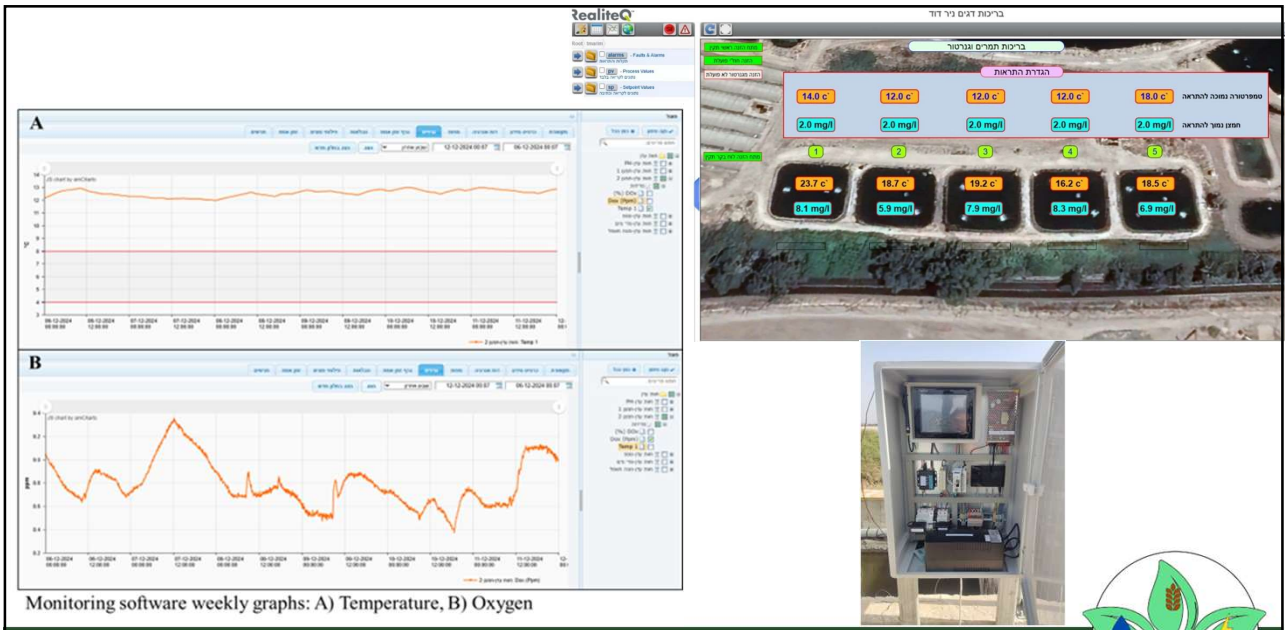

Monitoring software weekly graphs: A) Temperature, B) Oxygen



This project is part of the PRIMA programme supported by the European Union. GA n° [2243] [EcoFuture] [Call 2022 Section 1 NEXUS WEFE IA].



## Israeli Pilot Demonstration II. Eden Farm: RAS

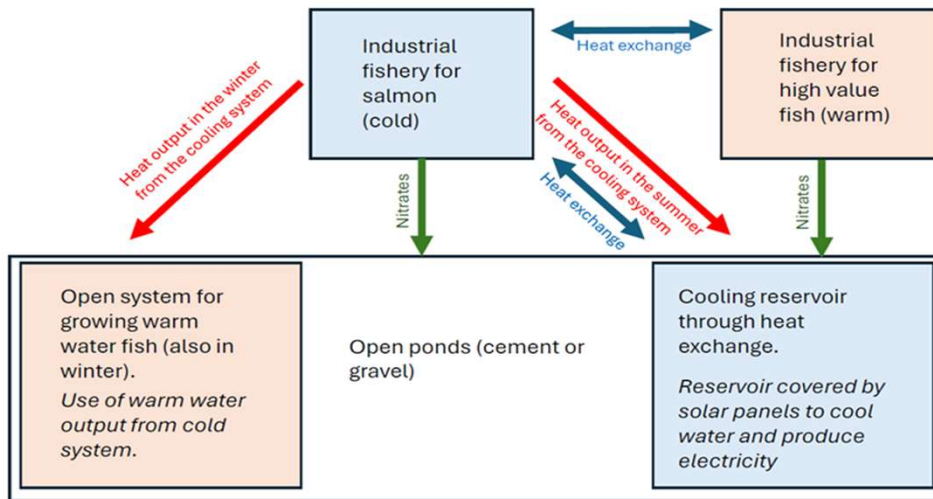

This project is part of the PRIMA programme supported by the European Union. GA n° [2243] [EcoFuture] [Call 2022 Section 1 NEXUS WEFE IA].

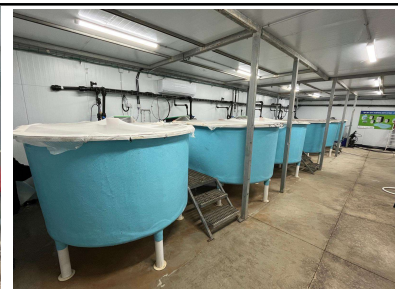

This project is part of the PRIMA programme supported by the European Union. GA n° [2243] [EcoFuture] [Call 2022 Section 1 NEXUS WEFE IA].



## Strategic Planning for Sustainable Development – 3 scenarios

- Business As Usual – Baseline
- Incremental Improvements – Short-term (5-10 years) – National
- Blue Sky – Long-term (25 – 30 years) - Regional



This project is part of the PRIMA programme supported by the European Union. GA n° [2243] [EcoFuture] [Call 2022 Section 1 NEXUS WEFE IA].

## Blue Sky – Long-term (25 – 30 years) - Regional

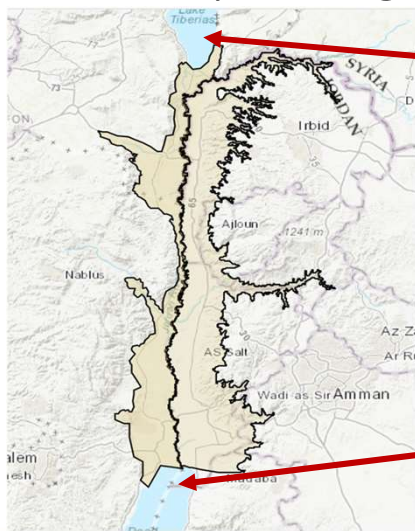

Lake Tiberias

Dead Sea

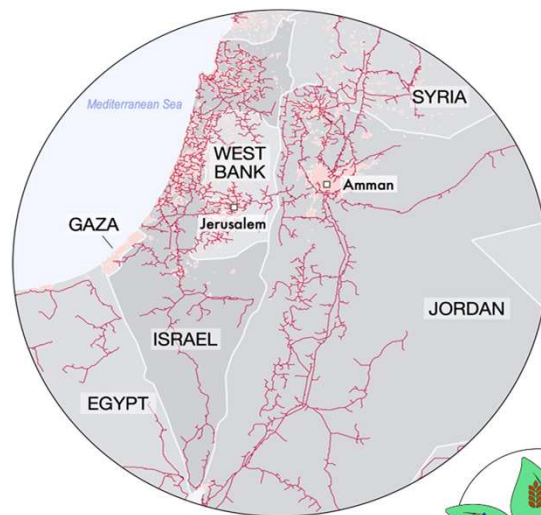

This project is part of the PRIMA programme supported by the European Union. GA n° [2243] [EcoFuture] [Call 2022 Section 1 NEXUS WEFE IA].

## Renewables in the Middle East



Electricity (imported/fossil-based)  
8.8%

Oil Products (fossil)  
77.7%

Renewable Energy (renewables)  
13.6%



This project is part of the PRIMA programme supported by the European Union. GA n° [2243] [EcoFuture] [Call 2022 Section 1 NEXUS WEFE IA].



## Blue Sky – Long-term Scenario

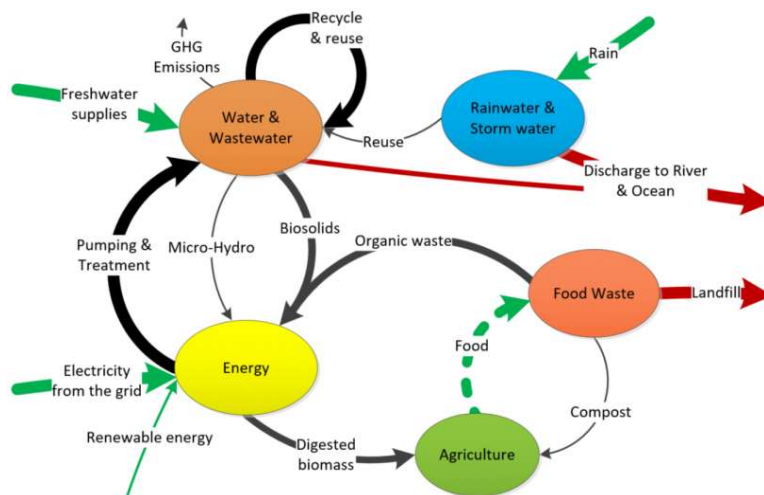

This project is part of the PRIMA programme supported by the European Union. GA n° [2243] [EcoFuture] [Call 2022 Section 1 NEXUS WEFE IA].





### Follow Us



-  [www.ecofuture-prima.eu](http://www.ecofuture-prima.eu)
-  [facebook.com/  
ecofuture-prima](https://facebook.com/ecofuture-prima)
-  [@EcoFuture\\_prima](https://twitter.com/EcoFuture_prima)
-  [@EcoFuture-prima](https://youtube.com/EcoFuture-prima)

ENERGYWATERFOODCLIMATE  
**NEXUS**<sup>®</sup>  
INTERNATIONAL SUMMIT



**AUGUST 26-28, 2025**  
**EUROPE**  
MISKOLC, HUNGARY

# BIOGAS UPGRADING WITH AQUATIC PLANTS

**Gábor Nagy**  
Institute of Energy, Ceramics and Polymer Technology  
University of Miskolc

**MISKOLCI**  
EGYETEM  
UNIVERSITY OF MISKOLC



## Biogas utilization

- Nowadays, global warming is one of the biggest problems of humanity
- This is the basis of many negative global phenomena
- Global warming is accelerated by CO<sub>2</sub> emission from the burning of fossil fuels
- Replacing these fuels with renewable ones can help slow down global changes
- For example, natural gas can be replaced by biogas for heat and electricity production

## Biogas or biomethane?

- If the methane content of biogas is separated from the other components (biogas upgrading), the resulting gas (biomethane) is suitable for replacing natural gas in all aspects
- Distribution of global biogas and biomethane production:
  - EU: ~50%
  - China: ~20%
  - USA: ~10%
  - India: ~10%

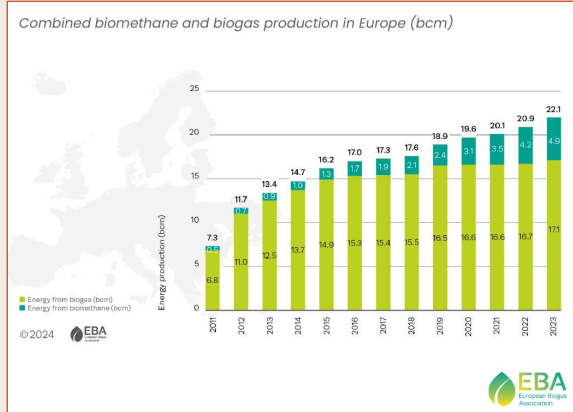

## Some results from the literature <sup>1</sup>

- Almost all organic materials are suitable for biogas production, for example aquatic plants

Aquatic plant	Gas yield, L/kg <sub>VS</sub>
Duckweed	290 – 390
Water hyacinth	140 – 290
Water lettuce	30 – 170
Water moss	6 – 50
Water fern	130 – 200
Pondweed	160 – 400
Brazilian waterweed	250 – 300
Hornwort	240 – 430
Common reed	20 – 300
Cattail	20 – 280

Mixtures with:

- Cow manure
- Llama manure
- Sheep manure
- Pig manure/slurry
- Rumen/slaughterhouse waste
- Sewage sludge
- Landfill leachate
- Quinoa stalk
- Cassava starch
- Food waste
- Paper waste
- Banana peel

<sup>1</sup> G. Nagy: The application and treatment of freshwater macrophytes as potential biogas base materials: A review. Renewable and Sustainable Energy Reviews. (199) 2024, 114513



## Floating fern (*Salvinia natans*)

- Free floating
- 1-2 cm long leaves
- In large amounts, it can cover entire lakes, starving other plant species



<https://powo.science.kew.org/>

7

## Water lettuce (*Pistia stratiotes*)

- Free floating
- 5 - 15 cm long leaves
- It is an invasive species, it can spread by fragmentation too.
- In waters with high nutrient content, it can overgrow and can block gas exchange on the surface water.

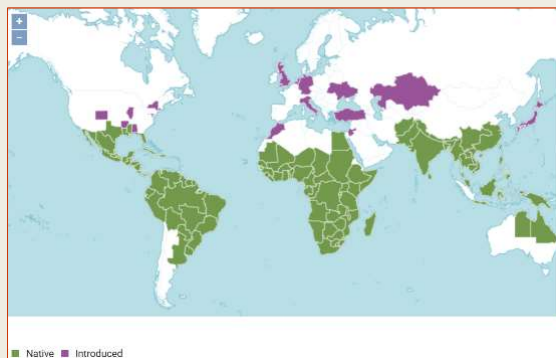

<https://powo.science.kew.org/>

8

## Cattail (*Typha latifolia*)

- Emergent, waterfront plant
- 1.5 – 3 m high
- It has great importance of stabilizing water banks and cleaning water bodies

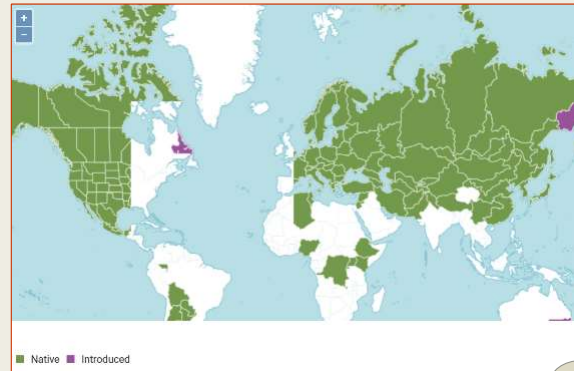
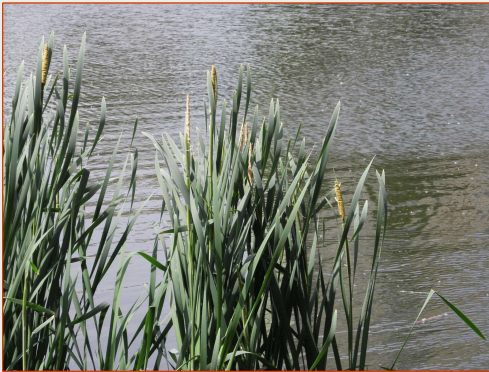

<https://powo.science.kew.org/>

9

## Straight Vallisneria (*Vallisneria spiralis*)

- Submerged aquatic plant
- Maximum 1 m long leaves
- Invasive species, because of its vegetative reproduction and high growing rate

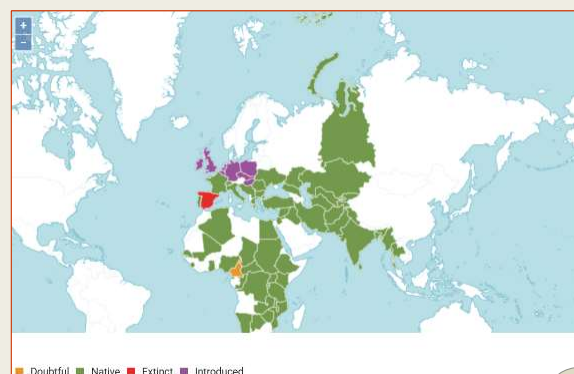

<https://powo.science.kew.org/>

10

## Brazilian waterweed (*Egeria densa*)

- Submerged aquatic plant
- Maximum 2 m long stems
- Invasive species, because of its vegetative reproduction and high growing rate



<https://powo.science.kew.org/>

11

## Experiment I.

- The aim was to investigate the effect of addition of aquatic plants on biogas quality and quantity
- Base material: pig slurry
- Aquatic plants: floating fern, water lettuce, cattail and straight Vallisneria

12

## Reactors

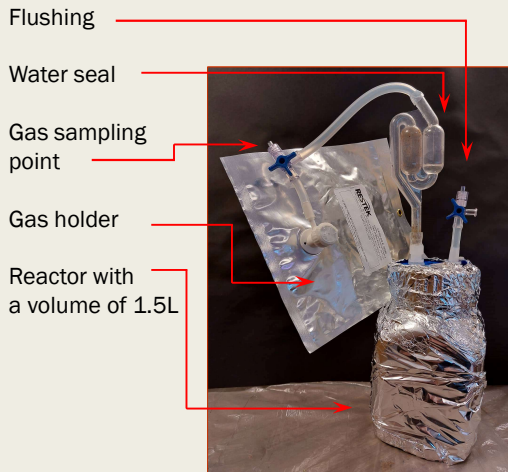

Temperature-controlled water bath

13

## Used materials

Parameters		Base materials					
		Pig slurry	Seeding material*	Water lettuce	Cattail	Flotaing fern	Vallisneria
Dry basis	N, w/w%	3.01	6.37	2.46	3.21	0.76	2.43
	C, w/w%	39.16	36.36	32.60	41.91	19.92	31.06
	H, w/w%	5.63	5.08	4.62	5.89	2.01	3.98
	S, w/w%	0.33	0.85	0.25	0.23	0.14	0.42
	C/N ratio, -	13.0	5.7	13.3	13.0	26.3	12.8
Original material	Moisture, w/w%	92.4	97.1	94.8	88.1	92.3	93.4
	pH, -	6.9	8.53	-	-	-	-

### Mixtures used during the experiment:

#### 0% mixtures

1000 g pig slurry or aquatic plant (dry basis)  
+ 200 g seeding material (in original condition)

#### 10% mixtures:

1000 g pig slurry (dry basis)  
+ 100 g plant (dry basis)  
+ 200 g seeding material (in original condition)

#### 20% mixtures:

1000 g pig slurry (dry basis)  
+ 200 g plant (dry basis)  
+ 200 g seeding material (in original conditions)

\* Seeding material: digested slurry from a biogas plant operating at mesophilic conditions

14

## Operating parameters

- Reactor volume: 1.5 L
- Amount of raw material: 1000 g
- Solid matter content of loaded material: 5 w/w%
- Reactor temperature: 34 °C (mesophilic condition)

15

## Daily biogas yield

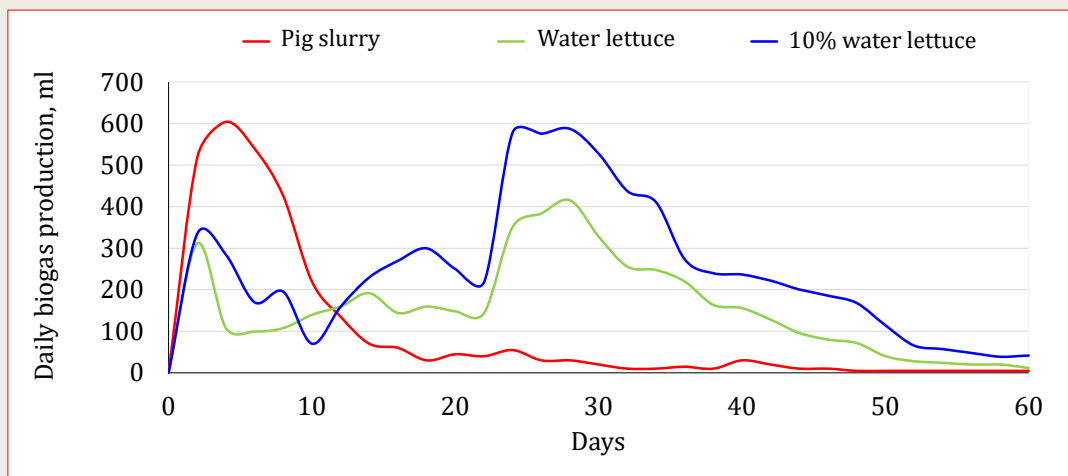

16

## Total biogas yield

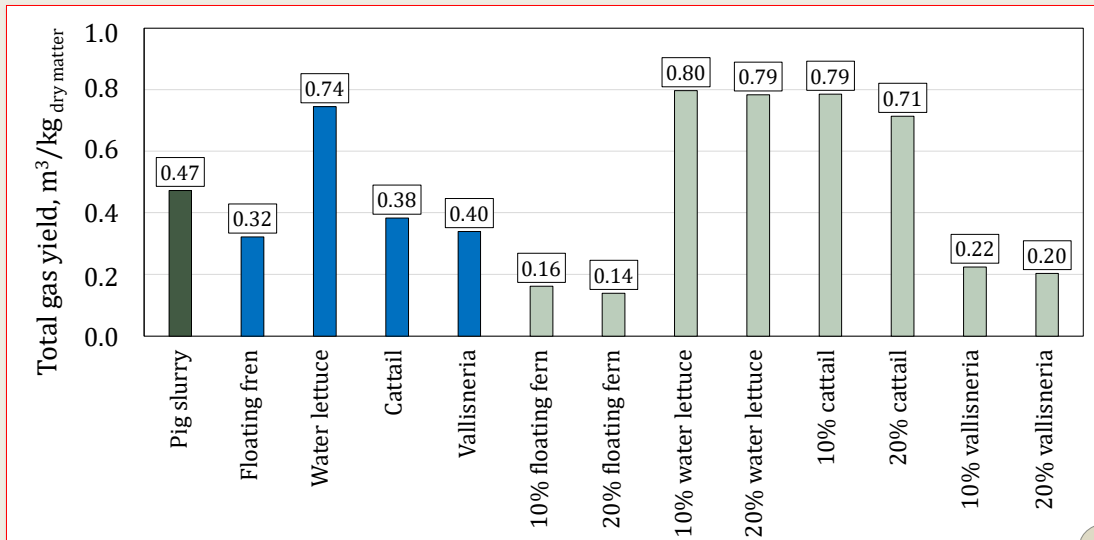

17

## Average methane content

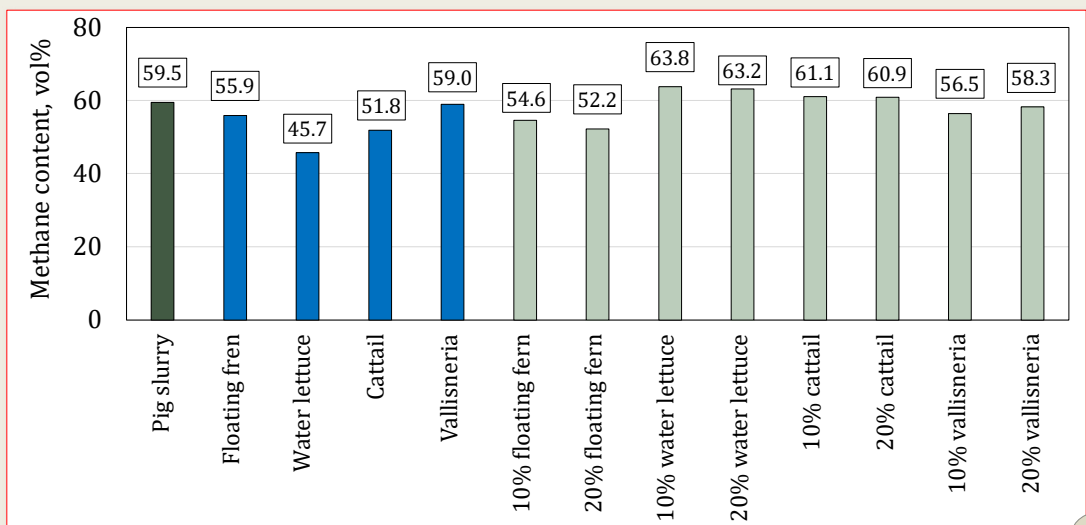

18

## Experiment II.

- The aim was to investigate the aquatic plant-based biogas cleaning system
- Base material: sheep manure
- Aquatic plants: straight Vallisneria and Brazilian waterweed

19

## Experimental system

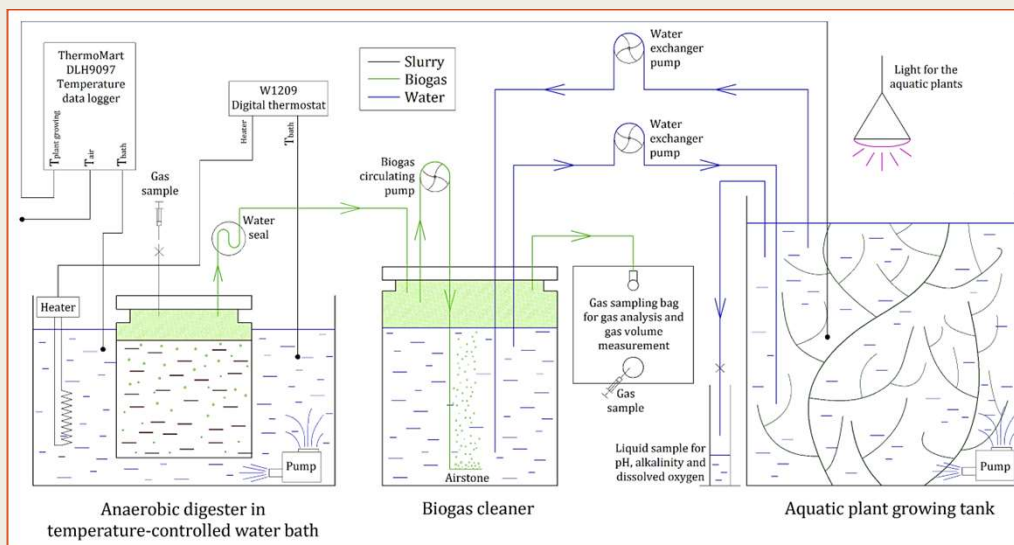

20

## The implemented system



21

## Used materials

Parameters		Base materials		
		Sheep manure	Straight Vallisneria	Brazilian waterweed
Dry basis	N, w/w%	2.59	2.86	3.94
	C, w/w%	29.28	33.32	36.04
	H, w/w%	3.85	4.69	5.51
	S, w/w%	0.70	0.65	0.44
	C/N ratio, -	11,3	11,7	9.2
Original material	Moisture, w/w%	51.9	93.4	92.1
	pH, -	7.68	-	-

### Mixtures used during the experiment:

#### 0% mixtures

1000 g sheep manure (dry basis)  
+ 200 g seeding material (in original condition)

#### 6% mixtures:

1000 g sheep manure (dry basis)  
+ 60 g plant (dry basis)  
+ 200 g seeding material (in original condition)

22

## Operating parameters

- Reactor volume: 1.5 L
- Amount of raw material: 1000 g
- Solid matter content of loaded material: 5 w/w%
- Reactor temperature: 34 °C (mesophilic condition)
- Capacity of wet scrubber: circulating of 10 L gas /h
- Volume of aquatic plant growing tank: 10 L
- Water exchange between the biogas scrubber and aquatic plant growing tank: 3x60 min/day (5 L/day)

23

## Daily biogas yield

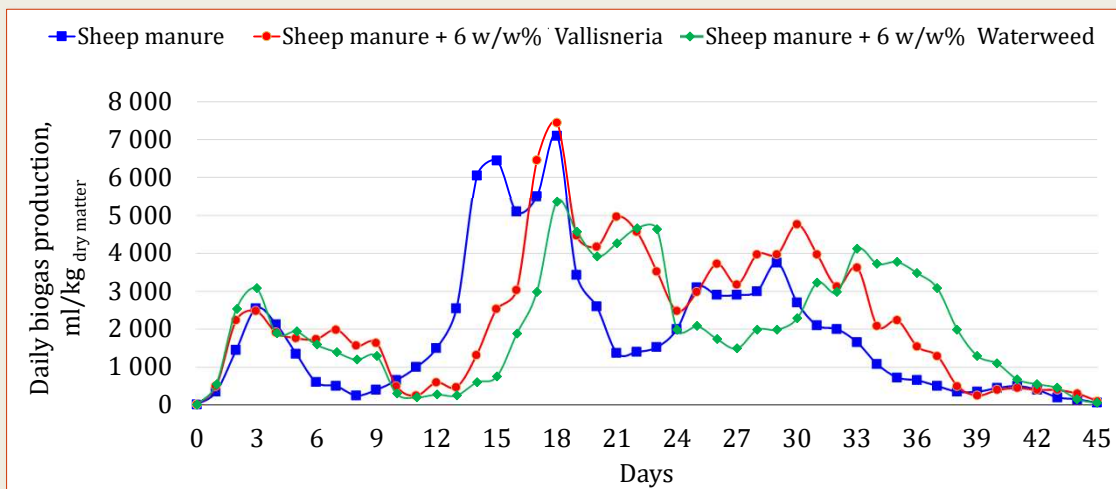

24

## Total biogas yield

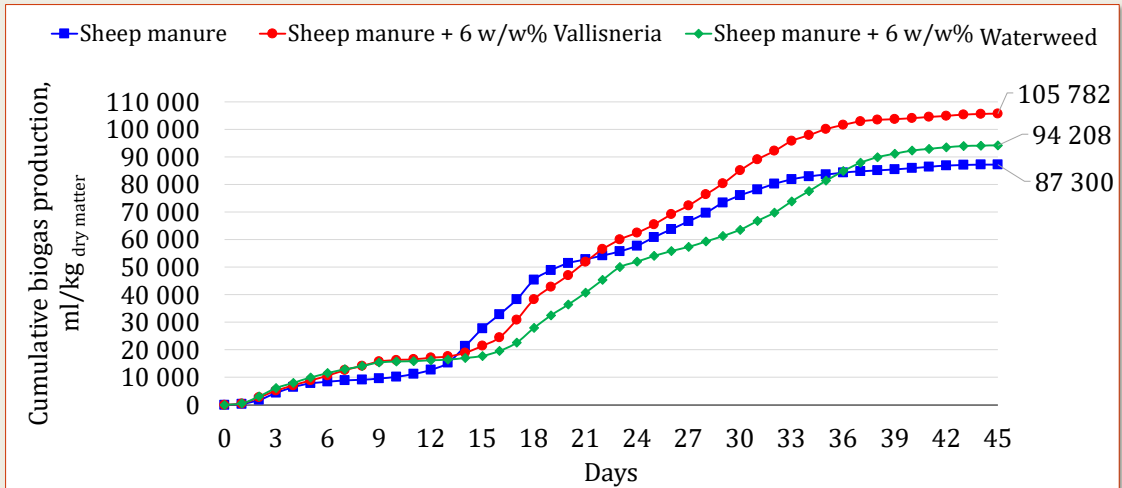

25

## The changes of CH<sub>4</sub> and CO<sub>2</sub> content of biogas

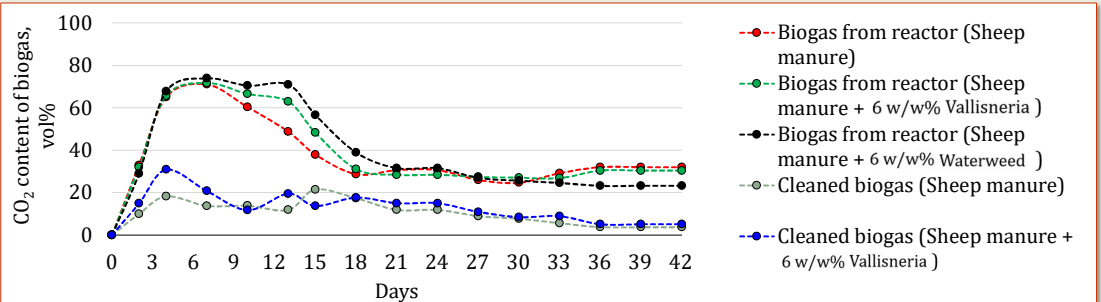
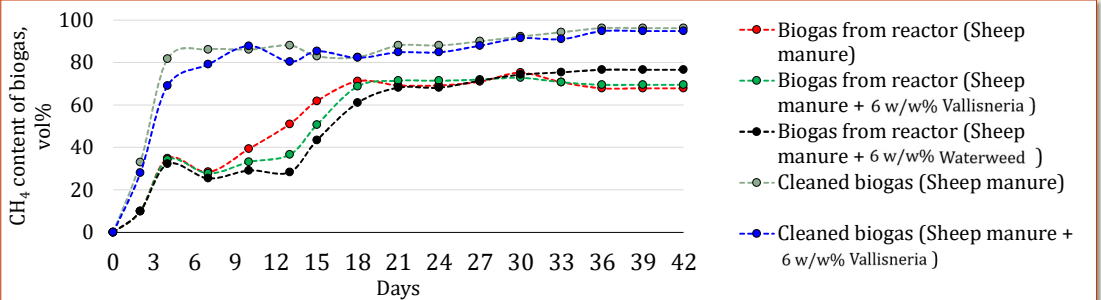

26

### The changes of H<sub>2</sub>S content of biogas

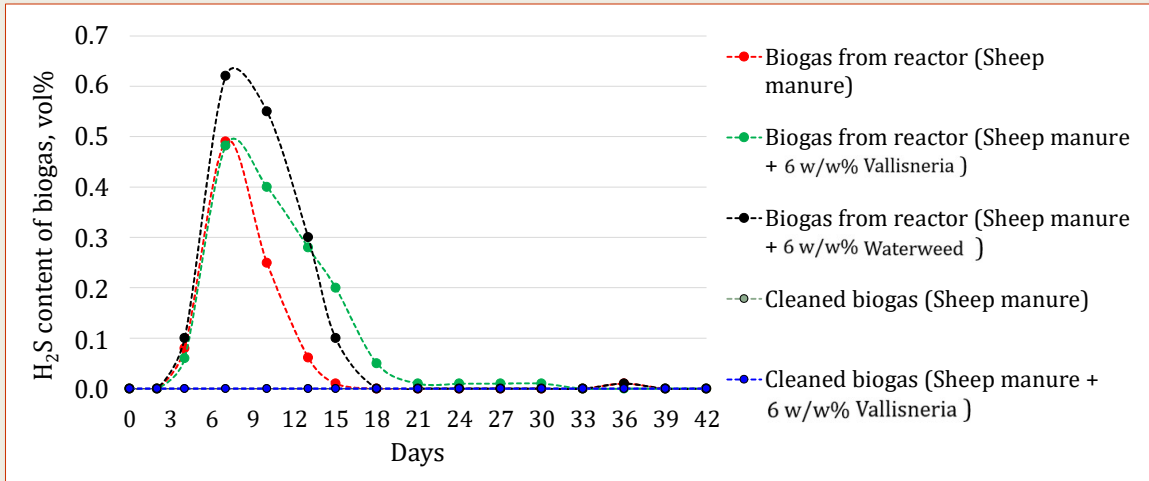

### The plants from the experiments

Brazilian waterweed

Size after 6 weeks

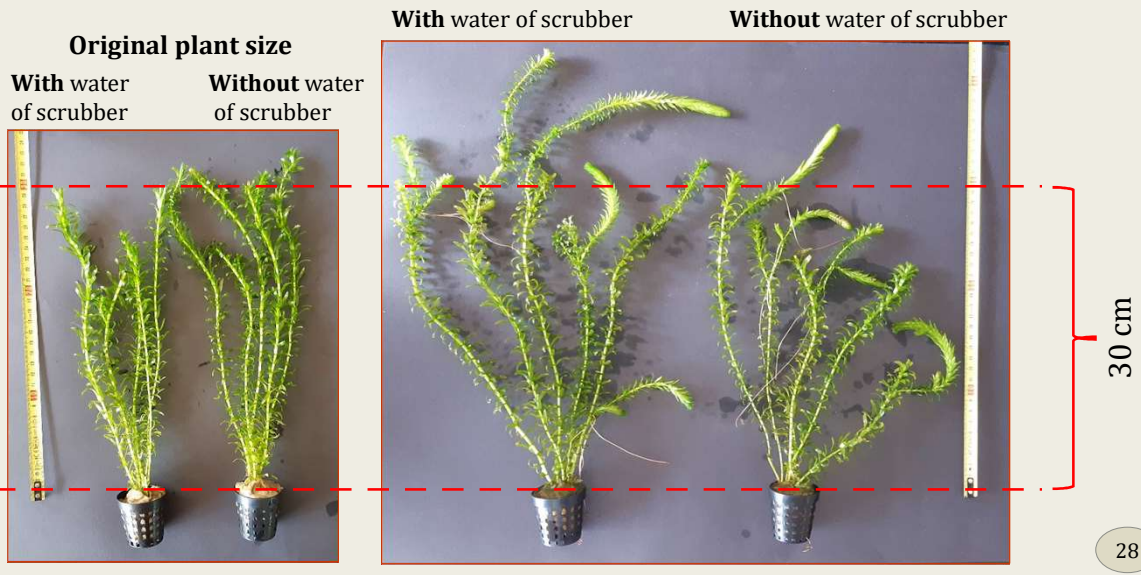

## The plants from the experiments Straight Vallisneria

### Original plant size

With water of scrubber

Without water of scrubber

### Size after 6 weeks

With water of scrubber

Without water of scrubber



29

## Sizes of plants

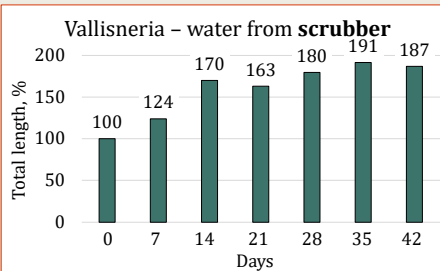
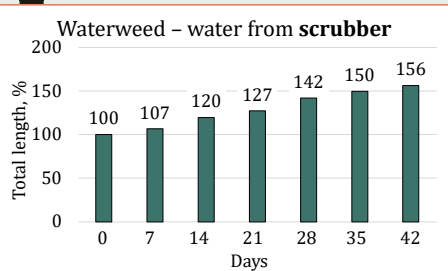
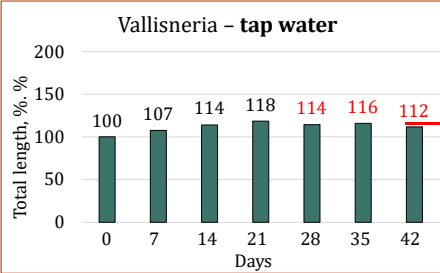
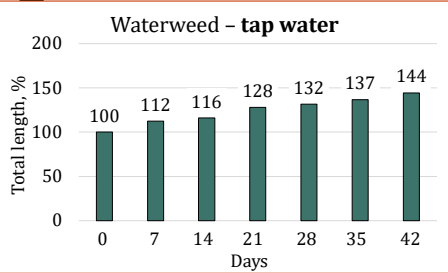

■ Total length of Vallisneria =  $\sum$  length of all leaves

■ Total length of waterweed =  $\sum$  length of all stems

30

## Conclusions

- Aquatic plants may be suitable for biogas production or as a feedstock additive, but as you can see, not all plants are suitable for all conventional feedstocks
- Aquatic plants can be used in biogas upgrading
- Currently, there is little literature data and systematic experiments
- For example, the economics cannot be determined
- Therefore, much more research is needed on this topic, including biogas production and gas purification

31

## Thank you for your attention!

- **Gábor Nagy**  
Institute of Energy, Ceramics and Polymer Technology  
University of Miskolc  
[gabor.nagy2@uni-miskolc.hu](mailto:gabor.nagy2@uni-miskolc.hu)



32

## An experimental study to improve Geothermal Heat pump efficiency by testing improved soil mixture

**Setting up: Salman Brbhan,  
PhD Student**

Institute of Energy Engineering and Chemical Machinery,  
Faculty of Mechanical Engineering and Informatics,  
University of Miskolc, Hungary



AUGUST 26-28, 2022  
EUROPE  
MISKOLC, HUNGAR

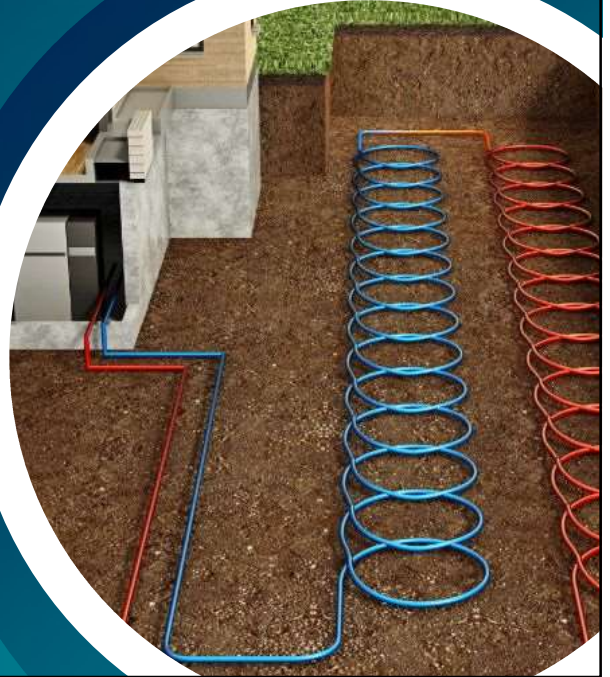

## Agenda

- Introduction
- Materials and Methodology
- Results and discussion
- Conclusion

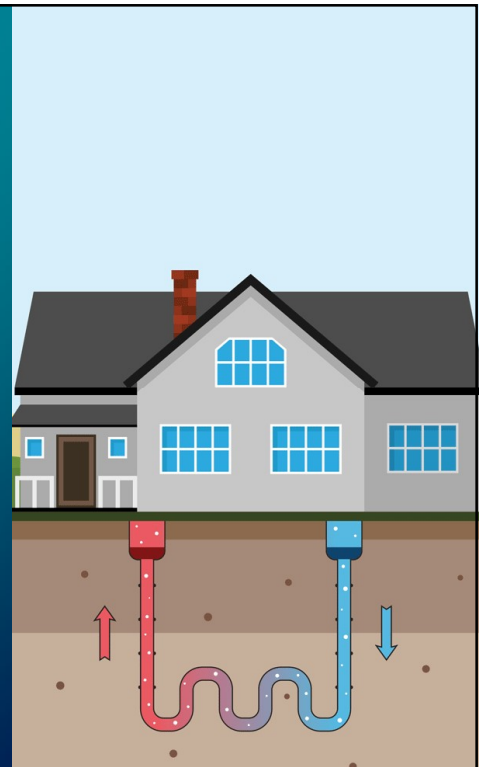

• Introduction

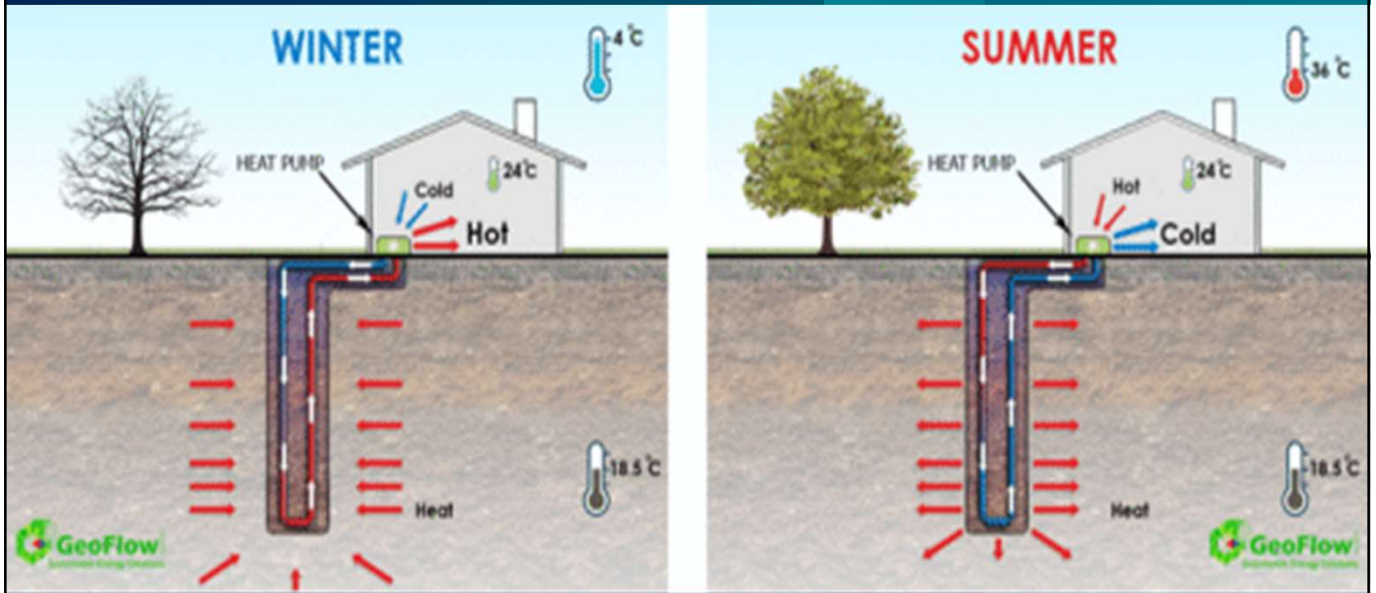

• Horizontal or vertical collectors?

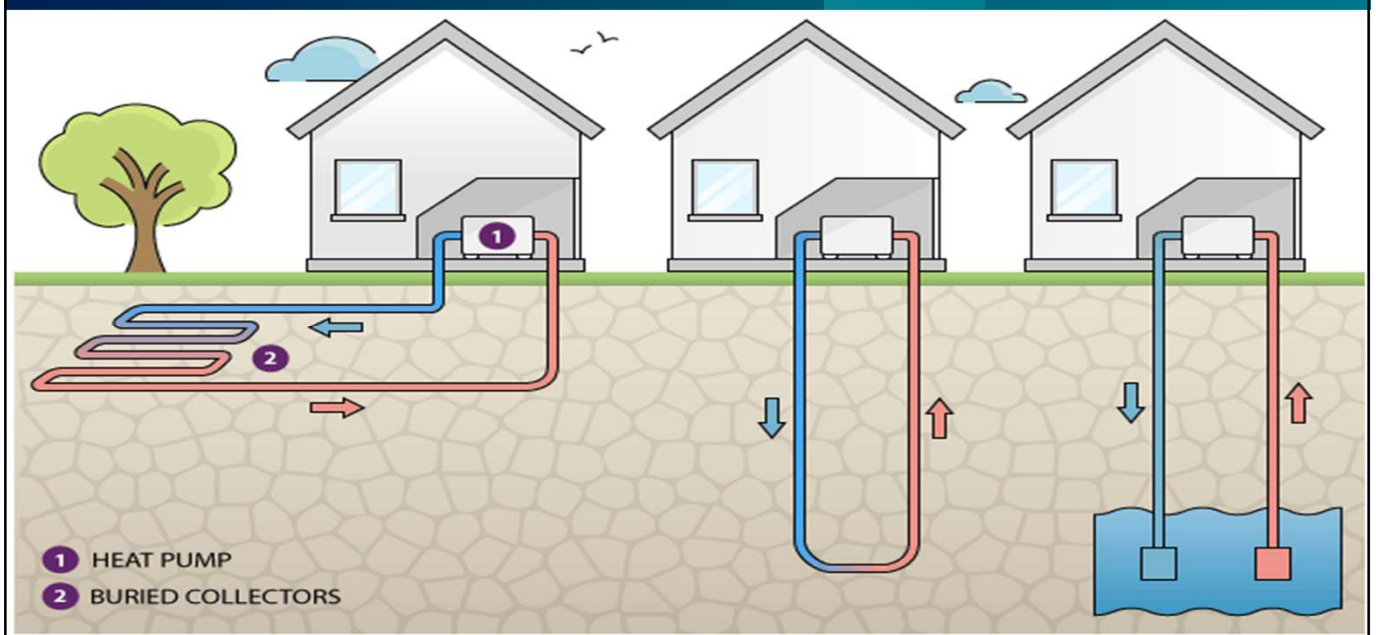

## Why Improve Geothermal Heat Pump Efficiency?

### Global Energy Challenge

Rising energy costs and environmental concerns drive demand for renewable solutions.

### GHPs as a Sustainable Solution

High efficiency and potential to reduce CO<sub>2</sub> emissions by up to 80%.

### Research Gap & Objective

- Accumulation the heat around geothermal heat exchanger pipes
- Lack of optimal soil mixtures for improved thermal conductivity and reduced resistance.

## Experimental Procedure



### Step 1 Excavation

Dig a hole in the soil to a depth of 2 meters using hand-held digging tools.



### Step 2 Soil Mix Preparation

**2.1 Grain Grading Test**

- Ensure proper grain gradation to improve heat transfer.
- Equation for Coefficient of Uniformity (Cu):
  - Good grain gradation:  $Cu > 5$
  - Poor grain gradation:  $Cu < 5$

**2.2 Soil Mixture Composition**

- Lenticular sand (crushers 12%) – 66%
- Sand construction waste – 34%
- Total volume of mixture: 1.4 m<sup>3</sup>



### Step 3 Base Layer Placement

- Place 30 cm of improved soil mixture at the bottom of the hole.
- Level the surface for pipe installation.

## Experimental Procedure



### Step 4 Pipe Installation

Lay the pipe in a horizontal spiral configuration at the bottom of the hole.



### Step 5 Sensor Placement

Install three temperature sensors in the soil between the pipes at different points along the hole, at a depth of 2 meters.



### Step 6 Covering and Backfilling

- Cover the pipe with 40 cm of improved soil mixture.
- Backfill the rest of the hole with ordinary soil.
- A closed-loop circulation system was set up, connected to a 500-liter insulated water tank located 6 m above ground.

## • Grain gradient analysis for samples

**Objective:** Evaluate how soil grain gradation affects thermal performance.

### Key Findings:

- Well-graded soil ( $C_u = 10$ ) shows better thermal conductivity due to fewer air voids.
- Poorly graded soil ( $C_u = 6.7$ ) has higher thermal resistance despite higher density.

**Conclusion:** Higher  $C_u$  values indicate better thermal performance; density alone is not a reliable predictor.

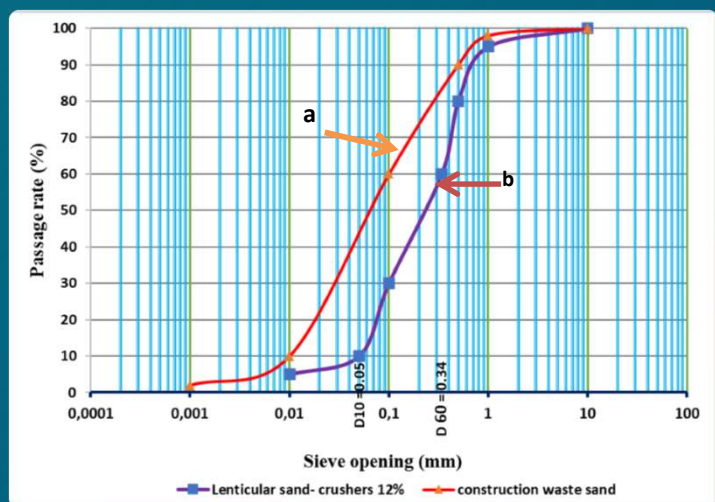

# Thermal analysis for experiments results

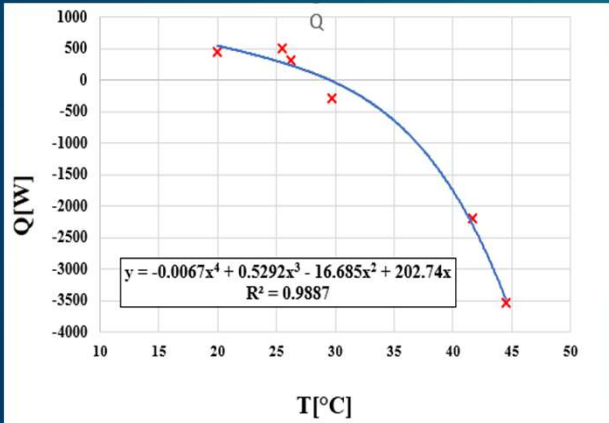

**Heat Absorption** (20–26 °C): System absorbed 326–513 W from soil → effective for heating applications.

**Equilibrium** (~29–30 °C): Heat exchange ≈ 0 W → indicates stable soil–fluid balance, prevents oversaturation.

**Heat Rejection** (>30 °C): Strong heat dissipation, reaching –3536 W at 44.5 °C → beneficial for cooling/industrial uses.

**Predictive Model:** A 4th-order polynomial regression accurately represents the nonlinear relationship between inlet temperature ( $T_i$ ) and exchanged heat ( $Q$ ).

# Conclusion

The engineered soil mixture improves geothermal heat pump efficiency by enhancing heat absorption and rejection, while also reducing ground heat accumulation. A predictive polynomial model was developed to optimize system design and long-term performance.

## Three most important topics

Enhanced Performance

System Stability

Predictive Modeling

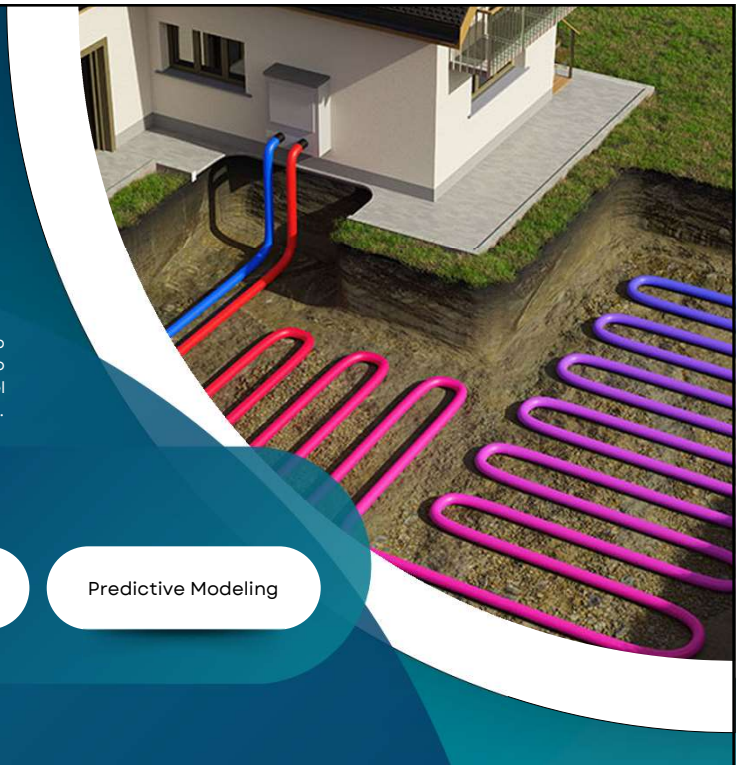

# Application

- Residential Applications
  1. Space heating and cooling for homes
  2. Domestic hot water production
- Agricultural Applications

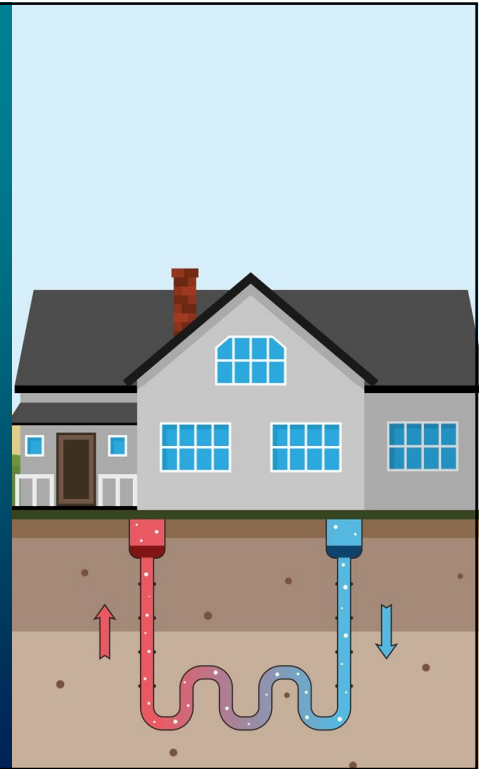

# Application

- Agricultural Applications
  1. Greenhouse heating
  2. Domestic hot water production

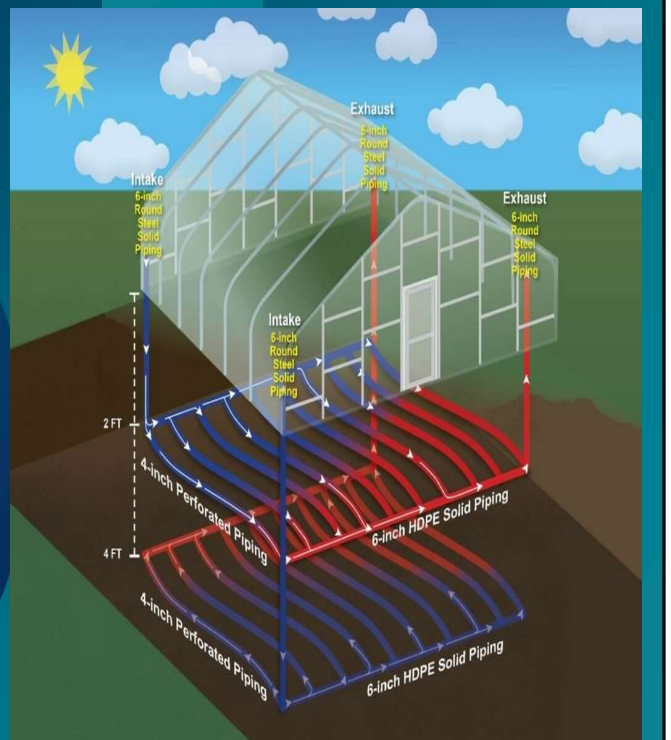

# Thank You For Your Attention!

**Setting up: Salman Brbhan,  
PhD Student**

Institute of Energy Engineering and Chemical Machinery,  
Faculty of Mechanical Engineering and Informatics,  
University of Miskolc, Hungary



AUGUST 26-28, 2022  
EUROPE  
MISKOLC, HUNGARY

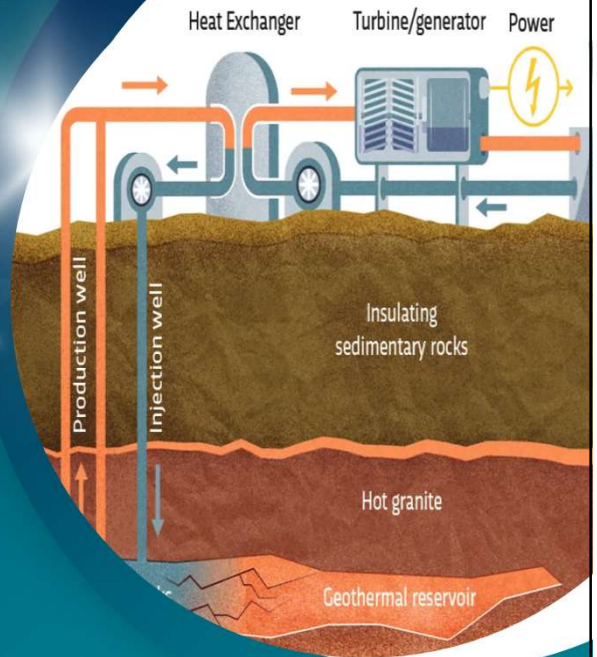

## Transforming Local Food Systems Using Urban Agriculture for Better Nutrition Outcomes



Xolile Mkhize (PhD) \*, Carin Napier (PhD), Kevin Jan Duffy (PhD), Wilna Oldewage-Theron (PhD)

Mangosuthu University of Technology, University of Auckland, University of KwaZulu-Natal,

University of Free State



**MUT** MANGOSUTHU  
UNIVERSITY OF TECHNOLOGY

## INTRODUCTION

Urban food and nutrition insecurity continues to expose systemic weaknesses and knowledge gaps within local food systems, severely restricting vulnerable communities' access to affordable and nutritious foods.



## What does our food system look like?



- Inequality**
- Climate change**
- Corporate dominance**
- Small-holder farmer exclusion**

**MANGOSUTHU**  
UNIVERSITY OF TECHNOLOGY

## Drivers of Global Food Trends

### Global Megatrends Impacting Industries and Consumers



**Building a Sustainable Future**

The health of the planet and impact of climate change continues to top the list of global concerns for governments, industries and consumers.



**Continued Technological Disruption**

The speed of technological innovation is constantly changing how we live and our economic and social structures. It is also a route to solving global issues.



**Demographic and Social Shifts**

Changes in fertility rates and age distribution in some key markets are influencing economies and marketing approaches, while social factors and changing household structures.



**Economic and Political Volatility**

We are living through a phase of economic and political volatility impacted by conflict and recovery from the pandemic. BRIC markets are challenging the previous economic status quo.



**Focus on Health and Wellbeing**

The global cost of healthcare is creating a more proactive approach both to health and wellbeing. The integration of tech is shaping how the markets develop.

**MUT** MANGOSUTHU  
UNIVERSITY OF TECHNOLOGY

Miskolc, 2025

327

**Health & Wellness**

**Plant-based and protein alternatives**

**Sustainability**

**Culinary exploration**

**Technology integration**

**MANGOSUTHU**  
UNIVERSITY OF TECHNOLOGY

**A FOOD SYSTEMS APPROACH- PATHWAYS & GLOBAL STRATEGIC FRAMEWORK**

**Transforming Food Systems: Pathways for Country-led Innovation**  
WHITE PAPER  
JANUARY 2022

Food and Agriculture Organization of the United Nations  
WORLD ECONOMIC FORUM

**BETTER PRODUCTION**

**BETTER NUTRITION**

**BETTER ENVIRONMENT**

**BETTER LIFE**

**MUT MANGOSUTHU**  
UNIVERSITY OF TECHNOLOGY

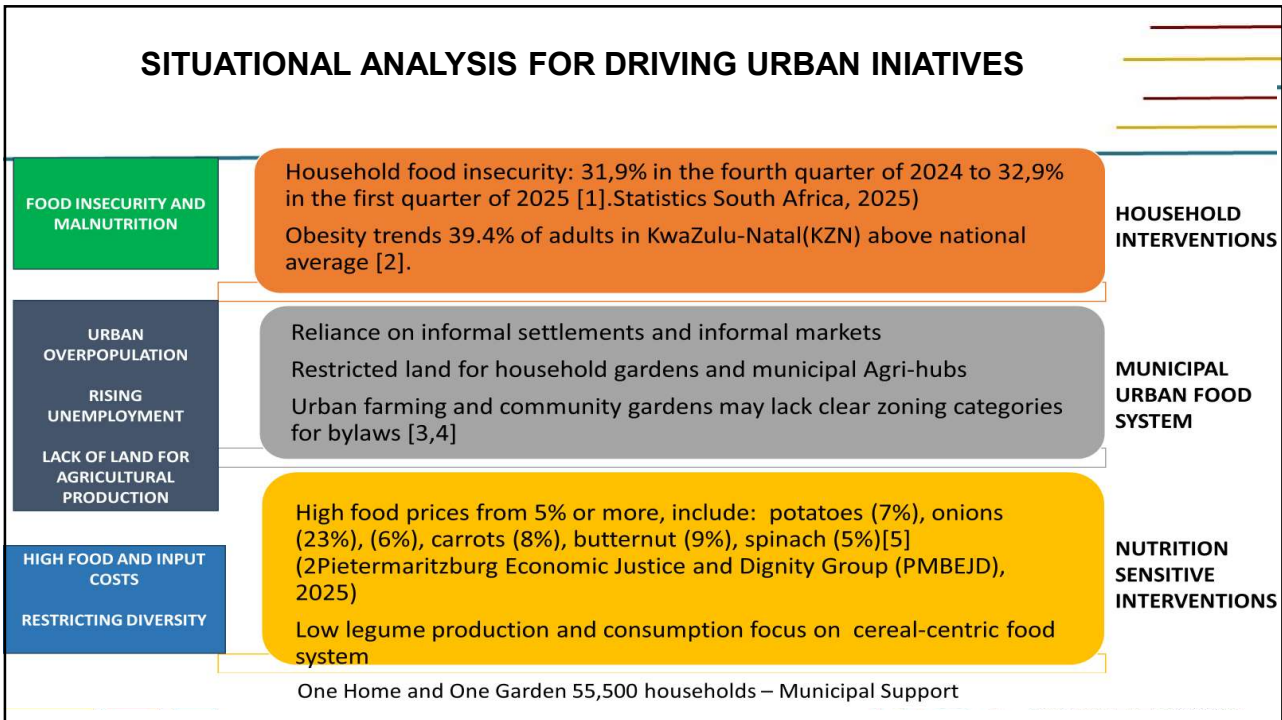
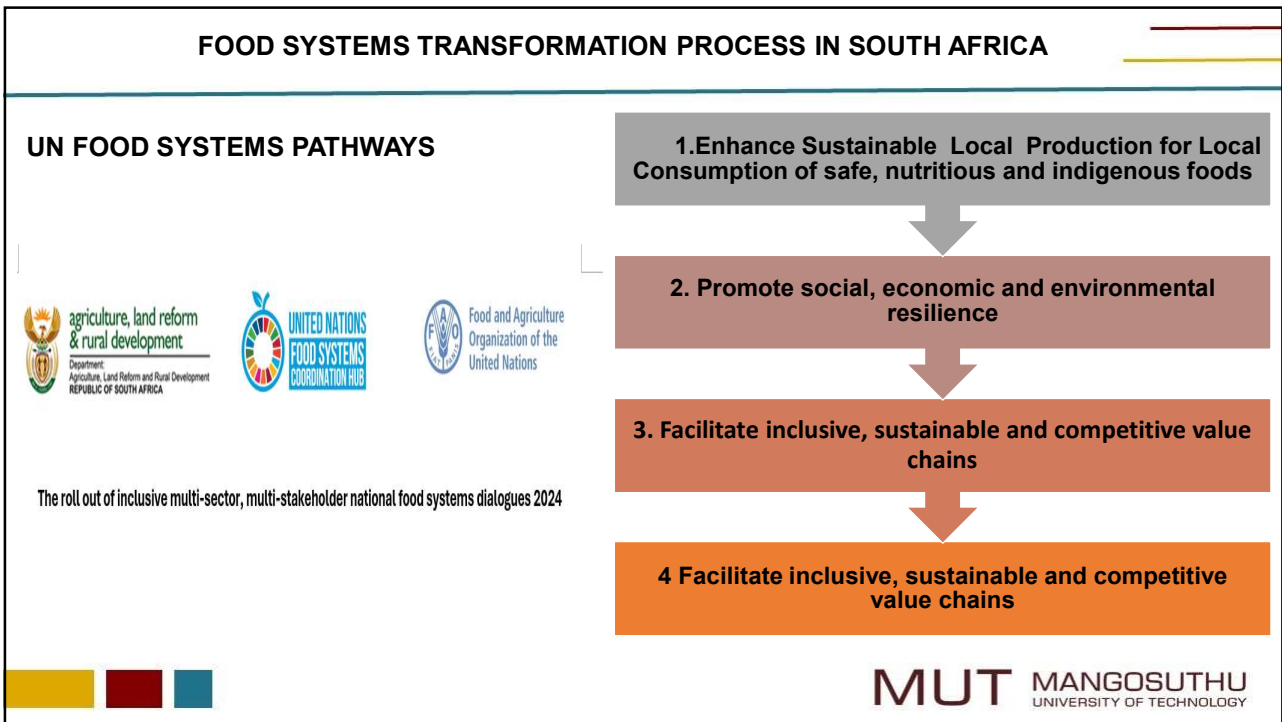

## AIM OF THE STUDY

This interventional study aimed to promote diverse grain legume production and consumption through hands-on training, fostering nutrition-sensitive and sustainable practices within an urban agricultural hub to improve food and nutrition security.

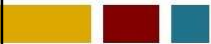

## STUDY AREA

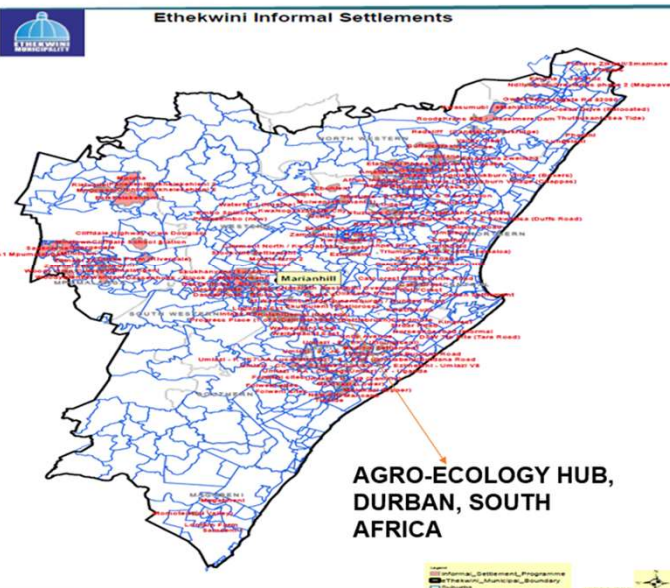

### PRODUCTION

Grain legumes used were:  
Phaseolus vulgaris L., Cicer arietinum, Phaseolus vulgaris, Vigna radiate, Vigna unguiculata and Vigna subterranean.

### DEMONSTRATION PLOT

### FARMER PLOT

### CONSUMPTION

South African Guidelines for Healthy Eating

Farmers had to consume 125 g, or ½ a cup, of legumes per portion 3–5 times a week

### INCREASED LEGUME INTAKE



## METHODOLOGY

A cross-sectional, mixed-methods study using purposive sampling was conducted with 103 participants, divided into an experimental group (n=53) and a control group (n=50). Data collected included legume yields and dietary intake.

Grain legume trials were conducted using a Randomized Complete Block Design (RCBD). Yields (Trial 1, then Trial 2), were analyzed with SPSS (v25.0) using ANOVA, Food Finder software, and Wilcoxon tests.

## RESULTS

### LEGUME PRODUCTION PERFORMANCE ON FARMER PLOTS

**Table 1. Production limitations transitioning to legume diversification**

Limitations	Level of Limitations (%)		P-value
	Year 1	Year 2	
Growing legumes at a time scheduled for the project	28.0	18.8	0.065
Limited water supply	83.0	75.4	0.337
Soil infertility	9.4	5.6	0.459
Forgetting training information	18.8	9.4	0.166
Limited land area for cultivation	39.6	33.9	0.544
Theft of supplied seeds	1.8	5.6	0.302
Dry season	24.5	84.9	0.000
Pest infestation and control	83.0	75.4	0.337

**Table 2. Yields of grain legume varieties (kg ha<sup>-1</sup>) in Trial 1 and Trial 2**

Legume variety ▼	Number of farmers planting each variety	Trial 1	Trial 2
		Mean yield kg ha <sup>-1</sup> (means ±SE <sup>1</sup> )	Mean yield kg ha <sup>-1</sup> (means ±SE <sup>1</sup> )
<b>Chickpeas</b> <i>Cicer arietinum</i>	53	41.41±19.46	36.60±17.46
<b>Butter beans</b> <i>Phaseolus vulgaris L</i>	53	80.75±27.23	93.30±24.51
<b>Red kidney beans</b> <i>Phaseolus vulgaris L</i>	53	141.60±22.27	123.39±22.58
<b>Cow peas</b> <i>Vigna unguiculata</i>	53	74.25±19.45	61.88±15.87
<b>Green moong beans</b> <i>Vigna radiate</i>	53	1.13±1.13	1.13±1.13
<b>Jugo beans</b> <i>Vigna subterranea</i>	53	74.91±19.28	70.28±20.53

Grain legume varieties differed significantly ( $p = 0.001$ ) in their performance in terms of grain yields. The highest yield was achieved with **red kidney beans (141.60 kg ha<sup>-1</sup>)**, followed by white broad beans (80.75 kg ha<sup>-1</sup>), **jugo beans (74.90 kg ha<sup>-1</sup>)**, and chickpeas (41.41–60 kg ha<sup>-1</sup>).

Higher Protein Contribution **Jugo Beans**  
24-26% [6]

**Table 3. Legume Yield by Gender: Comparison of Trial 1 and Trial 2**

Legume variety groups	Gender frequency	Field Trial 1		Field Trial 2	
		Mean per gender	Std. Deviation	Mean per gender	Std. Deviation
<b>Men</b>	84	33.63	77.95	49.10	90.63
<b>Women</b>	234	81.70	166.40	69.93	154.13
<b>Total</b>	318	69.00	149.64		140.34

Female farmers significantly outperformed males in legume production ( $p = 0.012$  vs.  $p = 0.244$ ), underscoring gender as a key factor in productivity

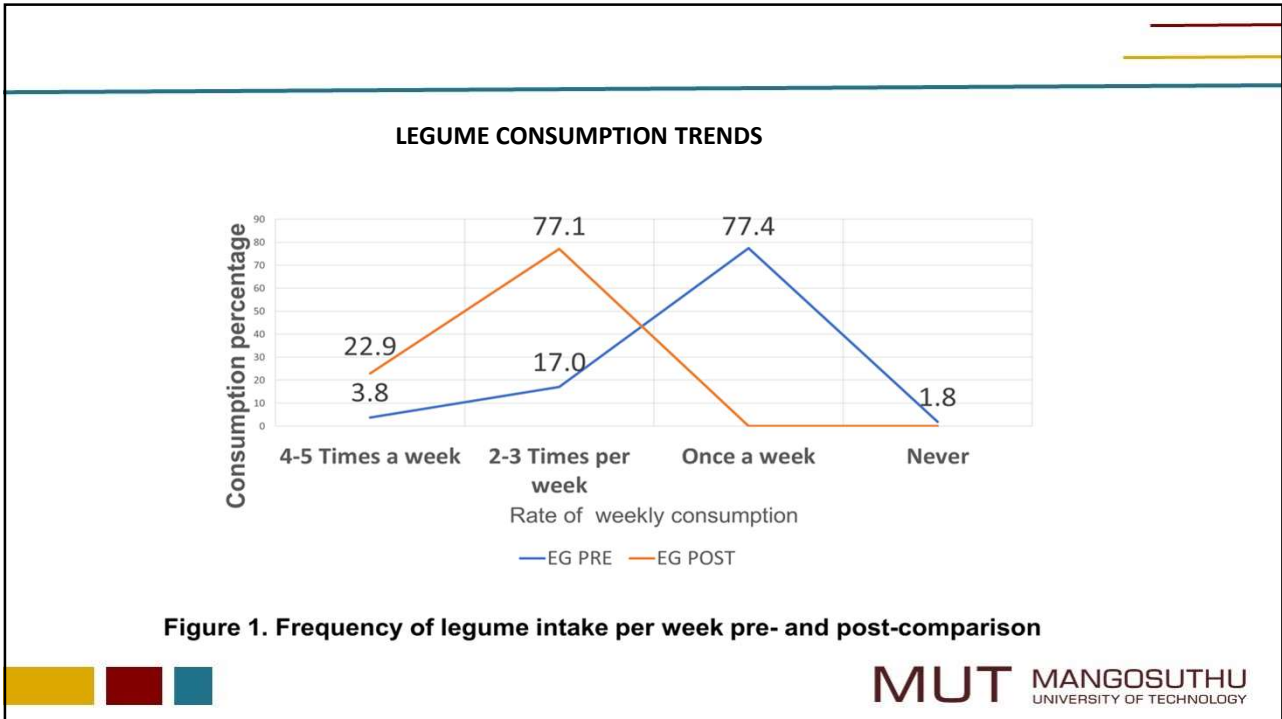

### Table 4. Dietary Diversity Scores: Pre- and Post Intervention

Food Groups	Mean FGDS	± SD	Ranges	Mean FGDS	± SD	Ranges	Significance	Notable Shift
EG	Pre-inter. EG (n=53)			Post-inter. EG (n=35)			p-value	
Meat	6.5	3.07	1-4	6.1	2.92	1-4	0.540	EG significantly increased legume consumption (p= 0.001)
Eggs	1	0.00	0-1	1	0.00	0-1	1.000	
Dairy	4.3	2.18	1-9	3.3	2.30	1-9	0.045	
Cereals	9.6	3.67	1-5	7.3	4.05	1-5	0.009	
<b>Legumes</b>	<b>2.4</b>	1.35	1-7	<b>5.7</b>	2.56	1-7	<b>0.001</b>	
Vitamin A-rich fruits & Vegetables	5.0	1.80	1-8	3.8	1.88	1-8	0.004	
Other Fruits	5.3	4.02	1-19	5.0	2.81	1-19	0.681	
Other Vegetables	6.6	2.28	1-16	6.1	3.10	1-16	0.416	
Fat and Oils	2.1	0.90	1-5	1.8	0.59	1-5	0.062	
FVS	42.8	±18.90	23-74	40.1	±20.21	23- 74	0.531	
DDS	8.59	±0.74		8.23	±1.11		0.097	
Food Groups	Mean FGDS	±SD	Ranges	Mean FGDS	±SD	Ranges		CG lowering meat consumption significantly (p= 0.001) whilst also dropping legume intake
CG	Pre-inter. CG (n=50)			Post- inter. CG (n=44)				
Meat	7.2	1.30	1-4	5.3	2.9	1-4	0.001	
Eggs	1	0.00	0-1	1.0	0.0	1-1	1.000	
Dairy	8.0	3.82	1-9	3.0	1.7	1-9	0.001	
Cereals	13.0	8.62	2-5	8.8	3.0	1-5	0.002	
<b>Legumes</b>	<b>3.0</b>	1.82	1-8	<b>2.0</b>	1.2	1-7	<b>0.003</b>	
Vitamin A-rich fruits & Vegetables	6.0	4.52	1-8	4.3	0.9	1-8	0.010	
Other Fruits	12.0	6.97	1-19	4.6	2.2	1-19	0.001	
Other Vegetables	10.0	6.72	1-16	5.2	2.3	1-16	0.001	
Fat and Oils	3.0	2.04	1-5	2.2	0.7	1-5	0.011	
FVS	63.2	±35.81	23-75	36.4	±14.9	20-74	0.001	
DDS	8.69	0.89		8.52	0.98		0.412	

## CONCLUSIONS AND RECOMMENDATIONS

- Integrating legumes into farming systems **promoted diversification**, while the active involvement of **women in urban agriculture** enhanced both **production and nutrition outcomes**.
- Urban farming interventions should promote balanced diets and **include follow-up surveys**, as **participants may focus on project-specific crops** while **neglecting other essential food groups**, risking nutritional imbalances.
- Agricultural hubs must adopt efficient urban farming techniques and **establish resilient legume seed banks** in response to **climate change challenges**.
- Policy must **prioritize legume seed incentives and diversify offerings**, as farmers often receive only a **single seed variety**, making **legumes costly and largely inaccessible**, which **discourages their adoption in production systems**.

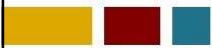

## ACKNOWLEDGMENTS

- The MUT Research Directorate for funding the research.
- eThekweni Municipality and Agrihub team
- Farmer group organisation, including the women's group



## REFERENCES

1. STATSSA. 2025. Statistics South Africa on Quarterly Labour Force Survey (QLFS) – Q1: 2025. <https://www.gov.za/news/media-statements/statistics-south-africa-quarterly-labour-force-survey-qlfs-%E2%80%93-q1-2025-13-may?utm>.
2. Human Sciences Research Council (HSRC). (2023). Nearly 50% of South African adults are overweight or obese. HSRC News. Retrieved August 2025, from <https://www.hsrc.ac.za/news/research-outputs/almost-50-of-adult-south-africans-are-overweight-or-obese-poverty-and-poor-nutrition-are-largely-to-blame>
3. Harper, A.J.et al. 2022. Dietary diversity, food insecurity and the double burden of malnutrition among children, adolescents and adults in South Africa: Findings from a national survey. Public Health 10:948090. doi: 10.3389/fpubh.2022.948090
4. Wegerif, MC.A. 2024. Street traders' contribution to food security: lessons from fresh produce traders' experiences in South Africa during Covid-19. Food Security (2024) 16:115–131 <https://doi.org/10.1007/s12571-023-01409-w6>.
5. . PMBEJD. (2025, May & June). Household Affordability Index – April & May 2025. May 2025: <https://za.boell.org/en/2025/06/02/may-2025-household-affordability-index-and-key-data>
6. SAMRC. 2024. Food composition tables for South Africa Cape Town2024 :[Available from: <https://www.mrc.ac.za> ]





**Co-Design Circles as Vehicle for Climate Change  
Adaptation:  
A Case Study of Climate-Smart Agricultural School  
Garden in Umlazi, South Africa**

Nkonki-Mandleni, B.; Ighodaro, ID; Hlungwani, C.  
Email: [mandleni@mut.ac.za](mailto:mandleni@mut.ac.za)

EWFC 2025 Summit, University of Miskolc, Hungary  
27 August 2025



## Background

As part of the transformation agenda, universities in South Africa have a developmental agenda to address **social injustices** caused by the apartheid era i.e. poverty, inequality, unemployment, poorly located infrastructure, health, uneven and even poor public services and the divided South Africa (National Development Plan 2030);

The National Plan on Higher Education (2001) provides a complete case for universities to play a role in the national efforts to advance social justice by being **active partners** with communities in their quest to find solutions.

The South African Higher Education White Paper on Transformation (DoE,1997) identified **community engagement** (CE) as one of the multiple purposes for higher education.

The 2013 White paper for Post School Education and Training (DHET, 2013) asserts that CE in its various forms i.e. socially responsive research, partnerships, learning that engages communities has become **integral part of the work of the university**..... i.e. a scholarship of engagement.



## Background - Scholarship of Engagement

Scholarship of Engagement (SoE) is a true academic posture, rooted in values of social justice and citizenship for academics to work in ways that build mutually beneficial bridges between university and external communities (Beaulieu, Brenton and Brouselle, 2018).

SoE is about advancing both the university's core functions and social benefits and partnerships for co-creation and application of knowledge between universities and external communities (Fongwa *et al.* 2022).

Major emphasis here is the creation of a space for **active participation of community stakeholders** in the conceptualisation and execution of research to the dissemination of research findings i.e. engaged research.



## Context

- The project is part of the international project on co-designs of climate smart Indigenous and traditional food gardens in primary schools in three South African ecoregions in KwaZulu-Natal, Gauteng (UJ collaboration), and Limpopo (University of Limpopo collaboration)
- It enhances social protection by addressing climate change risks in food insecurity; child health risks and risks from water-related hazards to food production.
- It situates participation in schools-based climate smart gardening practices to foster climate responsive communities while building intergenerational climate literacy that brings interdisciplinary agricultural and climate science knowledge together with Indigenous and Local Ecological Knowledges (ILEK).
- The project assembles interdisciplinary researchers from South Africa, Canada and U.S.A with diverse expertise.

## Context

### Unprecedented weather patterns:

- Excessive floods
- Extreme heat waves
- Disruption in agriculture production
- Child malnutrition
- Intergenerational climate illiteracy



## Problem

- Climate change continues to pose significant threats to food security, child health, and sustainable community development, particularly in socio-economically marginalized regions.
- Direct impact on hunger (SDG 2), health (SDG 3), and communities (SDG 11).
- Intergenerational climate literacy is becoming extinct
- Interdisciplinary climate literacy is a challenge
- Child malnutrition is prevalent (UNICEF, 2025)

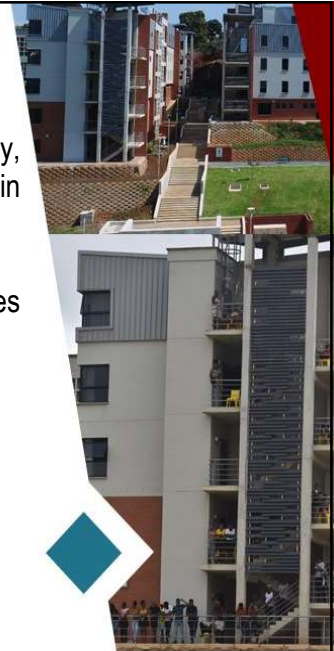

## Aim & Objectives

### Study Aim:

To explore the potential of co-design circles as participatory vehicles for climate change adaptation in the urban township of Umlazi, KwaZulu-Natal, South Africa to positively impact children's climate literacy, nutrition, and land relations.

### Specific objectives:

To align with SDG 13 (Climate Action) and AU Agenda 2063 in:

- Co-creating sustainable, culturally responsive school gardening practices.
- Increase intergenerational and interdisciplinary climate literacy.
- Scale a model for trans-sectoral, community-based adaptation strategies.



**MUT** MANGOSUTHU  
UNIVERSITY OF TECHNOLOGY

## Overview: What is a co-design circle?

- A co-design circle is the terminology we are using to describe our community co-design process.
- It is a solidarity-driven, participatory research method that brings people together from various backgrounds to collaborate as equals in understanding problems and designing solutions
- Co-design is built on respect for each participant's knowledge, experiences, and cultural values, with the intention of ensuring the design process reflects community needs and aspirations.

**MUT** MANGOSUTHU  
UNIVERSITY OF TECHNOLOGY

## Literature Review: Climate Change, Child Nutrition, and Adaptation Strategies

**Rising Malnutrition:** Climate change is projected to increase the number of malnourished children in Africa from 33M (baseline) to 42M by 2030 and 52M by 2050 (Temesgen et al., 2024; Husen & Temesgen, 2022).

**Vulnerable Communities:** Children in socio-economically vulnerable rural and urban South African areas face severe food insecurity due to climate impacts (IPCC, 2022).

**Local Climate Impacts:** KwaZulu-Natal province in SA is already experiencing extreme heat and floods that negatively affect agriculture and child nutrition.

There is urgent need for enhanced climate resilience strategies in the province (The South African Environmental Observation Network (NRF-SAEON, 2025)

**Adaptation Practices:** Agroecology and indigenous practices have shown positive food security outcomes (Zazu & Manderson, 2021; Nwaogu, 2021).



## Literature Review: Cont'd

**Knowledge Integration Gaps:** Limited integration of community knowledge with climate science persists (Apraku et al., 2021; Ziervogel et al., 2022).

**Call for Inclusive Solutions:** Emphasis on community-based, culturally responsive strategies that integrate Indigenous & Local Ecological Knowledge (ILEK).

**Study Relevance:** This study focuses on co-design circles in Umlazi to support local adaptation and nutrition resilience.



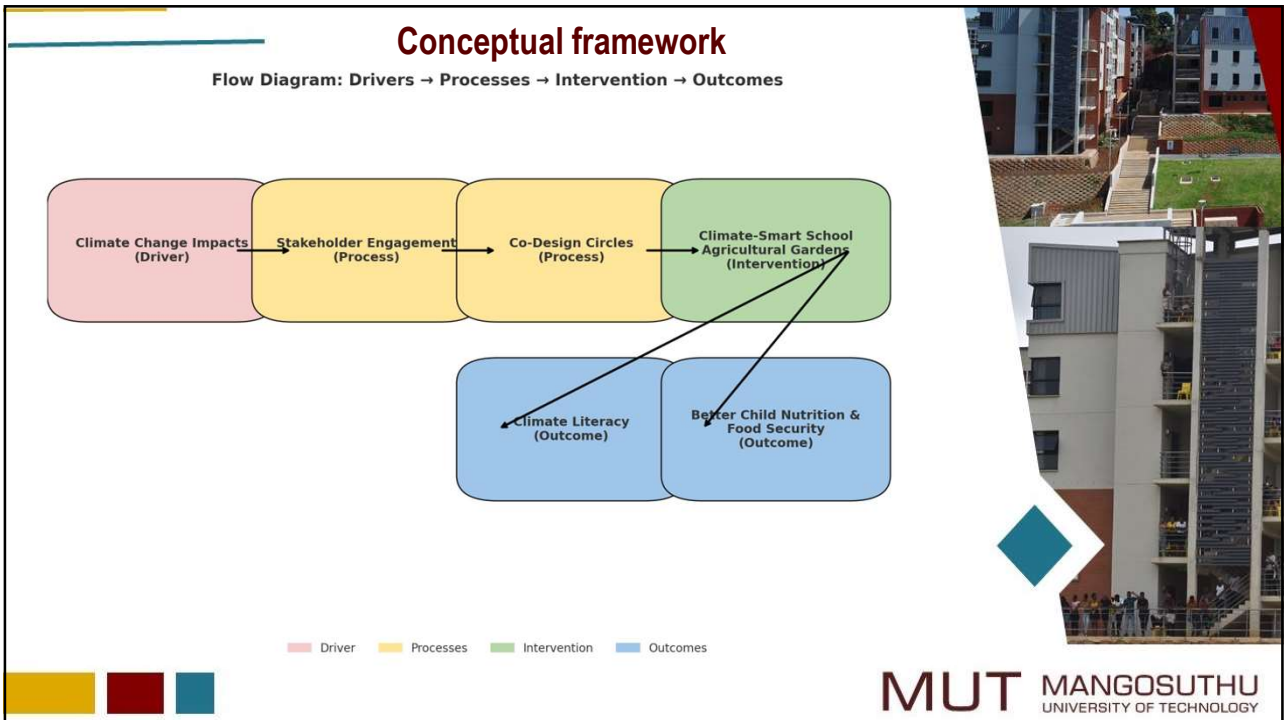
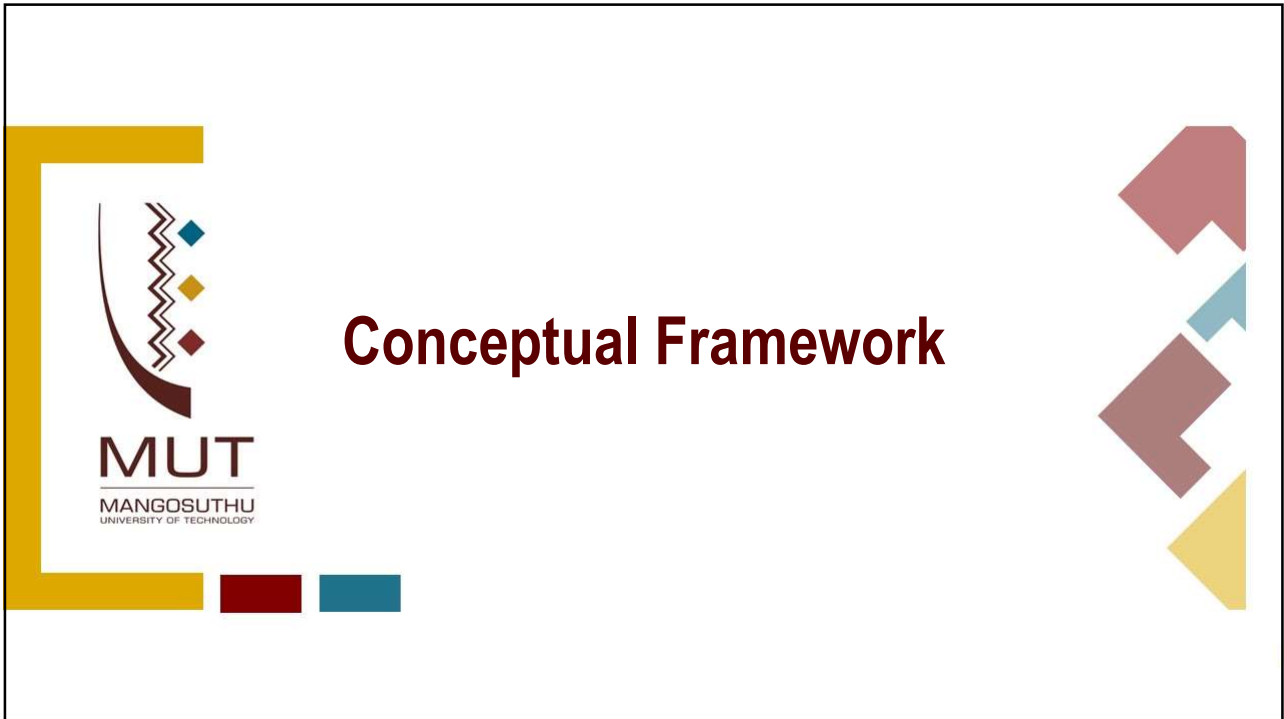

## Methodology

**Approach:** Participatory action research.

**Sampling:** Elements of sampling unit were total of 75 participants i.e. 60 Grade 1 learners, their parents, schoolteachers, the school governing body, 3 civil society organisations i.e. organised youth, ILEK keepers and one NGO.

The selection was based on the fact that the population in the areas of study was negatively affected by climate change effects.

**Data collection procedure:** Permission, Ethical clearance, Arrangements with school to carry out design circles to selected participants, Suitable times were arranged with participants.

**Co-design:** Collaborative creation of Indigenous food gardens & planting calendars.

**Collaboration:** Interdisciplinary team from South Africa, Canada, USA.





### Findings

- Inclusive participation enabled knowledge sharing
- Active participation facilitated co-learning.
- Improved climate literacy.
- Co-design circles facilitated the development of a localized planting calendar.
- Promotion of culturally responsive gardening.



## Discussions

- Co-design integrates Indigenous and scientific knowledge.
- Fosters intergenerational learning and community ownership.
- Empowers communities.
- Supports transformative adaptation.
- Supports capacity building and context-specific solutions.
- **Challenges:** Sustaining long-term engagement and assessing long-term impact.



**MUT** MANGOSUTHU  
UNIVERSITY OF TECHNOLOGY

## Conclusion & Recommendations



## Conclusion

- The design circle provided platform for universities and communities to meet to address social challenges.
- Through the design circle the university (MUT) has been able to deliver on its developmental agenda.
- Co-design circles have proved to be active partnerships that assist communities to find solutions to climate change challenge
- Co-design circles promote collaborative problem-solving, inclusive and culturally rooted solutions among diverse stakeholders.
- Interdisciplinary approach holds promise for enhancing adaptive capacity and resilience among vulnerable communities.
- Communities are empowered to take ownership of solutions to climate change challenge that promote holistic sustainable solutions

## Recommendations

- Need to explore scalability and long-term outcomes.
- Useful model that universities could use to address social injustices.

### Acknowledgements:

- National Research Foundation
- Office of the VC & Principal: Professor Sibiya
- Office of the DVC: Dr Mienie
- Co-researchers: Dr Ighodaro and Dr Hlungwani (MUT)
- Research collaborators and co-Pis – Professor Fikile Nxumalo, University of Toronto and Professor Madkins, University of Austin Texan.



Thank you  
Siyabonga!

A RESEARCH-INFORMED UNIVERSITY

EXCELLENCE IN TEACHING AND LEARNING

FAIR AND INCLUSIVE

THANK YOU

ACCOUNTABILITY  
INTEGRITY  
RESPECT  
EXCELLENCE

**MUT**  
MANGOSUTHU  
UNIVERSITY OF TECHNOLOGY

## Spatial and temporal changes on the fate and bioavailability of Se: Is this Medical Geology?

**Adebayo S. Solanke, PhD**

Chemist III

Florida Department of Agriculture and Consumer Services

**\*Michael Martínez-Colón, PhD**

Associate Professor

School of the Environment

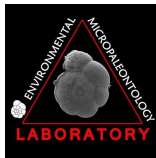

\*[michael.martinez@famu.edu](mailto:michael.martinez@famu.edu)  
\*<http://www.foramlaboratory.com>



Bevezetés

Cél/Célkitűzések

Módszertan

Eredmények/Megbeszélés

Ajánlások

### What is a Potentially Toxic Element (PTE)?

A chemical element having the potential of becoming toxic in an ecosystem

(Davis et al., 1978; Pescod, 1992)



Bevezetés    Cél/Célkitűzések    Módszertan    Eredmények/Megbeszélés    Ajánlások

## What is Bioavailability?

“...fraction of a chemical accessible to an organism for absorption or as a measure of potential toxicity” (Natl. Research Council, 2003)

```

    graph TD
      MS[Metals Sorbed to Particles/Colloids] <--> M[M^{x+} (aq)]
      M <--> IMC[Inorganic Metal Complexes (e.g., chloride)]
      M <--> ORF[Oxidized or Reduced Forms]
      M <--> MOC[Metal Organic Complexes (e.g., proteins)]
      M <--> OMS[Organometallic Species (e.g., methyl)]
    
```

## What is Fractionation?

“The identification and quantification of the different sediment components in which a PTE occurs” (Tack and Verloo, 1995)

Bevezetés    Cél/Célkitűzések    Módszertan    Eredmények/Megbeszélés    Ajánlások

# MEDICAL GEOLOGY...

1960

202??

“...scientific discipline that examines the impacts that geologic materials and processes have on human and ecosystem health.”

Brusseau and Pepper (2019)

FLORIDA A&M UNIVERSITY  
SOPORTYUZZETDELMI ISKOLA

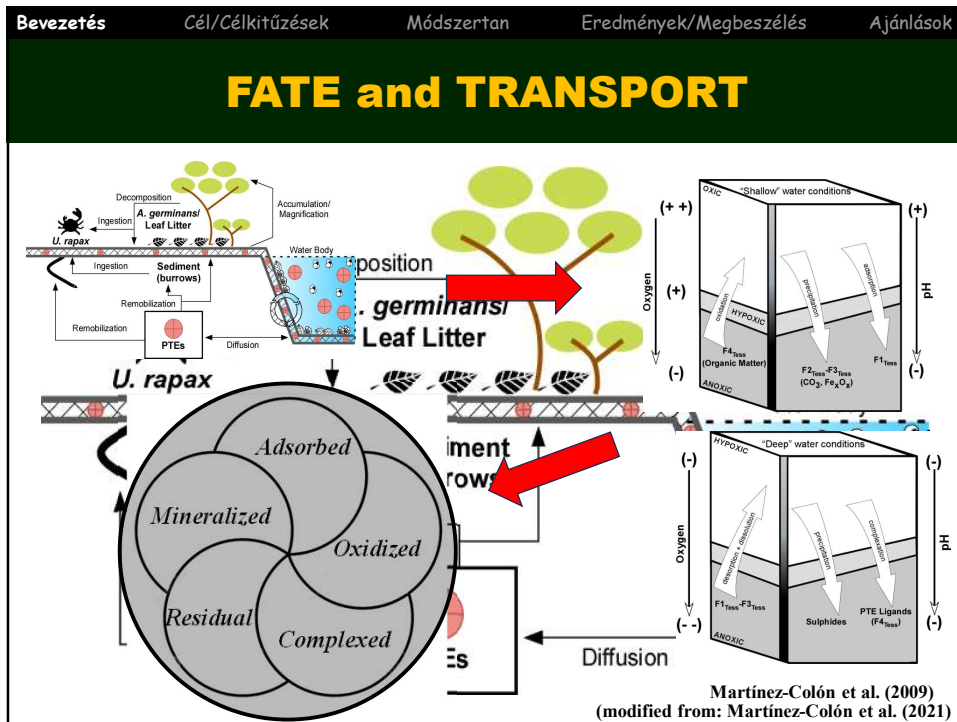

Bevezetés Cél/Célkitűzések Módszertan Eredmények/Megbeszélés Ajánlások

## PURPOSE

### Distribution and bioavailability of PTEs determined will be

#### OBJECTIVE #1

Evaluation of sediment contamination using sediment quality guidelines (SQG)

#### OBJECTIVE #2

Understanding of the distribution of PTEs from recent and sediment historical records

FLORIDA A&M UNIVERSITY  
SOPANYI ZSÉF DELEMISKOLA

Bevezetés    Cél/Célkitűzések    **Módszertan**    Eredmények/Megbeszélés    Ajánlások

## APALACHICOLA RIVER

Drainage basin of the Apalachicola River

Chattahoochee River sub-basin (CRsb)

Flint River sub-basin (FRsb)

The map shows the drainage basin of the Apalachicola River, which flows from the border of Alabama and Georgia into Florida. The Chattahoochee River sub-basin (CRsb) is outlined in yellow, and the Flint River sub-basin (FRsb) is outlined in red. FAMU is marked with a red diamond in Florida. The map also shows Apalachicola Bay and a 25 km scale bar.

FLORIDA A&M UNIVERSITY  
KÖRNYEZETVÉDELMI ISKOLA

Bevezetés    Cél/Célkitűzések    **Módszertan**    Eredmények/Megbeszélés    Ajánlások

## APALACHICOLA BAY

The map shows Apalachicola Bay with 11 sampling stations marked with black dots. Key geographical features include Lake Wimiko, Jackson River, Apalachicola River, St. Marks River, East River, Franklin, Shooting Range, St. Vincent Sound, St. Vincent Island, St. George Island, and Northern Gulf waters. Two red squares on the map indicate the locations of the two photographs on the right.

A researcher wearing a blue shirt and a white cap is on a boat, working with equipment in the water.

A researcher wearing a blue shirt and a white cap is on a boat, working with equipment in the water.

A small inset map shows the location of Apalachicola Bay on the Florida coast.

FLORIDA A&M UNIVERSITY  
KÖRNYEZETVÉDELMI ISKOLA

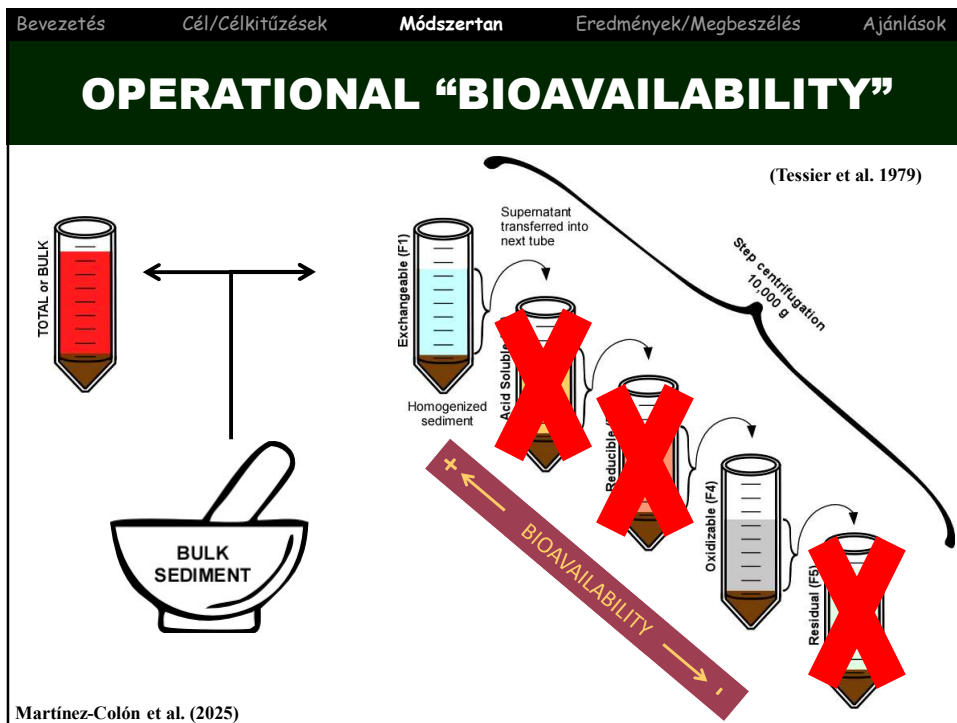
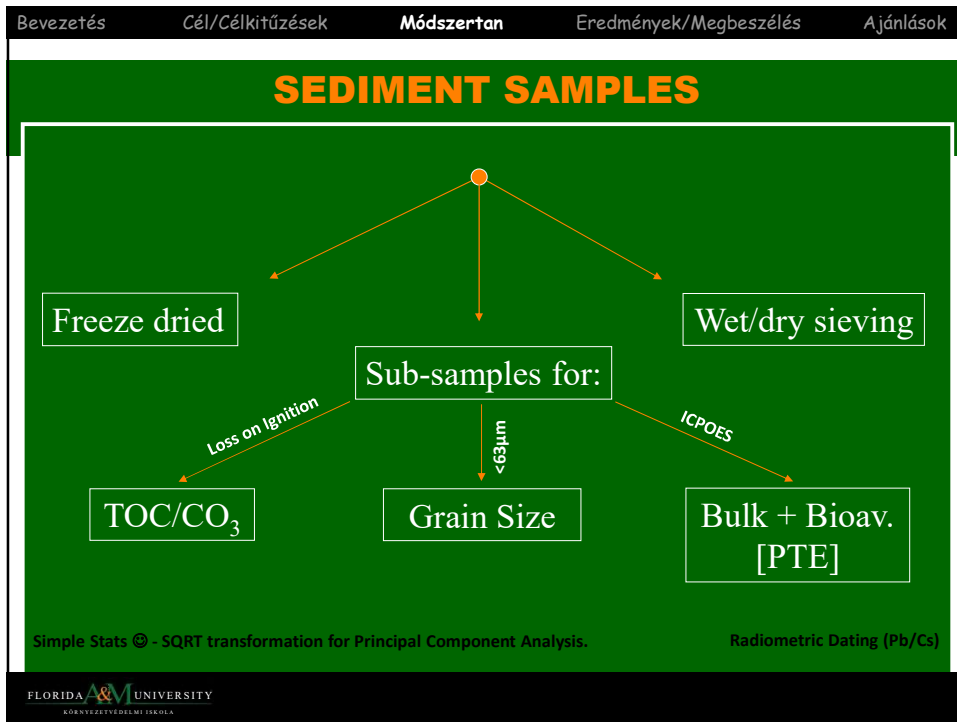

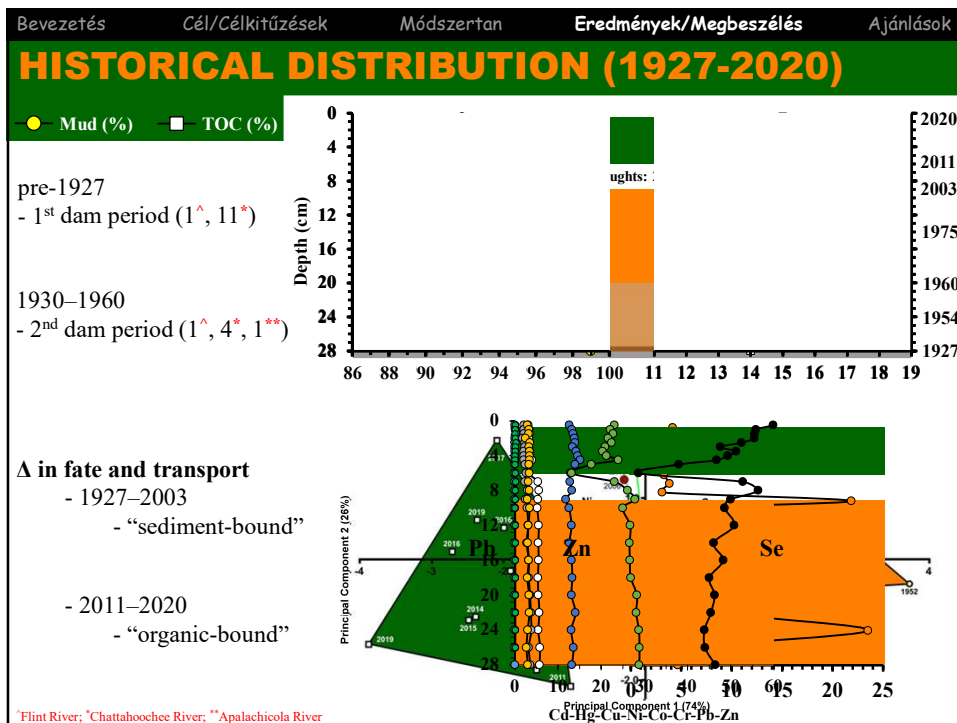
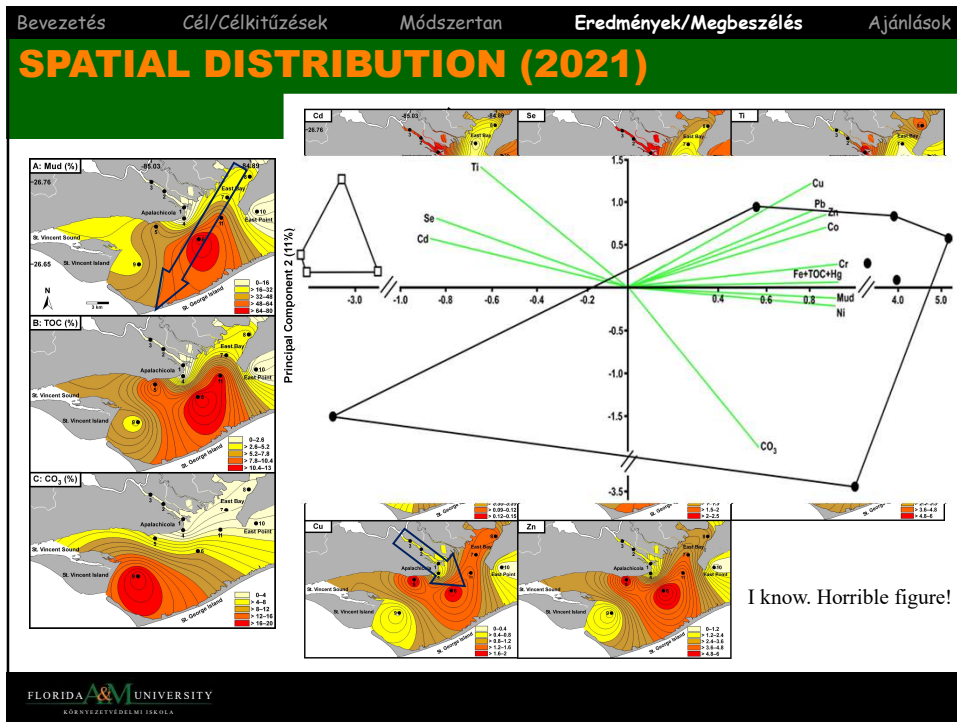

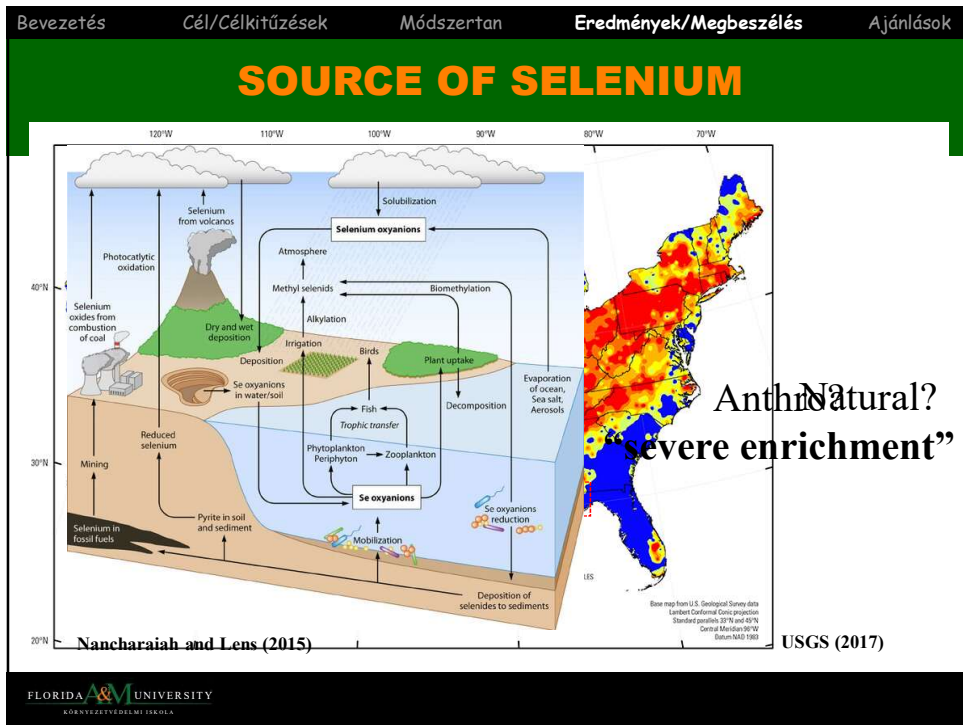

Bevezetés Cél/Célkitűzések Módszertan **Eredmények/Megbeszélés** Ajánlások

# IS THE BAY: CURRENTLY POLLUTED?

## Well... NO...DEPENDS

☹️

Based on Sediment Quality Guidelines:

FLORIDA A&M UNIVERSITY  
KÖRNYEZETVÉDELMI ISKOLA

Bevezetés Cél/Célkitűzések Módszertan Eredmények/Megbeszélés Ajánlások

**IS THE BAY:  
HISTORICALLY  
POLLUTED?**

**Well... NO...DEPENDS**  
☹️

Based on Sediment Quality Guidelines:

---

FLORIDA A&M UNIVERSITY  
KÖRNYEZETVÉDELMI ISKOLA

Bevezetés Cél/Célkitűzések Módszertan Eredmények/Megbeszélés Ajánlások

**IS THIS  
MEDICAL  
GEOLOGY?**

**Well... YES** 😊

Since 2011–2012, the rapid decline in the *Crassostrea virginica* landings has threatened the industry (Botta et al., 2020).

-  $2.5 \times 10^6$  to  $0.1 \times 10^6$  pounds of meat

FLORIDA A&M UNIVERSITY  
KÖRNYEZETVÉDELMI ISKOLA

# NO QUESTIONS...RIGHT?

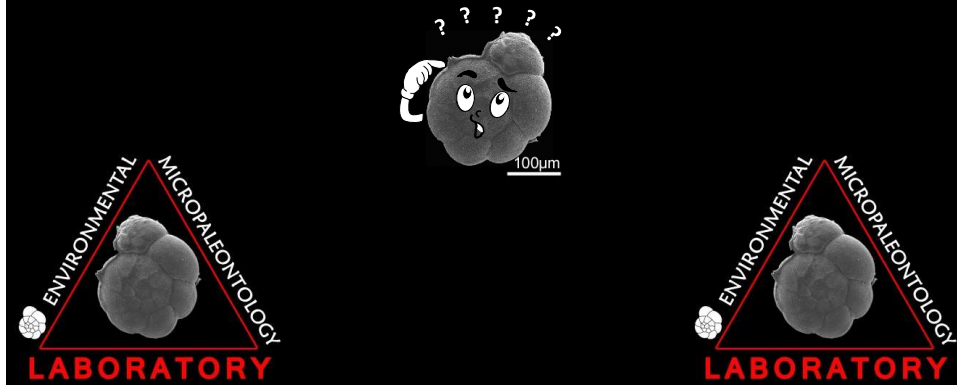



## THE ROLE OF FORESIGHT IN GOAL-ORIENTED TRANSFORMATIVE CHANGE PROCESSES

Attila Havas, CERS, Centre for Economic and Regional Studies & AIT, Austrian Institute of Technology  
K. Matthias Weber, AIT, Austrian Institute of Technology & Université Gustave Eiffel

*Energy-Water-Food-Climate-Nexus International Summit 2025,*  
26–28 August 2025, Miskolc



### MOTIVATION

Major challenges need to be tackled with concerted efforts

Goal-oriented transformative change processes require:

- considering a broad range of possible goals by key stakeholders
- selection of relevant, feasible, and ambitious goals
- strong commitment of the full spectrum of relevant actors to act

Hence, we need to consider

- the role of foresight (and other FLAs) in guiding and implementing GOTCs
- the relevance of various types of (extant, known) foresight (and other FLAs)
- the need for devising (piloting) new types of foresight (and other FLAs)

### GOAL-ORIENTED TRANSFORMATIVE CHANGE: A DEFINITION

A closely interrelated set of *radical changes* at the level of a *socio-technical or an entire socio-economic system*, with changes simultaneously affecting its underlying technologies, business models, cognitive frames, institutions, business and social networks, as well as business and social practices, *initiated* by a set of – possibly various types of – actors to achieve a *major overarching goal*.

These radical systemic changes are complemented by radical innovations “below” the system level, as well as millions of incremental changes at all levels.

Whether the intended overall goal has been accomplished is not part of the definition.

### OVERVIEW

Analytical approach and methods

Illustrative cases

Tentative conclusions

## ANALYTICAL APPROACH AND METHODS



### CONCEPTUAL FRAMEWORK

Innovation can be a driving force of change or a possible response to current or expected future societal challenges

In the former case, normative orientations are needed to guide and frame the innovation-driven change process (OECD 2024)

e.g., early regulatory experimentation related to emerging technologies

In the latter, innovation is conducted to deliver novel solutions to help address major societal challenges of other origins, e.g., “missions”

Intended and unintended change processes: it is essential to

- anticipate possible sources and consequences of change
- consider normative issues and dilemmas

This is a demanding strategy-setting process ⇒ innovation systems thinking and foresight are needed

### INNOVATION SYSTEMS THINKING

We need a thorough understanding of the dynamics of change processes:

- how system level changes are set in motion (by what actors and factors, through what mechanisms);
- 'below' the systemic level, what actors can develop and introduce business, social, and hybrid innovations to tackle the above challenges and create new opportunities;
- how these various types of innovations are diffused;
- how knowledge necessary for these innovations is created, utilised, and diffused in an innovation ecosystem and generalised across innovation ecosystems;
- how various other resources are produced and exchanged;
- how the interactions (especially co-operation and competition) among the actors are guided by institutions ('the rules of the game');
- how institutions are crystallised and then change;
- how new innovation ecosystems and new 'nodes' of innovation systems emerge;
- how the innovation policy governance sub-system works and changes;
- how entire innovation systems evolve, get stabilised and then transformed

### FORESIGHT AND OTHER FORWARD-LOOKING ACTIVITIES

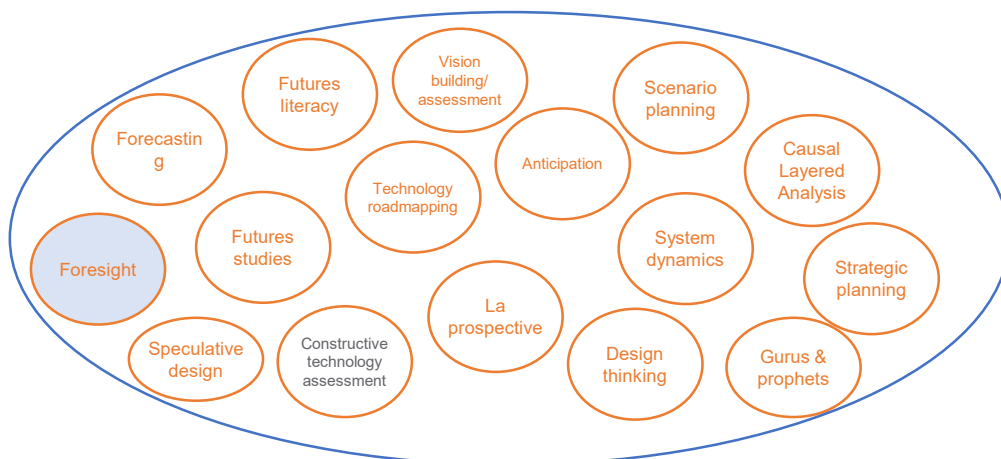

All concerned with the future ⇒ future-oriented or forward-looking activities

Different objectives and communities of practice ⇒ different points of departure into (the) future(s)

## FORESIGHT

Foresight is a “(...) systematic, participatory process, collecting future intelligence and building medium-to-long-term visions, aimed at influencing present-day decisions and mobilising joint actions” (EC HLEG 2002)

It considers multiple futures

A governance tool (conducted to underpin decisions)

Not an academic exercise, not a discipline

Transparent

Creates “ownership” ⇒ Reduces uncertainty

## GOTC: MAIN ACTIVITIES

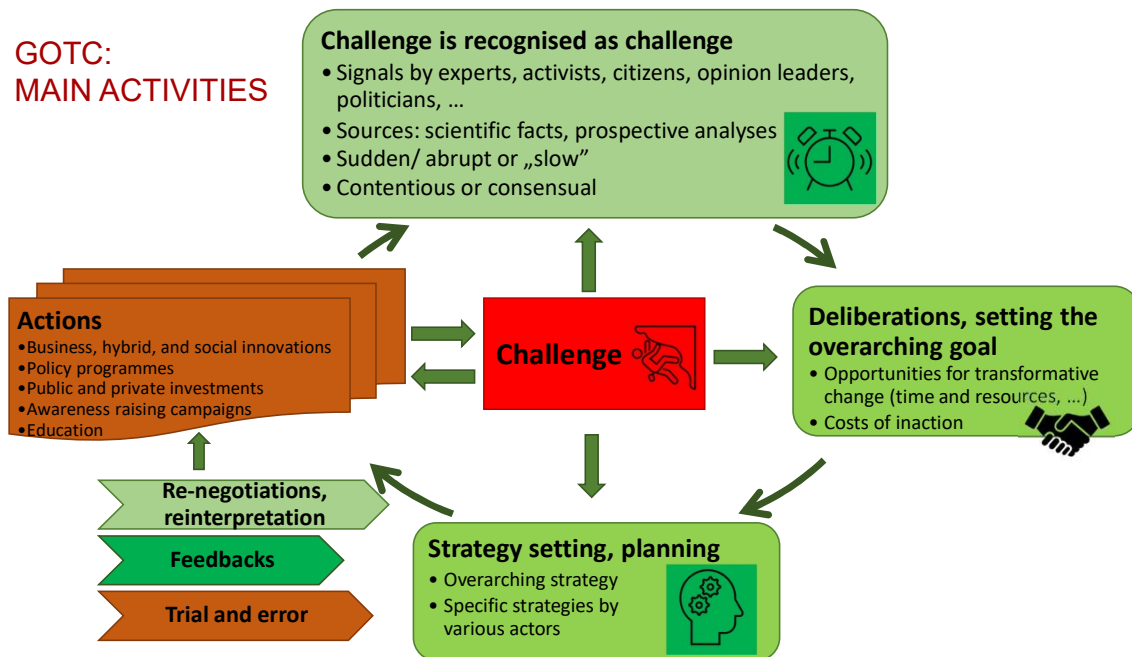

### MAIN ASSUMPTION AND RESEARCH QUESTIONS

In the GOTC context, foresight needs to be applied in a connected manner both at the level of (business, social, and hybrid) innovation processes and at the level of societal transformations at different system levels (from global to local)

At what stages of GOTCs can (should) foresight (and other FLAs) play a role (and what roles)?

What types of (extant, known) foresight (and other FLAs) are relevant at what stages of GOTCs (for what roles)?

Do we need to devise (pilot) new types of foresight (and other FLAs) or combine extant types of foresight (and other FLAs) in a novel way?

Σ Our main objectives:

- offer new building blocks for an integrative conceptual framework to devise and implement GOTCs (cf. Havas et al. 2023)
- initiate a dialogue on the role(s) of foresight (and other FLAs) in GOTCs and the need for new types of foresight (and other FLAs)

### THE RELEVANCE OF FORESIGHT TO GUIDE GOTC

Expected impacts/ benefits

- Process benefits
  - new networks created
  - existing networks strengthened
  - shared vision(s)
- More effective policies
- Uncertainty reduced
- Joint/ orchestrated actions (for the desired GOTC)
- Transformed systems (incl. governance sub-systems)
- Strengthened/ adapted (sub-)systems when transformation is not needed or not possible (for the time being)

## OUR APPROACH

Systematic 'speculation' about the need for and the main features of

- new type of foresight processes to inform and guide GOTC
- nested policies aimed at steering transformative change processes towards normative, jointly set goals

We have identified

- key features of extant foresight (and other FLAs) in light of GOTCs
- real-life cases as starting points to pilot with new types of foresight (and other FLAs) to contribute to GOTCs (at various stages, in different roles)

KEY FEATURES OF  
MULTI-LEVEL,  
AMBIDEXTROUS  
FORESIGHT

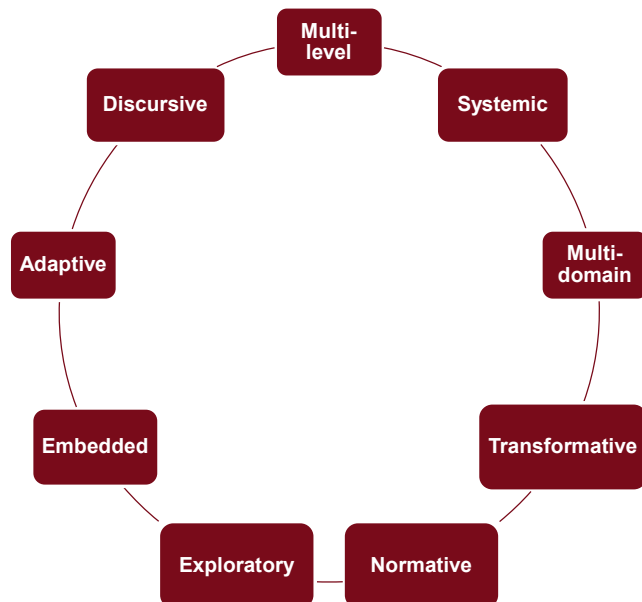

DO WE FIND THESE FEATURES TOGETHER IN EXTANT PROCESSES?

Illustrative cases



FOD: FORESIGHT TOWARDS THE 2<sup>ND</sup> STRATEGIC PLAN OF HORIZON EU

Focus on potentially disruptive social, geopolitical and technological developments

Purpose: "Informing" and "future-proofing" of the proposal for 2<sup>nd</sup> Strategic Plan



### FOD: FORESIGHT TOWARDS THE 2<sup>ND</sup> STRATEGIC PLAN OF HEU

<b>Multi-level</b>	Explicit multi-level context scenarios (global/ EU)
<b>Systemic</b>	Systems thinking underpinning scenario development, combining technological, social and institutional change at multiple levels
<b>Multi-domain</b>	Nine domains addressed in parallel, with some interactions and exchange between them
<b>Transformative</b>	Focus on disruptive developments and their (transformative) consequences
<b>Normative</b>	Major normative issues addressed in some domains (GAI, human enhancement, global commons, climate change/ geoengineering), but no clear normative guidance
<b>Exploratory</b>	Exploratory scenarios developed in most domains
<b>Embedded</b>	Close and regular interaction with the EC Services policy implications: thematic priorities, instruments, and governance
<b>Adaptive</b>	Tailored to a specific client organisation's position (i.e., EC), but no time for re-adjustment
<b>Discursive</b>	Futures4europe online platform for wider stakeholder involvement, online workshops, policy dialogues

### JAPAN'S STRATEGIC INNOVATION PROGRAMME: AUTONOMOUS DRIVING

- ADUS: Autonomous Driving for Universal Services
- Part of national Strategic Innovation Programme
- Multi-Stakeholder Roadmapping
- Multi-site pilot implementation

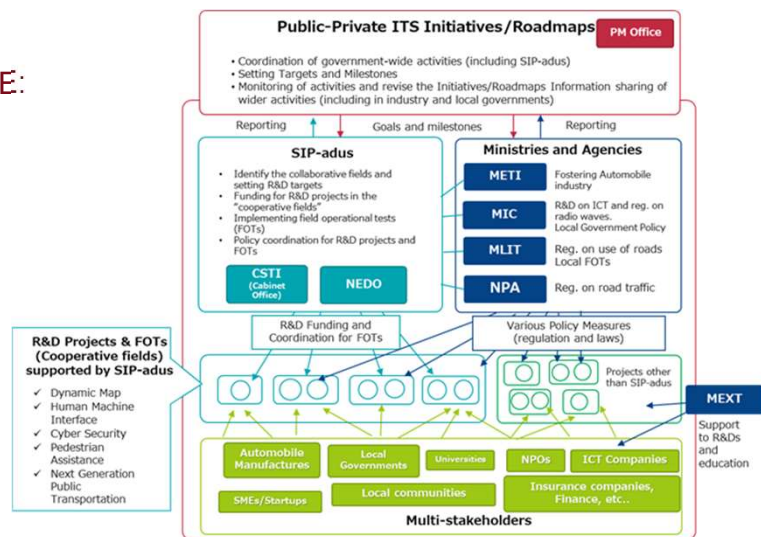

NEDO=New Energy and Industrial Technology Development Organization  
 METI=Ministry of Economy, Trade and Industry  
 MIC=Ministry of Internal Affairs and Communications  
 MLIT=Ministry of Land, Infrastructure, Transport and Tourism  
 NPA=National Police Agency  
 MEXT=Ministry of Education, Culture, Sports, Science and Technology

Based on: Oyamada & Arimoto 2025

18

**JAPAN'S STRATEGIC INNOVATION PROGRAMME: AUTONOMOUS DRIVING**

<b>Multi-level</b>	National vision and roadmap, but regional implementation
<b>Systemic</b>	Integrated systemic perspective on regional pilots; social, behavioural, technological, institutional, organisational innovations
<b>Multi-domain</b>	National SIP programme covers several areas, but largely independent from each other
<b>Transformative</b>	ADUS aims at place-based pilot implementation, based on roadmapping
<b>Normative</b>	Regional implementation offers space for normative deliberation
<b>Exploratory</b>	Largely technology-driven national programme exploring alternative options
<b>Embedded</b>	National programme closely tied to national policy strategy, involving several ministries
<b>Adaptive</b>	Several iterative loops of adapting plans
<b>Discursive</b>	Discursive spaces at regional level, while at national level government-industry fora dominate

TENTATIVE CONCLUSIONS



### SUCCESS FACTORS OF FORESIGHT

An appropriate governance sub-system

Committed client/s

Sound and flexible project plan

Devoted participants

Relevant methodological support and skills development

Professional facilitation and implementation

### DRAWBACKS OF FORESIGHT

Time-consuming

Costly

Demanding and complex ⇒ many factors and actors can 'fail' it

### FORESIGHT AND OTHER TYPES OF FLA

Foresight at the systemic level

Foresight at organisational levels

Foresight on 'components' of GOTC

by public bodies in various policy domains, civil society organisations, businesses

Other types of FLAs can be useful, given the drawbacks of foresight

e.g., expert-based FLAs: faster, cheaper, and easier to align with the clients' needs

**BUT** i) cannot replace foresight; would be against the 'spirit' of GOTC in democratic societies

ii) do not expect process benefits

### TENTATIVE GOVERNANCE, POLICY, AND OTHER PRACTICAL IMPLICATIONS

Orchestrate the above foresight processes and FLAs

Create communication channels across levels (global, international, national, regional, and sectoral) and domains (interrelated issues)

Establish interconnected fora for dialogues among stakeholders

Develop new, 'frugal' methods to run foresight processes; not at the expense of process benefits

Devise methods for monitoring GOTC and for real-time and ex post evaluation [what is ex post in the GOTC context?]

Devote resources to translate foresight implications into actionable recommendations

Be ambitious but remain practical

## DIRECTIONS FOR FUTURE RESEARCH

### Identifying and analysing more cases

EU Mission Boards, other EU level strategy-setting processes, national mission policies, foresight in Estonia, Finland, Germany, Korea, Singapore, ...

### Comparing these cases

Devising modules and 2–3 ideal type process models for multi-level, ambidextrous foresight (for different contexts)

Compiling evaluation criteria for multi-level, ambidextrous foresight

Enriching and refining policy and other practical implications



## THANK YOU!

Attila Havas, K. Matthias Weber

[attila.havas@krtk.hu](mailto:attila.havas@krtk.hu)

[matthias.weber@ait.ac.at](mailto:matthias.weber@ait.ac.at)

Financial support from the Eye of Europe project (Horizon Europe, Grant Agreement ID: 101131738) is gratefully acknowledged.



## DEVELOPMENT OF HIGH-RESOLUTION PM MEASUREMENT NETWORK IN MISKOLC AND KAPOSVÁR, HUNGARY

Zsolt DOBÓ, PhD  
Senior Researcher  
University of Miskolc  
Faculty of Materials and Chemical Engineering  
Institute of Energy, Ceramics, and Polymer Technology



2025. 08. 27.

### HIGH RESOLUTION PM MONITORING NETWORK - MISKOLC

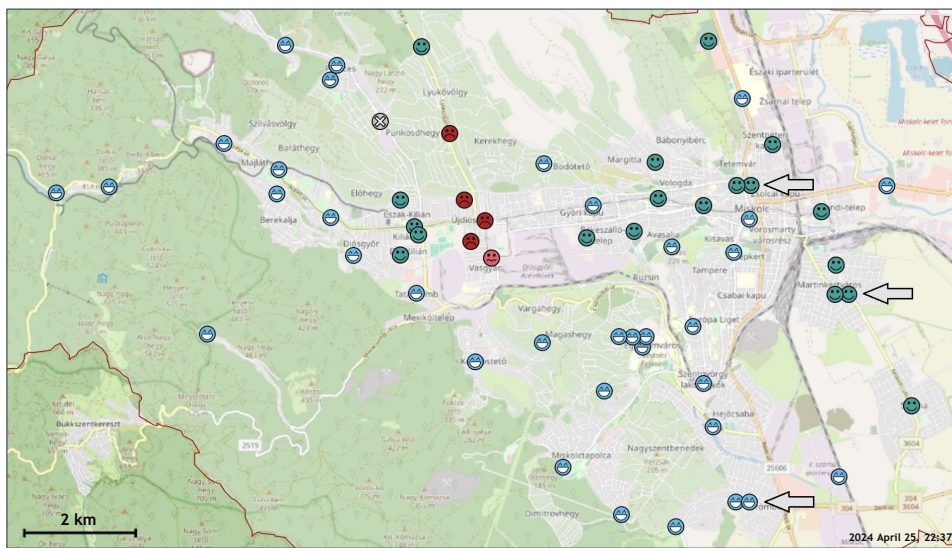

### HIGH RESOLUTION PM MONITORING NETWORK - MISKOLC

pmmonitoring.hu

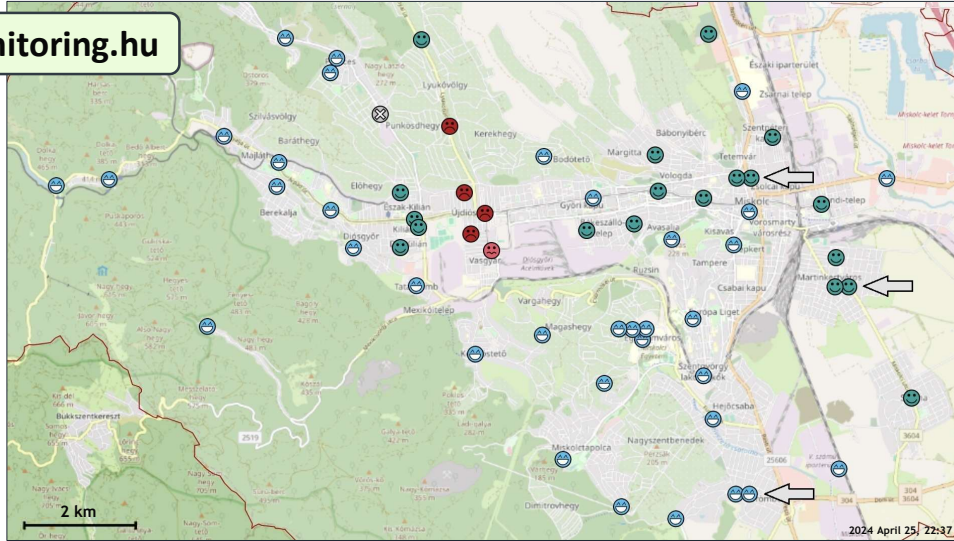

3

### HIGH RESOLUTION PM MONITORING NETWORK - KAPOSVÁR

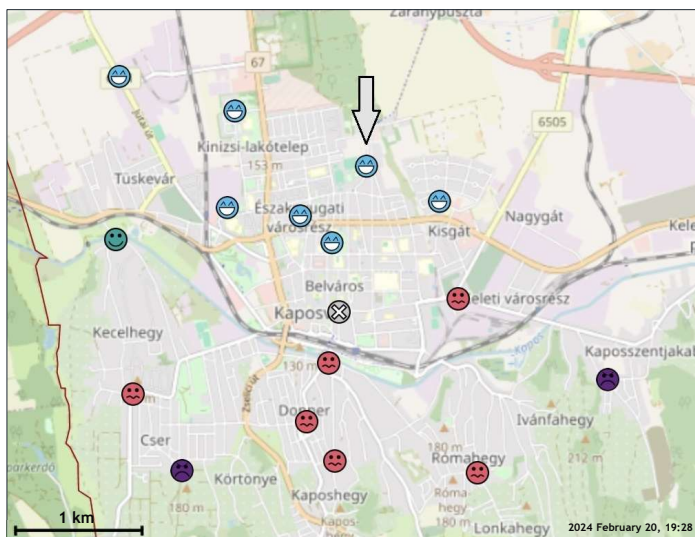

Icon	Air quality	PM <sub>10</sub>	PM <sub>2.5</sub>	µg/m <sup>3</sup>
😊	Excellent	0-25	0-10	
😄	Good	25-40	10-20	
😐	Moderate	40-50	20-25	
😞	Unhealthy	50-75	25-50	
😡	Very unhealthy	75-150	50-75	
😱	Hazardous	150+	75+	



4

## HIGH RESOLUTION PM MONITORING NETWORK - KAPOSVÁR

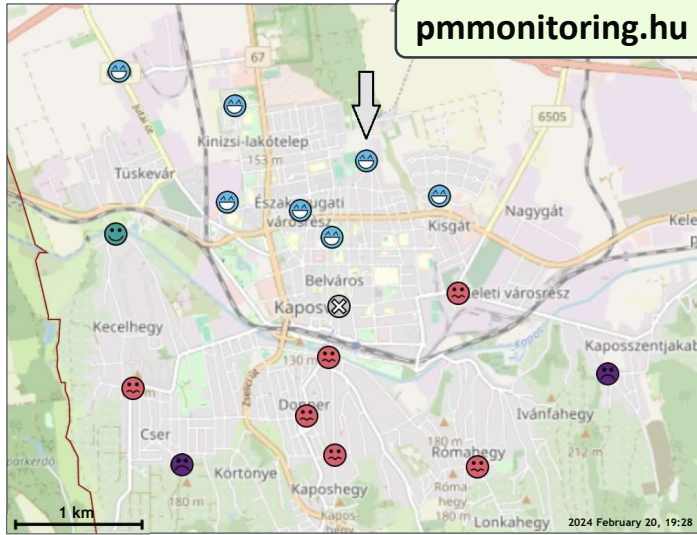

Icon	Air quality	PM <sub>10</sub>	PM <sub>2.5</sub>	µg/m <sup>3</sup>
	Excellent	0-25	0-10	
	Good	25-40	10-20	
	Moderate	40-50	20-25	
	Unhealthy	50-75	25-50	
	Very unhealthy	75-150	50-75	
	Hazardous	150+	75+	



5

## MEASUREMENT DEVICE - PICTURES

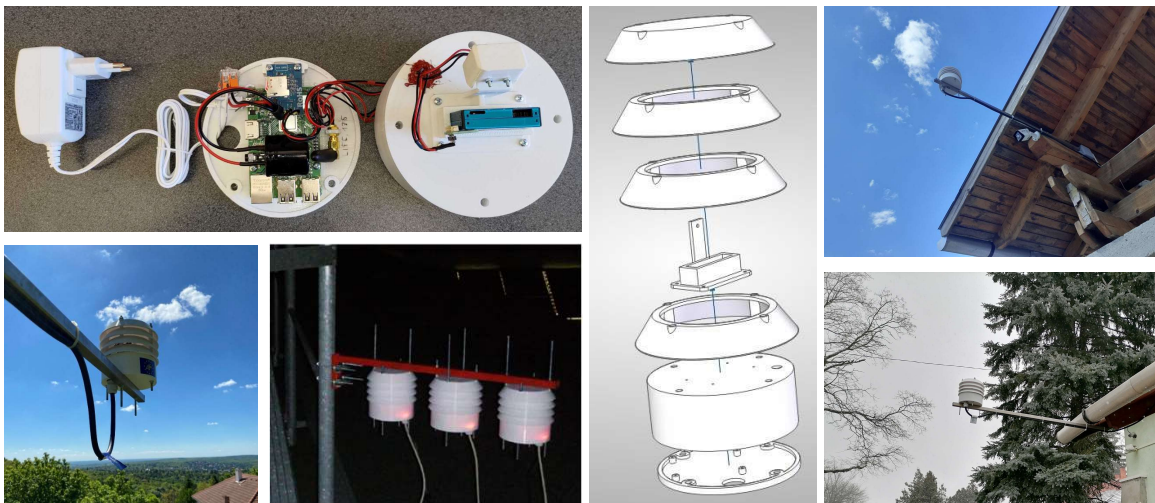

6

MEASUREMENT DEVICE - PICTURES

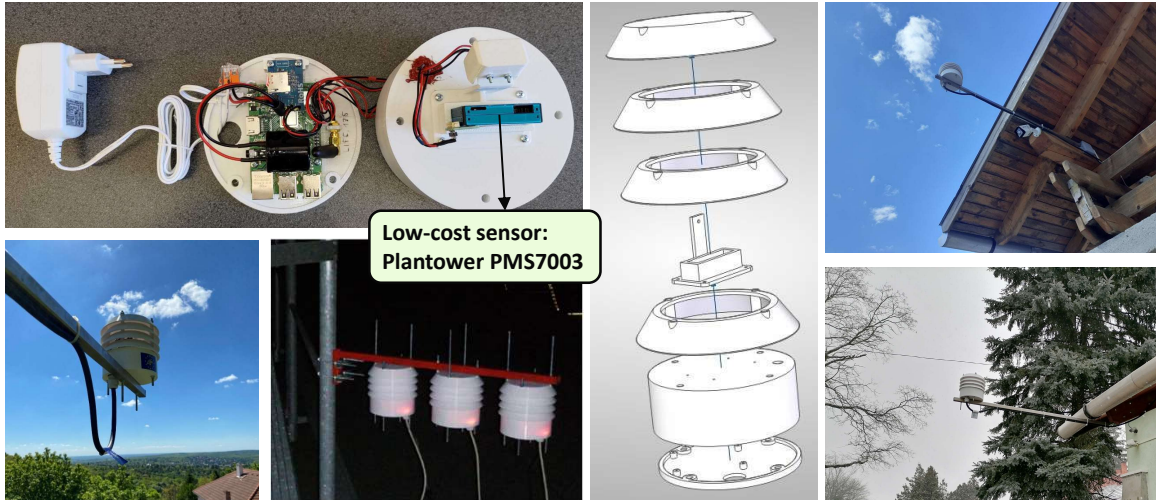

CALIBRATION

- Climate chamber: temperature and relative humidity control
- Reference: TSI DustTrack 8534-M
- Dust source: fuel-rich isobutylene-air flame

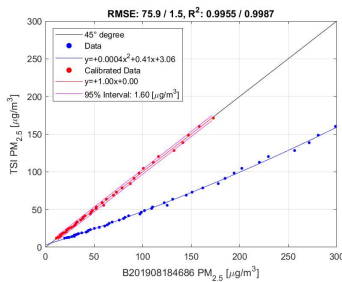
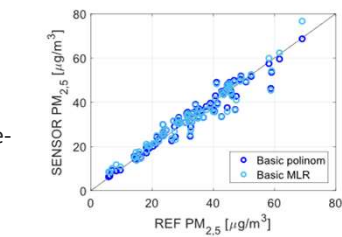
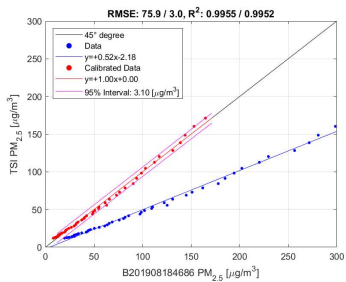

**COMPARISON TO OLM DATA (2023), MISKOLC, BÚZA TÉR, DAILY AV.**

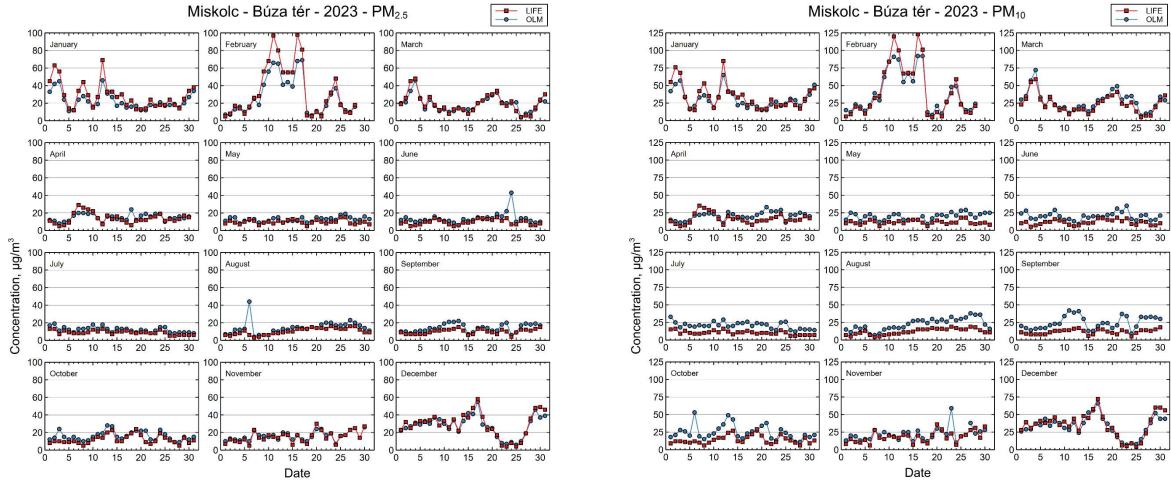

**WHAT CAN WE OBSERVE? WHAT CAN WE LEARN?**

With the help of the measuring network and the installation of a suitable number of measuring units, the following can be observed in extreme detail:

- the level of dust generation,
- the speed and direction of possible spread,
- the degree of dilution,
- the distribution of air pollution in the city,
- the periodicity of air pollution,
- the time necessary for the purification of a smoggy city,
- the formation of hotspots or the behavior of hotspots over time.

# Energy-Water-Food-Climate Nexus

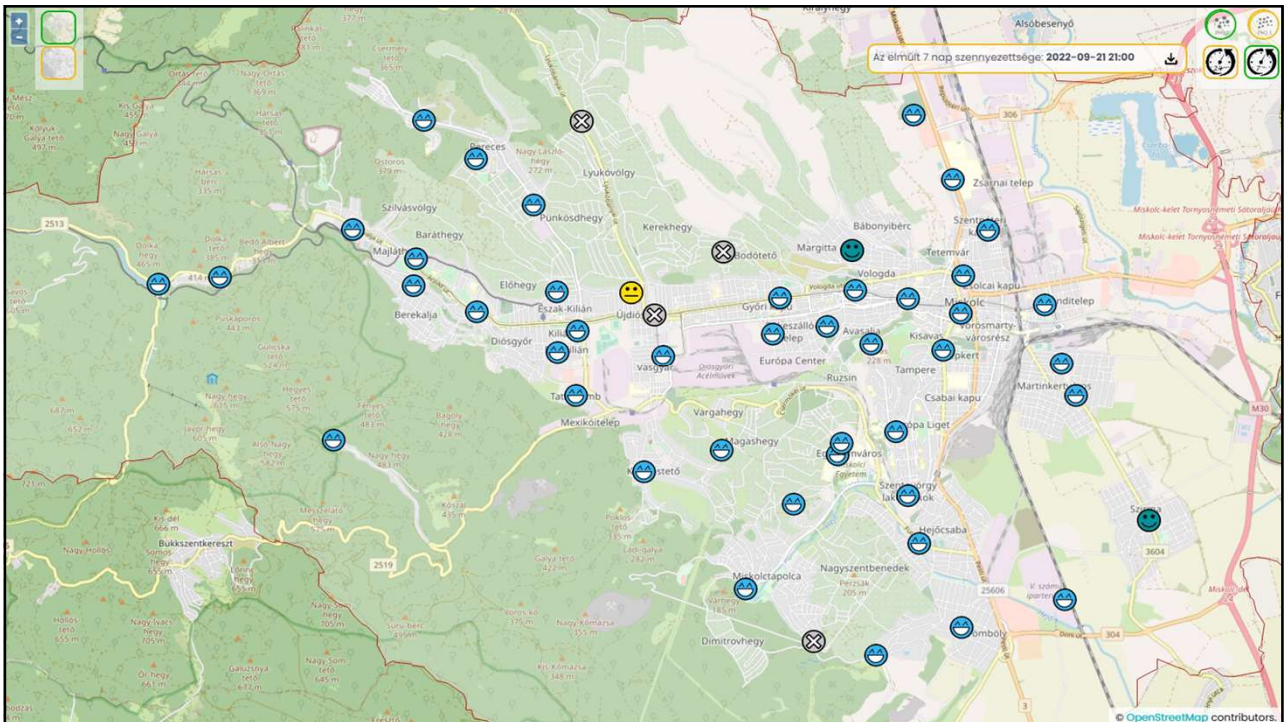
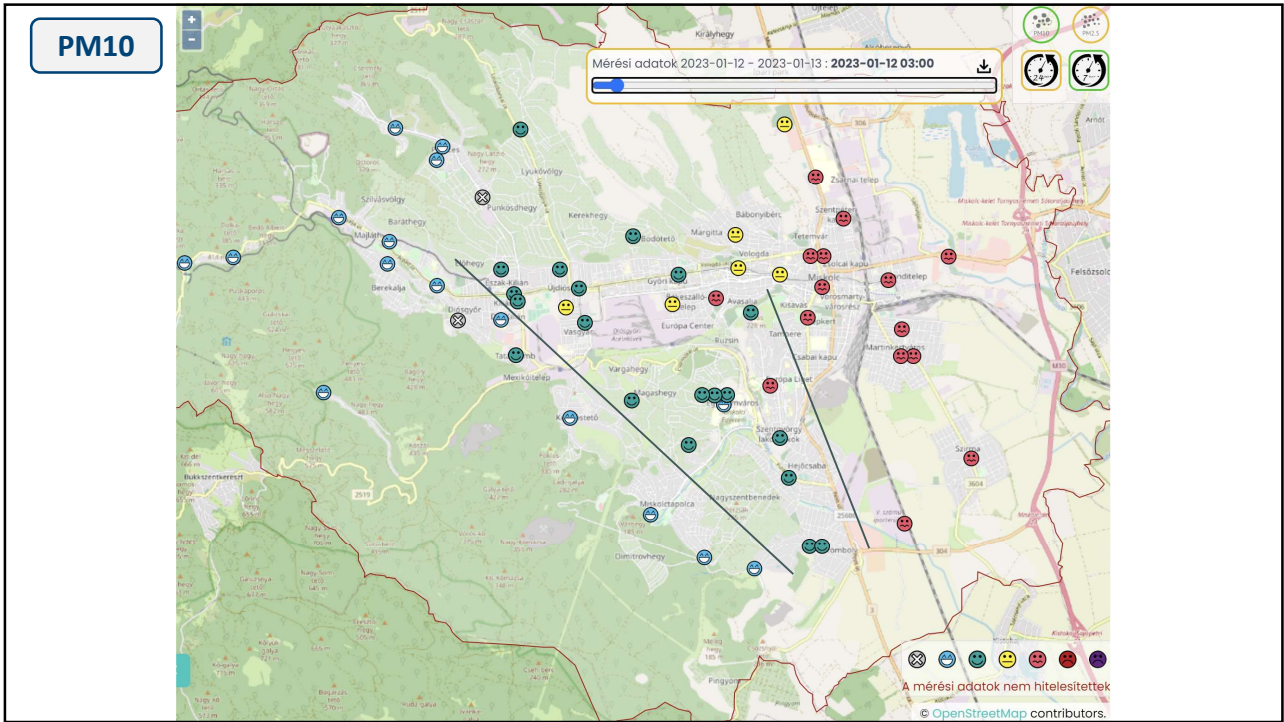

**DATA EVALUATION**

Hours of a day →

N  
↓  
S

	0	1	2	3	4	5	6	7	8	9	10	11	12	13	14	15	16	17	18	19	20	21	22	23
KAP19	24	24	23	23	22	23	25	26	25	26	23	21	21	22	21	22	22	23	24	26	26	27	27	26
KAP8	21	20	20	19	19	19	19	20	21	20	18	16	15	14	14	15	19	23	28	31	30	29	27	23
KAP1	36	32	30	29	30	29	32	34	33	32	28	24	25	24	24	27	32	37	43	48	47	46	44	40
KAP20	17	16	16	16	16	16	17	17	18	18	16	14	13	13	13	14	16	18	20	20	20	19	19	18
KAP9	26	23	21	21	20	22	23	26	28	25	21	18	17	17	18	19	25	29	34	37	37	36	33	29
KAP2	21	20	19	19	19	19	20	22	23	23	20	17	16	16	16	18	24	29	34	34	31	28	26	23
KAP7	27	25	22	22	23	29	35	43	42	33	26	23	21	20	21	25	35	49	58	59	51	45	37	31
KAP15	29	27	24	23	22	22	24	27	28	26	21	18	17	16	17	19	26	37	45	47	45	42	37	34
KAP10	21	20	18	17	17	18	20	23	20	18	15	14	13	12	12	13	16	20	25	27	28	27	26	23
KAP4	19	18	17	17	17	17	17	18	18	17	15	14	13	12	12	13	15	19	21	21	21	21	21	20
KAP13	24	22	21	20	19	19	20	21	22	22	19	17	15	15	15	16	18	21	23	27	29	30	28	26
KAP6	24	22	21	20	20	21	21	23	23	22	19	17	16	15	15	15	17	20	24	27	28	28	27	25
KAP17	18	17	16	16	15	15	16	16	16	15	14	12	11	11	11	11	12	15	17	20	20	20	20	19
KAP16	23	22	21	20	20	19	19	20	20	18	17	14	13	12	12	13	14	16	18	20	22	24	24	24
KAP18	13	12	12	11	11	11	11	11	11	10	9	8	8	7	7	7	7	8	10	12	14	14	14	14
KAP3	20	19	19	19	18	18	18	19	18	17	15	14	13	12	12	12	13	15	17	19	21	22	21	20
KAP11	21	20	19	18	18	18	19	20	19	17	15	14	13	13	13	13	16	19	23	25	25	25	23	22
KAP12	23	22	22	22	22	22	23	24	23	21	20	20	19	19	21	22	25	27	29	29	27	26	24	23

- PM<sub>10</sub> annual average
- Period: 2024
- Location: Kaposvár

**PMMONITORING.HU**

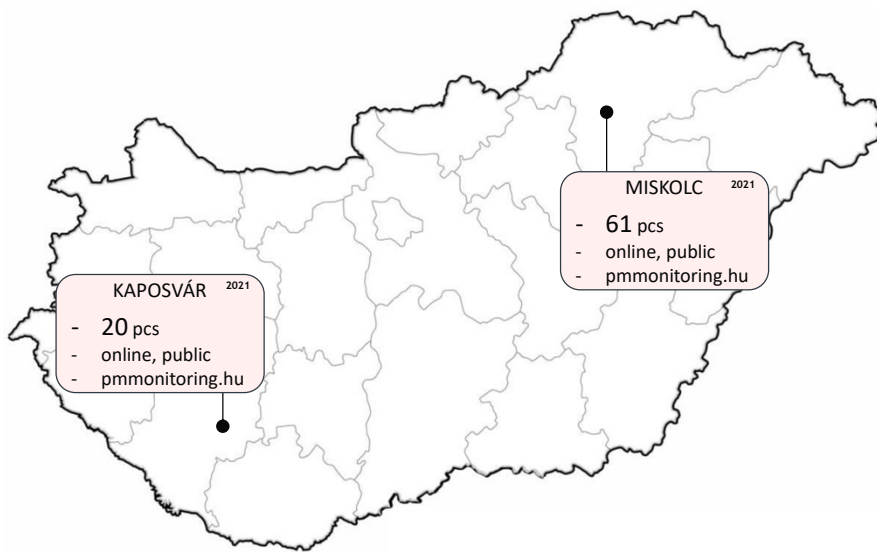

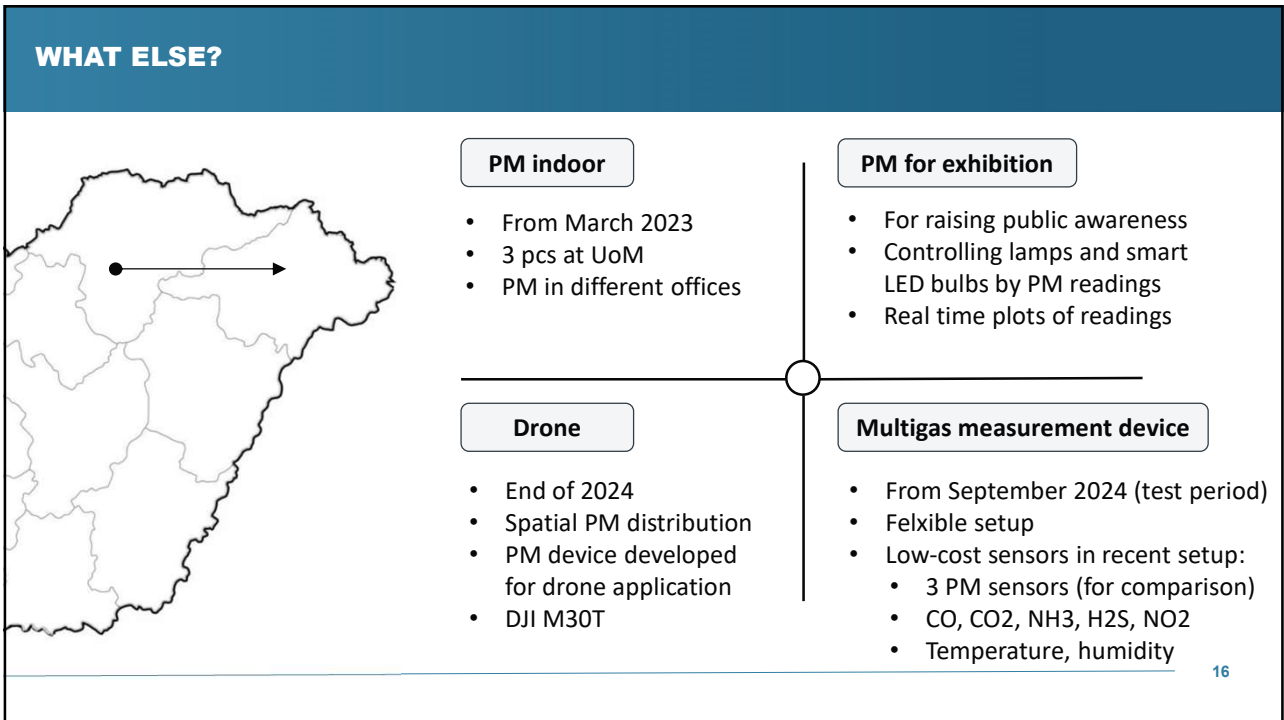
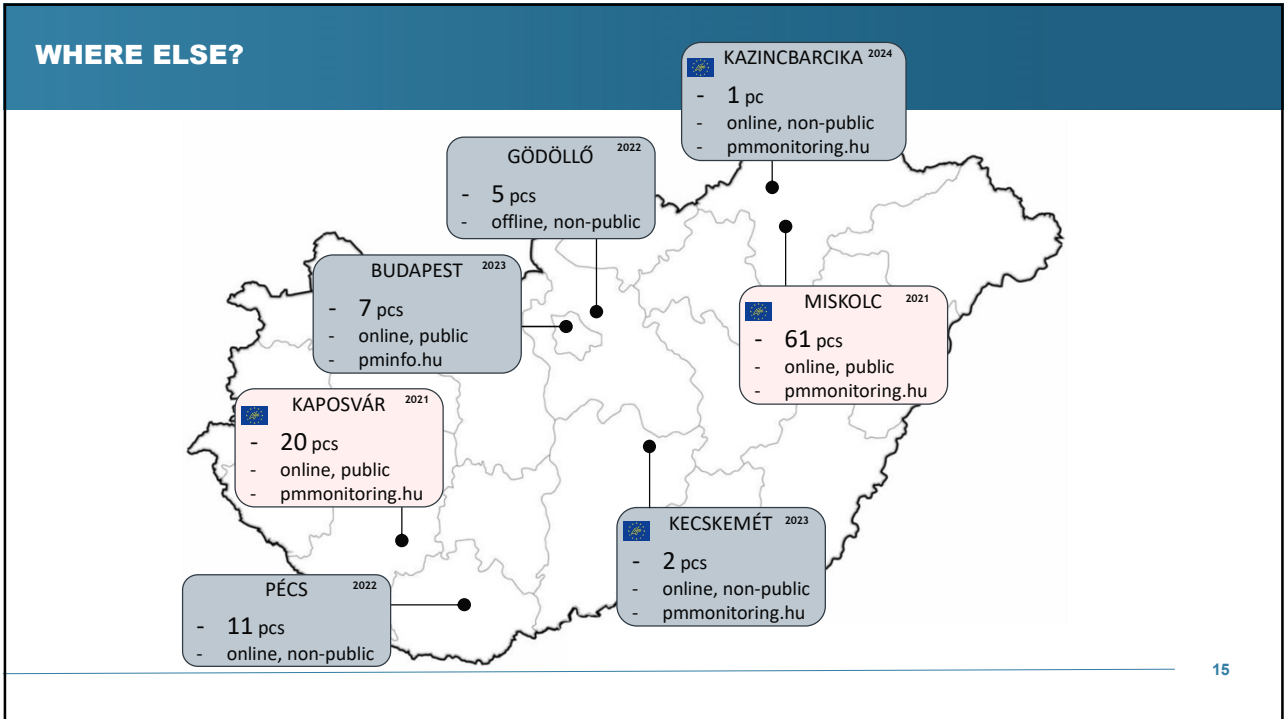

LESSONS LEARNED I

Example 1



Example 2

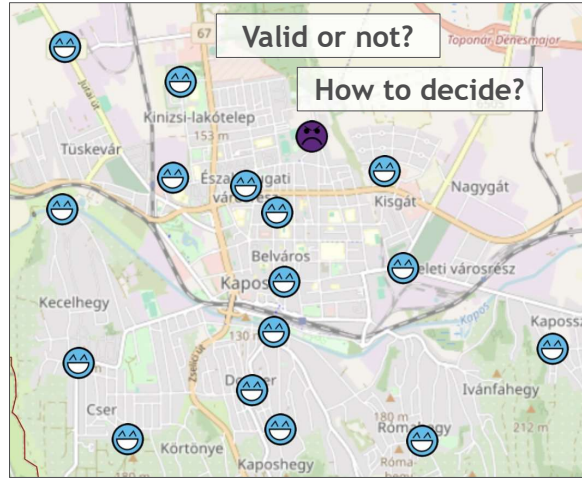

17

LESSONS LEARNED I

Example 1

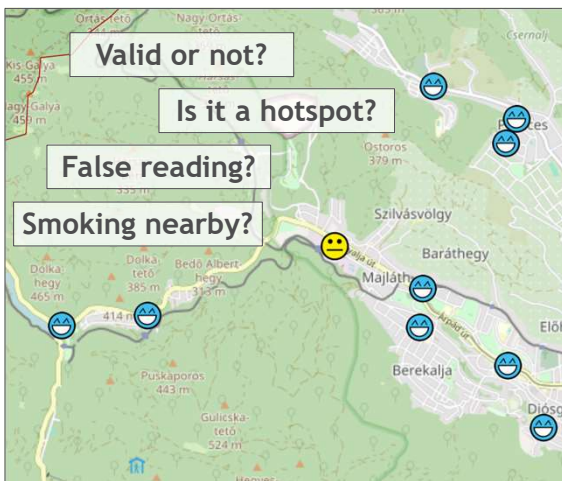

- Sensor duplication
- Sensor triplication
- „Self-inspection”
- ≈10% sensor cost

18

## LESSONS LEARNED II

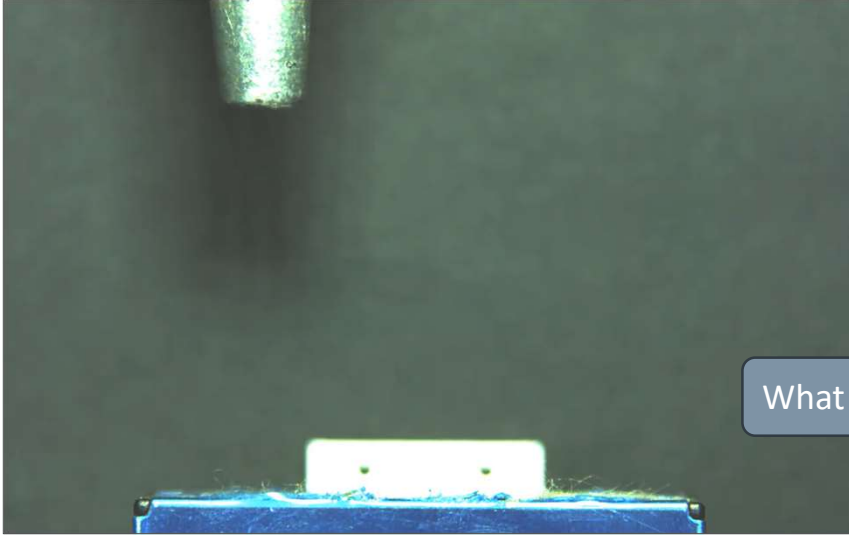

Regular cleaning

What does „regular” mean?

19

## IMPLEMENTATION OF AI

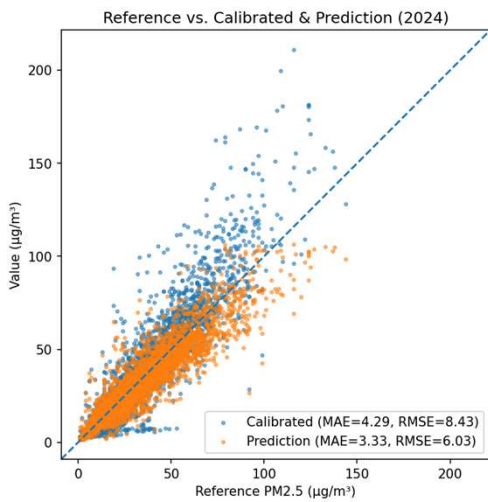

- XGB algorithm
- Training: 2021-2023; Test data: 2024 (8444 hourly data)

	Polynomial regression based on calibration		AI data processing	
	Data points, pcs	Data points, %	Data points, pcs	Data points, %
Total match, hourly average	6172	73,09	6626	78,47
Total match, daily average	280	79,32	308	87,25

20

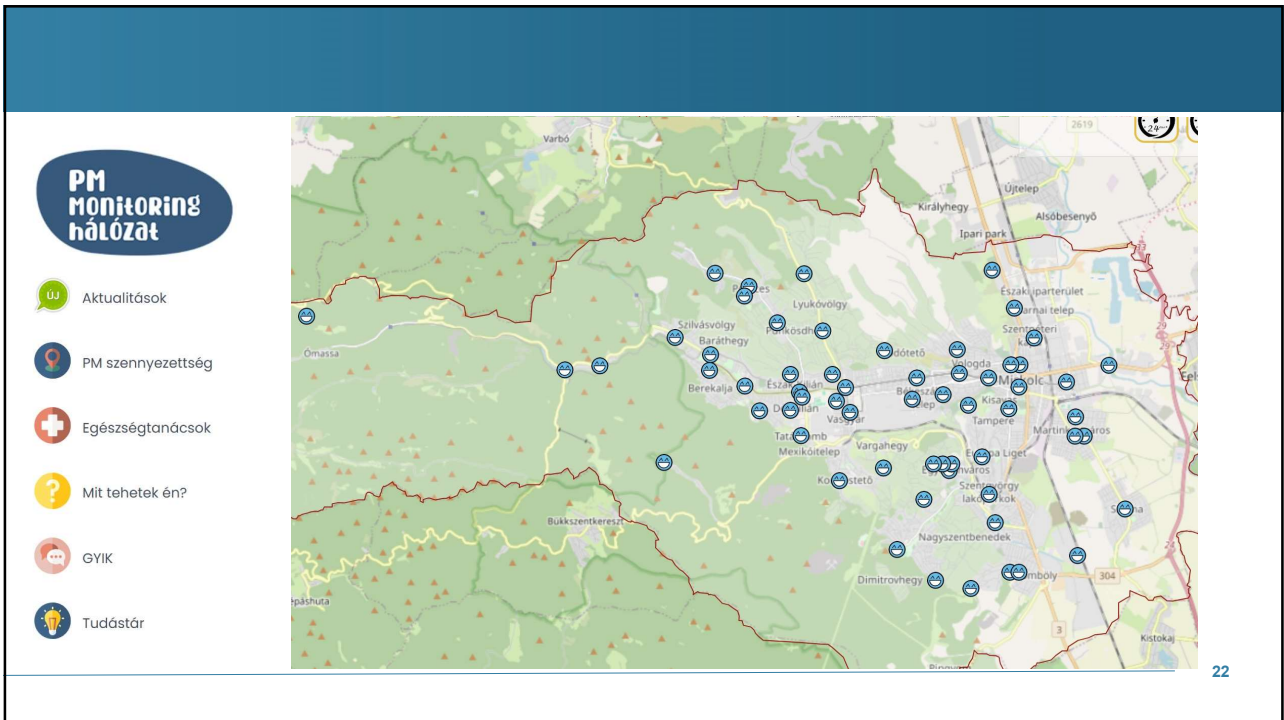
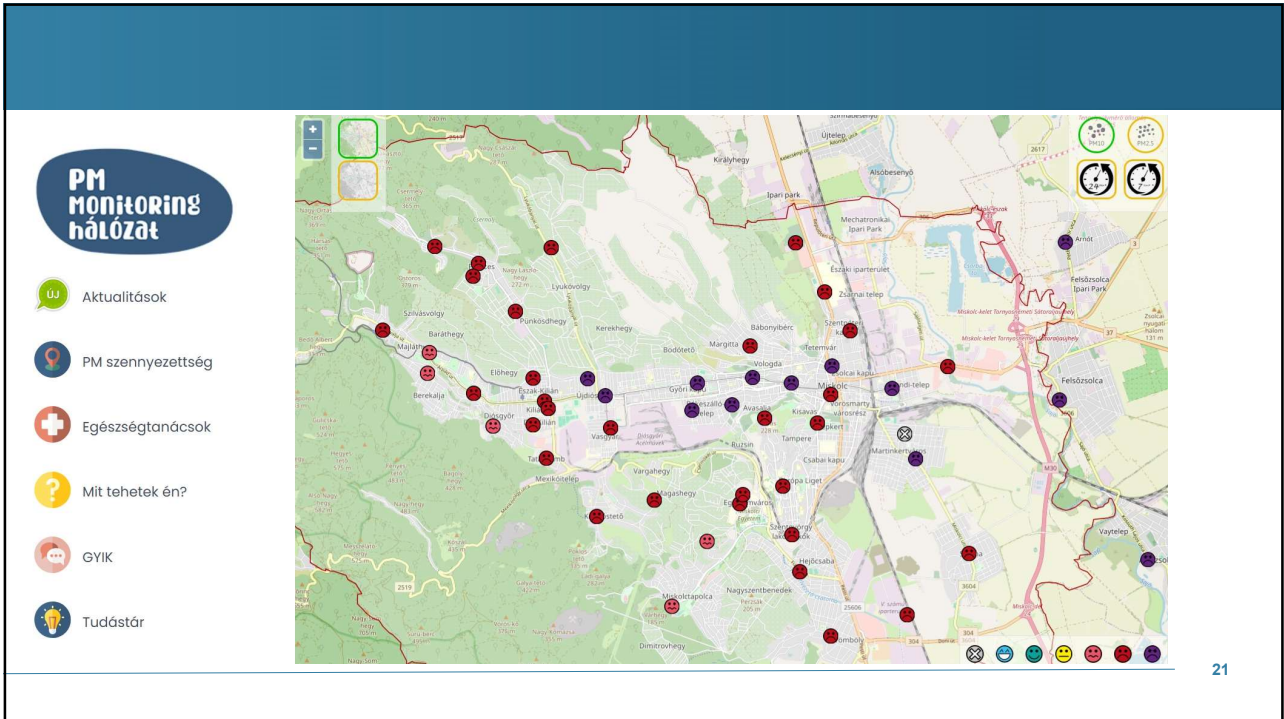



Thank you for your attention!



Zsolt Dobó, PhD  
University of Miskolc  
Faculty of Materials and Chemical Engineering  
Institute of Energy, Ceramics and Polymer Technology



[www.uni-miskolc.hu](http://www.uni-miskolc.hu)



[zsolt.dobo@uni-miskolc.hu](mailto:zsolt.dobo@uni-miskolc.hu)



+36 70 335 0969

A LIFE IP HUNGAIRY (LIFE17 IPE/HU/000017) PROJEKT AZ EURÓPAI UNIÓ LIFE PROGRAMJÁNAK TÁMOGATÁSÁVAL VALÓSUL MEG.

# INNOVATIVE APPROACH IN SEWAGE SLUDGE TREATMENT TOWARDS SOIL SUSTAINABILITY

**Ljudmilla Bokányi** Honorary Professor

and Sándor Nagy; János Takács; Valéria Mádai-  
Üveges ; Ákos Pintér-Móricz

Institute of Raw Materials Preparation and  
Environmental Technology, University of Miskolc;  
Hungary; [ljudmilla.bokanyi@uni-miskolc.hu](mailto:ljudmilla.bokanyi@uni-miskolc.hu)

„The priceless, non-renewable  
SOIL is bleeding from thousand  
wounds”



Soil degradation due to  
compaction, nutrient  
imbalances; acidification  
and salinization,  
altering soil pH and  
chemistry; and  
pollution from  
chemical  
contaminants.

## How to sustain the soil?



## Two pathways

- Mineral fertilizers
- Organic fertilizers to turn the soil into „organic“ one

## Advanced Treatment of Municipal Wastewater

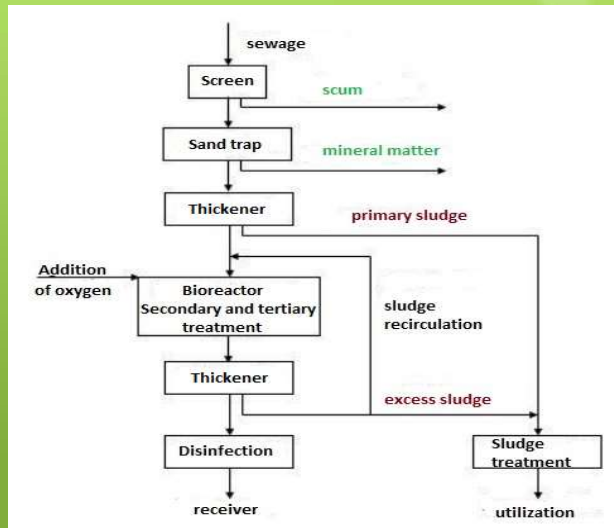

## Sewage Sludge

- High concentration of nutrients
- Significant calorific value
- Its utilisation is required in the spotlight of sustainable development, as well as circular economy

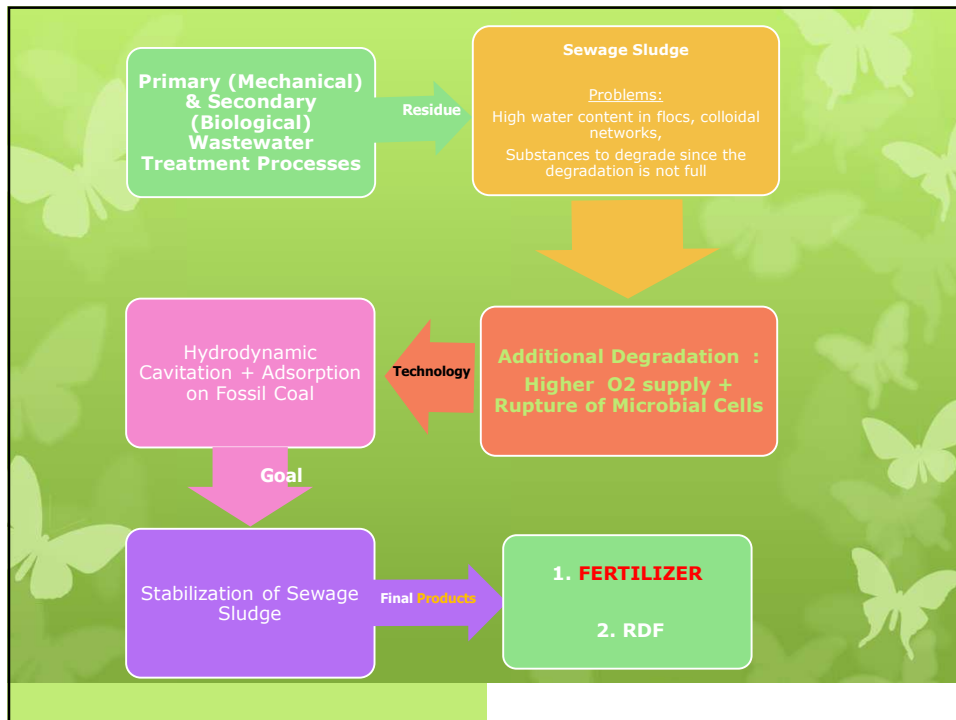

## Cavitation + Adsorption

**Release of oxygen and free radicals due to cavitation;**  
 higher oxygen-gradient; higher secondary aerobic degradation;  
 higher mass transfer.

**Intense hydrodynamic and mechanical effect:**  
 rupture and fragmentation of microbial cells, release of enzymes,  
 fragmentation of macromolecules and aqueous flocs and networks; release of oligomers and monomers;  
 dissolution of oligomers and monomers, higher rate of enzyme-catalytic reactions;  
 adsorption and adhesion phenomena.

## Bakony M. Eocen Lignite

- Oxygen-bearing functional groups: occur in coals as humic acid substances:

Organic macromolecules  
with great complexity

They contain:  
-OH, -COOH, -CHO, and -NH groups

They are known for their very good adsorption  
properties

Forms complexes with plant nutrients and soil  
particles

Prevents their leaching while keeping them  
available for uptake

Makes unabsorbed active substances accumulated  
in the soil over the years absorbable

→Lignite may also be potentially used as a powerful soil additive.

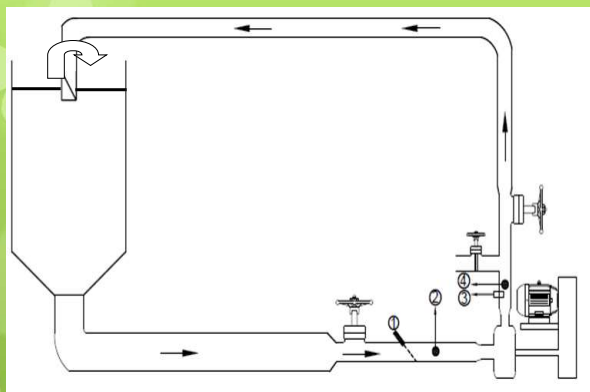

### The scheme of the experimental set-up on cavitation treatment

1- Tank. 2- Valves. 3- Transducers  
and their positioning. 4- Cavitation  
chamber.

### Chemical Oxygen Demand

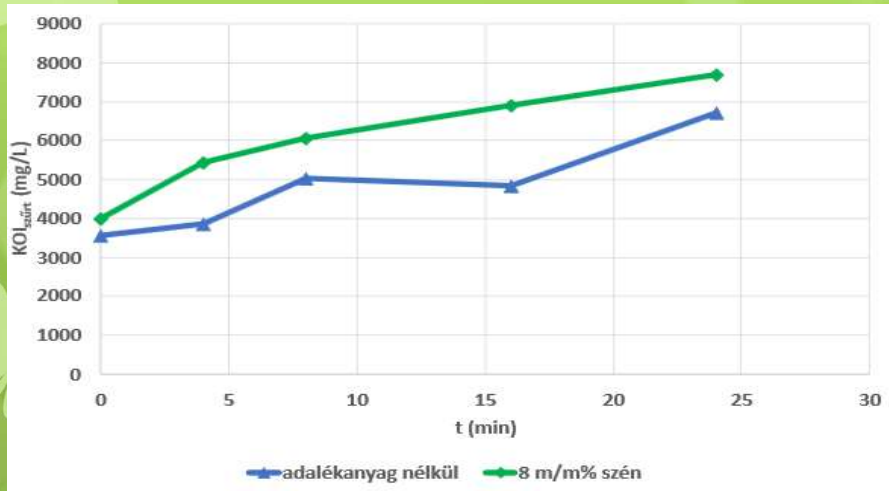

### Biological Oxygen Demand

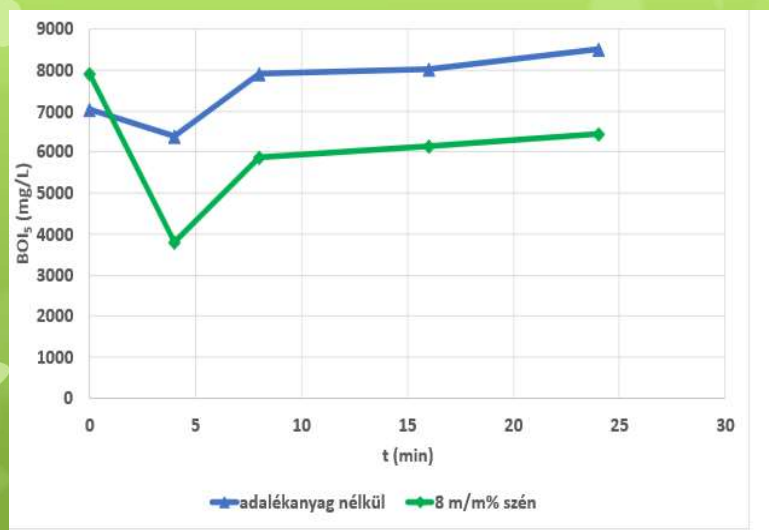

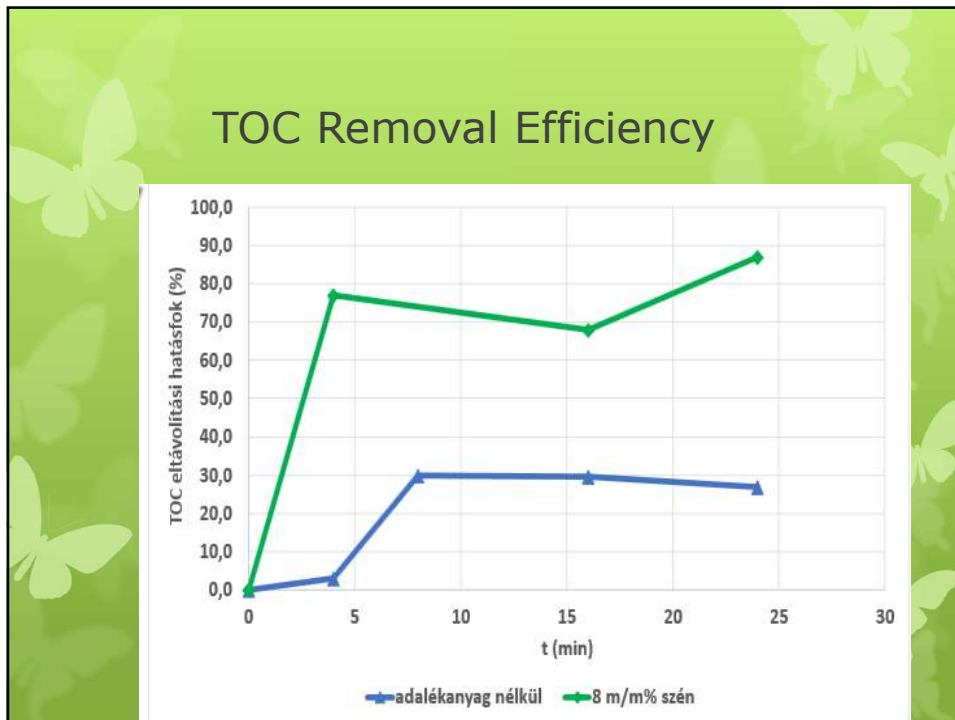

- ### Conclusions
- Bakony Eocene lignite with high humic acid has unique properties.
    - Adsorption affinity and abrasion property of Bakony Eocene lignite can be successfully exploited in the wastewater treatment for the enhancement of the cavitation hydrodynamic treatment of sewage sludge to make it utilisable and of a higher added value.
    - The lignite contributes to the rupture of microbial cells, fragmentation of the macro molecules with the subsequent dissolution and aerobic biodegradation.
    - Outlined by the presented research prospects witnesses the bright future of Bakony Eocene lignite regarding its application in environmental technology.
  -

## Acknowledgements

- The research results were obtained as part of the “Development of bio raw materials products range with a special regard to the local technology – research on the possibility of utilisation by technological optimization” (GINOP-2.2.1-15-2017-00069) with the consortium consisting of Transdanubian Regional Water Works LTD and the Institute of Raw Materials Preparation and Environmental Processing, University of Miskolc.

THANK YOU VERY MUCH FOR YOUR ATTENTION

ENERGY WATER FOOD CLIMATE  
**NEXUS**<sup>®</sup>  
INTERNATIONAL SUMMIT



AUGUST 26-28, 2025  
EUROPE  
MISKOLC, HUNGARY



**MISKOLCI**  
EGYETEM  
UNIVERSITY OF MISKOLC

# Artificial aggregates - an alternative way to substitute primary raw materials for road construction

**Róbert GÉBER**, Bella BÁRDOS-UDVARDI, István KOCSERHA

Miskolc, 27<sup>th</sup> August 2025

## Outline

- Raw materials used in asphalt technology
- Depletion of mineral resources
- Artificial aggregates
- Alkali activation of aluminosilicate materials
- Aim of the research
- Experiments
- Results and discussion

August 27, 2025 Miskolc, Hungary

robert.geber@uni-miskolc.hu

# Raw materials used in asphalt technology

**Asphalt:** a natural or artificially produced material in which mineral aggregates are coated and bound together by a binder (bitumen).

## Primary raw materials used in asphalt pavement:

- crushed stone:  $d > 2.0$  mm
- sand:  $0.063$  mm  $< d < 2.0$  mm
- filler:  $d < 0.063$  mm
- binder: bitumen-based binders

**mineral aggregates  
(angular shape is required!)**



**Natural aggregates:** limestone, andesite, basalt, granite

**The aggregates used in asphalt mixtures are dried and preheated in a drying/mixing drum at a temperature of 180-200 °C before mixing with bitumen.**

August 27, 2025 Miskolc, Hungary

robert.geber@uni-miskolc.hu

# Depletion of mineral resources

- **Globally:** if recycling rates do not increase and regulations are not implemented, **high-quality sand and gravel deposits could be significantly depleted within 20 to 40 years.**
- **Quarries (crushed stone):** quarries have reserves sufficient for **30–50 years**; however, it should be noted that **this varies according to region.**
- **Sustainability risk:** The **demand** for this product **is increasing** due to urban infrastructure development and asphalt production; as a result, the actual **lifespan** of the product **may be shorter than was previously estimated.**
- The preparation process is **energy-intensive** and **generates CO<sub>2</sub> emissions.**

UNEP (2022). *Sand and Sustainability: 10 strategic recommendations to meet a crisis*. GRID-Geneva, United Nations Environment Programme.  
ENSR. *Natural Aggregates Statistics and Information*. U.S. Geological Survey.  
Chalmers University (2024). *A Life Cycle Approach to Environmental Sustainability in Aggregate Production Systems*.

**The potential for a reduction in the quantity of primary mineral raw materials is a matter of significance.**



**Possible solution: artificial aggregates for the substitution of primary aggregates**

August 27, 2025 Miskolc, Hungary

robert.geber@uni-miskolc.hu

# Artificial aggregates



Natural gravel



Expanded perlite



3D printed spherical aggregate



Lightweight clay aggregate (Liapor)

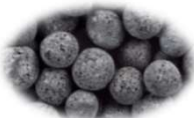

Foam glass aggregate

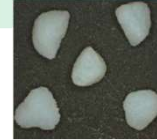

3D printed angular aggregate



Angular aggregate (cold bonding and crushing)

## Production processes (mostly energy-intensive processes):

Granulating/crushing, sieving, heat treatment/additive manufacturing

**Raw materials:** primary raw materials, waste

**Application area:** concrete technology

## Production processes (mostly energy-intensive processes):

cold bonding/autoclave curing/sintering/  
cold reaction sintering/hot isostatic  
pressing/pouring and crushing

**Raw materials:** primary raw materials,  
waste, industrial by-products

August 27, 2025 Miskolc, Hungary

robert.geber@uni-miskolc.hu

# Alkali activation of aluminosilicate materials

- **Alkali activated materials (AAMs)** and **geopolymers (GPs)** can be either made of different primary **aluminosilicate** (*high silica and alumina content*) raw materials or industrial by-products and waste.
- **Geopolymers** ( $\rightarrow$  *low calcium content*) are inorganic polymers formed by the reaction of aluminosilicate materials (**precursors**) with alkaline solutions.
- **Alkali activated materials:** similar binding process, but **different reaction products**  $\rightarrow$  *higher calcium content*.
- They offer an **eco-friendly alternative** to ordinary Portland cement.

August 27, 2025 Miskolc, Hungary

robert.geber@uni-miskolc.hu

## Precursors for alkali activation (examples)



August 27, 2025 Miskolc, Hungary

Rice husk ash

Aluminium dross

robert.geber@uni-miskolc.hu

## Alkali activation of aluminosilicate materials

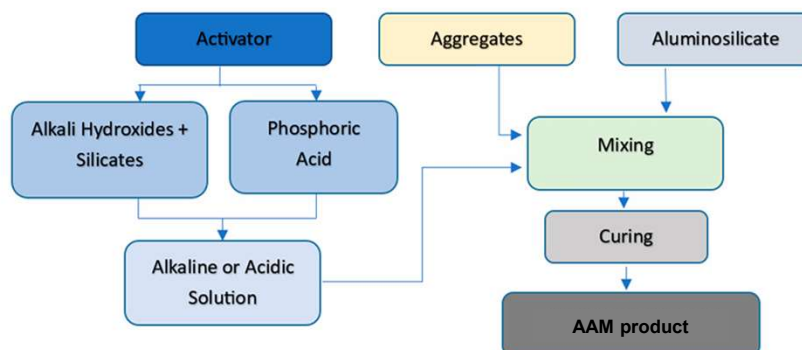

A summary of the alkali activated material (AAM) production process

August 27, 2025 Miskolc, Hungary

robert.geber@uni-miskolc.hu

# Why are alternative solutions needed?

## Unique properties of AAMs and GPs:

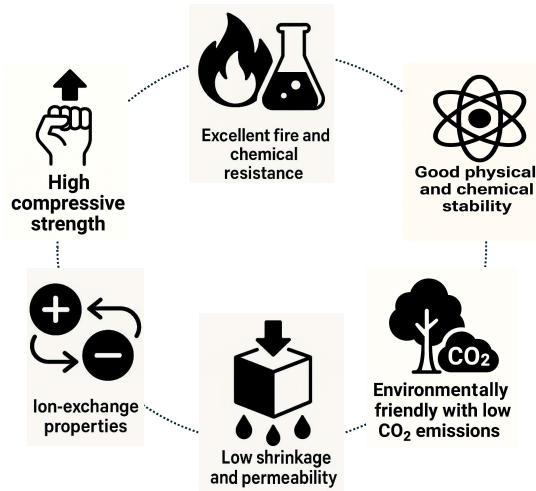

August 27, 2025 Miskolc, Hungary

robert.geber@uni-miskolc.hu

# Why are alternative solutions needed?

## Application of AAMs and GPs:

- Up to 80% **reduction in CO<sub>2</sub> emissions** vs. OPC
- Utilizes **industrial by-products**
- **Lower energy consumption** during production

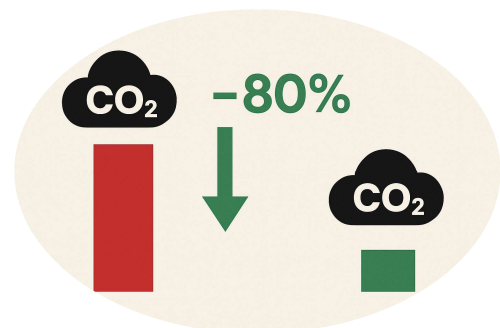

August 27, 2025 Miskolc, Hungary

robert.geber@uni-miskolc.hu

# Aim of the research

- Can we use secondary raw materials to make an artificial aggregate that can replace mineral aggregate in asphalt mixtures, using a process called alkali activation?
- Can alkali-activated material withstand the drying and mixing temperatures used in asphalt technology?
- To what extent should the bitumen be wet on the surface of the alkali-activated material?
- Does bitumen adhere to the surface of the alkali-activated material?

August 27, 2025 Miskolc, Hungary

robert.geber@uni-miskolc.hu

# Experiments

## Precursors for the production of AAMs:



Waste brick powder



Waste concrete powder



Waste roof-tile powder



Aluminium dross



Metakaolin

## Different fractions:

- $d < 0.250$  mm
- $d < 0.106$  mm
- $d < 0.063$  mm

## Median particle size of precursors:

$$d_{50} < 0.025 \text{ mm}$$

August 27, 2025 Miskolc, Hungary

robert.geber@uni-miskolc.hu

# Experiments - trials

Alkali activator solution for the

production of AAMs:

- **NaOH solution** with the molarity of 4 M, 6 M 8 M, 10 M and 12 M
- **Na<sub>2</sub>SiO<sub>3</sub>** (sodium water glass)
- **NaOH:Na<sub>2</sub>SiO<sub>3</sub>:**
  - 85:15
  - 40:60
  - 33.33:66.66
  - 50:50

Solid-to-liquid ratio (precursor : alkali activator solution):

- 60:40
- 70:30

August 27, 2025 Miskolc, Hungary

robert.geber@uni-miskolc.hu

# Experiments - trials

Curing conditions of AAMs:

- Curing temperature:
  - T=20 °C
  - T=40 °C
  - T=60 °C
  - T=80 °C
  - T=90 °C
- Curing time:
  - t=24 h
  - t=48 h
  - t=72 h
  - t=96 h

**A total of 96 different AAM mixtures were prepared.**

**8 samples per mixtures were made.**

August 27, 2025 Miskolc, Hungary

robert.geber@uni-miskolc.hu

# Experiments – results of trials

## Observations:

- **Aluminium dross:** lowest compressive strength ( $R < 4$  MPa) at 28 days age;
- **Waste roof-tile powder:** low compressive strength ( $R < 2$  MPa) at 28 days age;
- **Waste brick powder:** low compressive strength ( $R < 8$  MPa) at 28 days age;  
**Mixing of these precursors also resulted in low compressive strength**
- **Waste concrete powder:** highest compressive strength ( $R \sim 17$  MPa) at 28 days age → **optimization of mixture and conditions to increase the mechanical strength**

August 27, 2025 Miskolc, Hungary

robert.geber@uni-miskolc.hu

# Experiments

## Optimalization:

- **Solid-to-liquid ratio:** 70:30
  - **NaOH:** 10 M
  - **NaOH:Na<sub>2</sub>SiO<sub>3</sub>:** 50:50
  - **Curing temperature:**  $T = 20$  °C
  - **Particle size:**  $d < 0.063$  mm
  - **Additional materials:** supplementary precursors in low amount: metakaolin (calcinated at 750 °C for 3 hours), AeroSil (amorphous silica)
- 
- Compressive strength:**  
59 MPa at 90 days age

August 27, 2025 Miskolc, Hungary

robert.geber@uni-miskolc.hu

# Experiments

## Heat treatment of AAM:

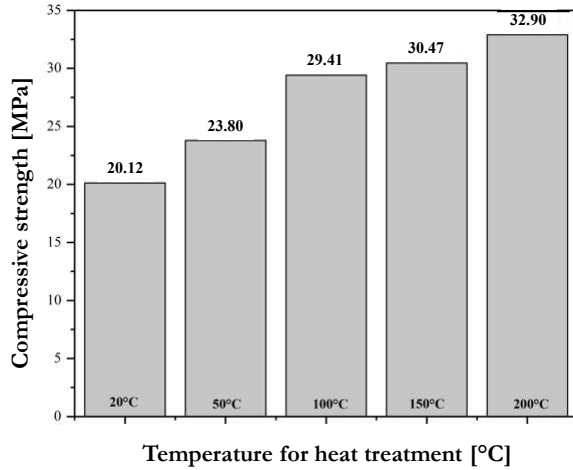

Temperature for heat treatment [°C]	Change in compressive strength compared to the reference sample [%]
20 °C (reference)	-
50 °C	+18.29
100 °C	+46.17
150 °C	+51.44
200 °C	+63.51

**AAM withstand the drying and mixing temperatures used in asphalt technology → no need to used extra energy for heat treatment, as drying/mixing processes are a part of the technology**

August 27, 2025 Miskolc, Hungary

robert.geber@uni-miskolc.hu

# Experiments

## Preparation of artificial aggregates:



Preparation of silicone mould



Artificial aggregate made from AAM

## Bitumen adhesion test:



Aggregates coated with bitumen

Aggregates after adhesion test

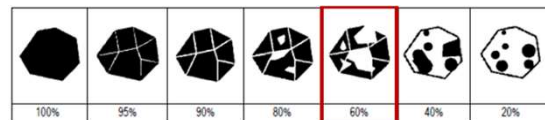

**The result matches the test values for natural stone materials.**

August 27, 2025 Miskolc, Hungary

robert.geber@uni-miskolc.hu

# Experiments

## Bitumen wetting on the surface of AAM:

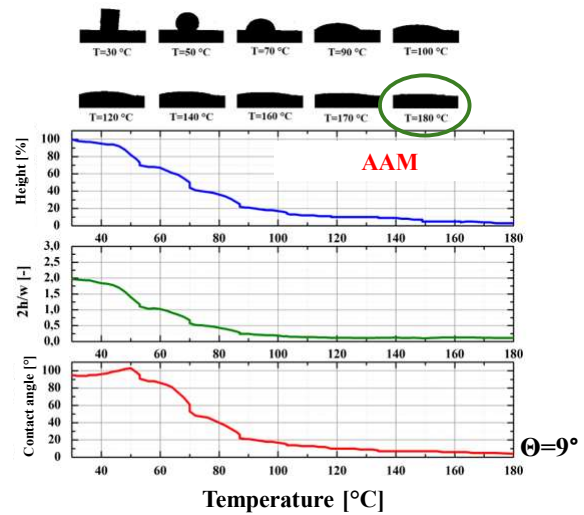
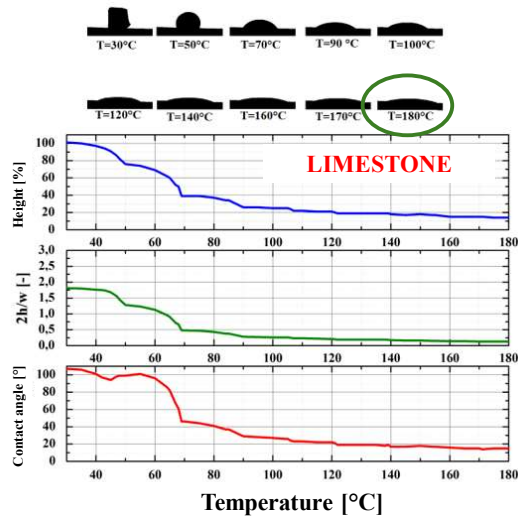

August 27, 2025 Miskolc, Hungary

robert.geber@uni-miskolc.hu

# Conclusions

- Can we use secondary raw materials to make an artificial aggregate that can replace mineral aggregate in asphalt mixtures, using a process called alkali activation?
  - Yes. We produced alkali-activated aggregate with a compressive strength of 59 MPa using casting technology.
- Can alkali-activated material withstand the drying and mixing temperatures used in asphalt technology?
  - Yes. The compressive strength of the artificial aggregate increased as a result of the heat treatment temperature.
- To what extent should the bitumen be wet on the surface of the alkali-activated material?
  - Based on heating microscope tests, the binder wets the surface of the alkali-activated material well.
- Does bitumen adhere to the surface of the alkali-activated material?
  - We determined a bitumen adhesion value of 60% based on the bitumen adhesion test, which confirms that this artificially produced alkali-activated aggregate is suitable for use in asphalt mixtures.

August 27, 2025 Miskolc, Hungary

robert.geber@uni-miskolc.hu

**Thank you for your kind attention!**